

*Nova embalagem*



**MICRO**  
**1000**

Micromil Indústria  
e Comércio LTDA.

# CATÁLOGO AUTOMOTIVO







# MICRO 1000

## ***Nova embalagem para Kits!***

- ✓ ***Kits em skin (vacuum forming)***
- ✓ ***Melhor visualização dos itens***
- ✓ ***Facilita disposição no Display de cartelas***
- ✓ ***Ocupa menos espaço***

**Jogo de juntas continua no saquinho**









## Índice por linha de produtos

|  |    |   |    |
|--|----|---|----|
| 005 JUNTAS CARBURADOR - FIAT.....                  | 1  | 325 JUNTAS INJ.ELETR. - CITROEN (SIMPLES).....      | 57 |
| 010 JUNTAS CARBURADOR - FORD.....                  | 1  | 330 JUNTAS P/ INJ. ELETR. - CITROEN (COMPLETO)..... | 58 |
| 015 JUNTAS CARBURADOR - GM.....                    | 1  | 335 JUNTAS INJ. ELETR. - FIAT (SIMPLES).....        | 58 |
| 020 JUNTAS CARBURADOR - VW.....                    | 2  | 340 JUNTAS P/ INJ. ELETR. - FIAT (COMPLETO).....    | 59 |
| 025 JUNTAS CARBURADOR - ELETRONICO.....            | 3  | 345 JUNTAS INJ. ELETR. - FORD (SIMPLES).....        | 60 |
| 030 JUNTAS AVULSAS CARBURADOR.....                 | 4  | 350 JUNTAS P/ INJ. ELETR. - FORD (COMPLETO).....    | 61 |
| 035 KIT CARBURADOR - FIAT (SIMPLES).....           | 4  | 355 JUNTAS INJ. ELETR. - GM (SIMPLES).....          | 62 |
| 045 KIT CARBURADOR - FIAT (COMPLETO).....          | 5  | 360 JUNTAS P/ INJ. ELETR.- GM (COMPLETO).....       | 63 |
| 050 KIT CARBURADOR - FORD (SIMPLES).....           | 5  | 365 JUNTAS P/ INJ. ELETR. - HONDA (SIMPLES).....    | 64 |
| 060 KIT CARBURADOR - FORD (COMPLETO).....          | 5  | 370 JUNTAS P/ INJ. ELETR. - HONDA (COMPLETO).....   | 64 |
| 065 KIT CARBURADOR - GM (SIMPLES).....             | 6  | 375 JUNTAS INJ. ELETR. - PEUGEOT (SIMPLES).....     | 64 |
| 075 KIT CARBURADOR - GM (COMPLETO).....            | 7  | 380 JUNTAS P/ INJ. ELETR. - PEUGEOT (COMPLETO)..... | 65 |
| 080 KIT CARBURADOR - VW (SIMPLES).....             | 8  | 385 JUNTAS INJ. ELETR - RENAULT (SIMPLES).....      | 65 |
| 090 KIT CARBURADOR - VW (COMPLETO).....            | 9  | 390 JUNTAS P/ INJ. ELETR. - RENAULT (COMPLETO)..... | 66 |
| 095 KIT CARBURADOR ELETR. (SIMPLES).....           | 10 | 395 JUNTAS INJ. ELETR. - VW (SIMPLES).....          | 66 |
| 105 KIT CARB ELETRONICO (COMPLETO).....            | 10 | 400 JUNTAS P/ INJ. ELETR. - VW (COMPLETO).....      | 67 |
| 110 KIT DE GICLEUR SOLEX - FIAT.....               | 10 | 405 JUNTAS INJ. ELETR. - SUZUKI (SIMPLES).....      | 69 |
| 115 KIT DE GICLEUR SOLEX - FORD.....               | 10 | 410 JUNTAS P/ INJ. ELETR. - SUZUKI (COMPLETO).....  | 69 |
| 120 KIT DE GICLEUR SOLEX - GM.....                 | 11 | 415 JUNTAS AVULSAS INJ.ELETR.....                   | 69 |
| 125 KIT DE GICLEUR SOLEX - VW.....                 | 12 | 420 PEÇAS DIVERSAS INJ. ELETR.....                  | 69 |
| 130 KIT DE GICLEUR WEBER - FIAT.....               | 13 | 430 KITS P/ BICO INJETOR.....                       | 70 |
| 135 KIT DE GICLEUR WEBER - FORD.....               | 15 | 432 FILTRO P/ BICO INJETOR.....                     | 72 |
| 140 KIT DE GICLEUR WEBER - GM.....                 | 15 | 433 FILTRO, ANEL E ARRUELA .....                    | 72 |
| 145 KIT DE GICLEUR WEBER - VW.....                 | 15 | 435 COMPONENTES P/ BICO INJETOR.....                | 73 |
| 150 DIAFRAGMA.....                                 | 17 | 440 FILTRO DE COMBUSTIVEL.....                      | 74 |
| 155 PISTÃO.....                                    | 20 | 445 GUARNIÇÕES.....                                 | 75 |
| 160 INJETORES E GICLEURS.....                      | 21 | 450 MANGUEIRAS DIVERSAS.....                        | 77 |
| 165 PARAFUSO MARCHA L.....                         | 25 | 455 JTA TAMP A VALV/CARTER - FIAT (BOR.).....       | 78 |
| 170 VÁLV.BÓIA SOLEX.....                           | 26 | 460 JTA TAMP A VALV/CARTER - FORD (BORR.).....      | 78 |
| 175 VÁLV.BÓIA WEBER.....                           | 27 | 465 JTA TAMP A VALV/CARTER - GM (BORR.).....        | 79 |
| 180 TUBO, GICLEUR ML, RESPIRO E PORTA GICLEUR..... | 28 | 470 JTA TAMP A VALV/CARTER - VW (BORR.).....        | 79 |
| 185 CONEXÃO E TUBO.....                            | 29 | 475 JTA TAMP A VALV/CARTER - IMPORT. (BORR.).....   | 80 |
| 190 PARAFUSO REGULADOR.....                        | 29 | 480 JTA TAMP A VALV/CARTER - FIAT (CORTIÇA).....    | 80 |
| 195 BUCHA PARA EIXO.....                           | 29 | 485 JTA TAMP A VALV/CARTER - FORD (CORTIÇA).....    | 80 |
| 200 PREPARAÇÃO - WEBER 40/44/45.....               | 31 | 490 JTA TAMP A VALV/CARTER - GM (CORTIÇA).....      | 80 |
| 205 TAMP A E CALÇO.....                            | 33 | 495 JTA TAMP A VALV/CARTER - VW (CORTIÇA).....      | 81 |
| 210 CALÇO, FLANGE E TERMINAL.....                  | 33 | 500 COLETORES E ESCAPAMENTOS - ASIA MOTORS.....     | 81 |
| 215 CALÇO P/ CARBURADOR.....                       | 34 | 505 COLETORES E ESCAPAMENTOS - AUDI.....            | 81 |
| 220 PEÇAS DIVERSAS CARBURADOR.....                 | 35 | 510 COLETORES E ESCAPAMENTOS - CITROEN.....         | 81 |
| 225 MOLA.....                                      | 36 | 515 COLETORES E ESCAPAMENTOS - FIAT.....            | 81 |
| 230 BOIA.....                                      | 36 | 520 COLETORES E ESCAPAMENTOS - FORD.....            | 83 |
| 235 CORRETOR DE AR SOLEX (CATE) .....              | 37 | 525 COLETORES E ESCAPAMENTOS - GM.....              | 85 |
| 240 CORRETOR DE AR SOLEX (CARS) .....              | 38 | 530 COLETORES E ESCAPAMENTOS - HONDA.....           | 87 |
| 245 CORRETOR DE AR WEBER (CARC HT) .....           | 39 | 535 COLETORES E ESCAPAMENTOS - HYUNDA Y.....        | 87 |
| 250 CORRETOR DE AR WEBER (RPMP) .....              | 41 | 540 COLETORES E ESCAPAMENTOS - JEEP.....            | 87 |
| 255 GICLEUR PRINCIPAL CHT (GPCHT) .....            | 42 | 545 COLETORES E ESCAPAMENTOS - KIA MOTORS.....      | 88 |
| 260 GICLEUR PRINC WEBER 228 DFV (GPDFV) .....      | 44 | 550 COLETORES E ESCAPAMENTOS - MERCEDES BENZ.....   | 88 |
| 265 GICLEUR PRINCIPAL SOLEX ( GAPR ) .....         | 45 | 560 COLETORES E ESCAPAMENTOS - NISSAN.....          | 88 |
| 270 GICLEUR PRINC SOLEX 35 ALFA 1(GPMS) .....      | 47 | 565 COLETORES E ESCAPAMENTOS - PEUGEOT.....         | 88 |
| 275 GICLEUR PRINC 190/495 TLDZ (GPTLDZ) .....      | 48 | 570 COLETORES E ESCAPAMENTOS - RENAULT.....         | 89 |
| 280 GICLEUR MARCHA LENTA (GMLDFV) .....            | 50 | 580 COLETORES E ESCAPAMENTOS - VW.....              | 89 |
| 285 GICLEUR M LENTA WEBER(GMLTLDZ) FINO .....      | 51 | 585 PEÇAS DIVERSAS MOTORES.....                     | 90 |
| 290 GICLEUR M LENTA WEBER CHT (GPML) .....         | 51 | 590 JUNTAS P/ CAMBIO - FIAT.....                    | 91 |
| 295 GICLEUR M L WEBER MINI PROG (GGML) .....       | 52 | 595 JUNTAS P/ CAMBIO - FORD.....                    | 91 |
| 300 GICLEUR DE M LENTA C/ TUBO 2E/3E .....         | 53 | 600 JUNTAS P/ CAMBIO - GM.....                      | 91 |
| 305 GICLEUR DE M LENTA C/ TUBO BLFA .....          | 55 | 605 JUNTAS P/ CAMBIO - VW.....                      | 91 |
| 310 TUBO MISTURADOR .....                          | 55 | 610 JUNTAS DIVERSAS.....                            | 92 |
| 315 TUBO MISTURADOR BLFA .....                     | 56 | 615 PEÇAS PARA MOTOS.....                           | 92 |
| 320 PORTA GICLEUR .....                            | 57 | 620 TECIDOS E PAPEIS.....                           | 92 |







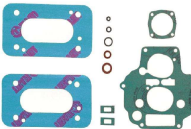
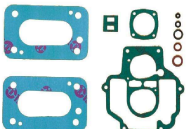
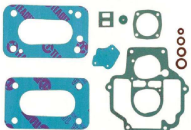
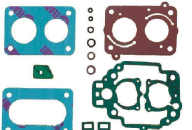
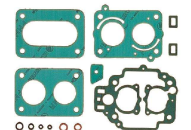
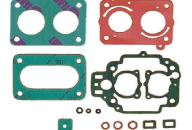



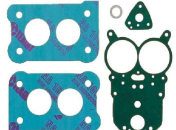

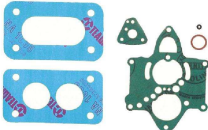
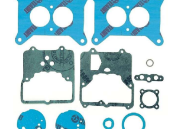
**005 JUNTAS CARBURADOR - FIAT**

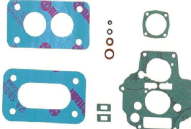
|   |   |   |  |
|---|---|---|--|
| <p><b>100070/1</b></p>  <p>JTAS CARB.FIAT 147-SOLEX SIMPLES 32 DIS</p>                           | <p><b>100070/2</b></p>  <p>JTAS CARB.FIAT 147-SOLEX SIMPLES 32 DIS C/CALÇO</p>     | <p><b>100160/2</b></p>  <p>JTAS CARB.FIAT UNO/PREMIO 1500-SOLEX-35 ALFA 1</p> | <p><b>100190/1</b></p>  <p>JTAS CARB.FIAT 1050/1300-WEBER 190-S/CALÇO</p>                 |
| <p><b>100190/3</b></p>  <p>JTAS CARB.FIAT 1050/1300 -WEBER 190 - C/CALÇO</p>                     | <p><b>100190/5</b></p>  <p>JTAS CARB.FIAT 1050/1300-WEBER-190-C/CALÇO/JT CORB.</p> | <p><b>100460/2</b></p>  <p>JTAS CARB.FIAT UNO/PREMIO 1500-WEBER</p>           | <p><b>100460/4</b></p>  <p>JTAS CARB.FIAT UNO/ELBA 1.6R/UNO MILLE BRIO-WEBER DPL. 460</p> |
| <p><b>100460/5</b></p>  <p>JTAS CARB.FIAT TEMPRA 2.0 8V. - 1992/... GASOL/ALC. - CARB.WEBER</p> | <p><b>100495/2</b></p>  <p>JTAS CARB.UNO/PREM/ELB.90/TLDF 495(M)</p>              | <p><b>100495/3</b></p>  <p>JTAS CARB.UNO/PREM/ELB. 93/TLDF 495 (PH)</p>      | <p><b>100495/5</b></p>  <p>JTAS CARB.UNO/PREM/ELBA 93/...WEBER TLDF 495 /IGN.MAP.</p>    |



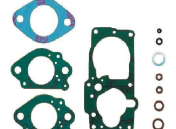







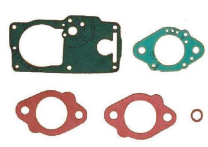
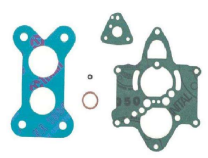
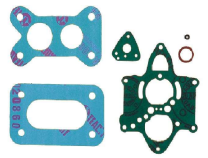



**010 JUNTAS CARBURADOR - FORD**

|   |   |   |  |
|---|---|---|--|
| <p><b>100050/2</b></p>  <p>JTAS CARB.CORCEL/BEL/PAMPA 78/...-SOLEX DPL 34 SEIE</p> | <p><b>100113/1</b></p>  <p>JTAS CARB.CORCEL ANO 1969 SOLEX GAS</p>   | <p><b>100130/2</b></p>  <p>JTAS CARB.ESCORT CHT 1.6 SOLEX DPL. BLFA</p> | <p><b>100130/4</b></p>  <p>JTAS CARB.ESCORT CHT 1.6 SOLEX DPL. BLFA 30/34 (2 BASES)</p> |
| <p><b>100170/1</b></p>  <p>JTAS CARB.MOTORCRAFT MOTOR 302</p>                      | <p><b>100228/4</b></p>  <p>JTAS CARB.CORCEL 1974 - WEBER DFV 228</p> | <p><b>100460/1</b></p>  <p>JTAS CARB.ESC.CHT/BEL/SCALA/D.REY 83/460</p> |  |



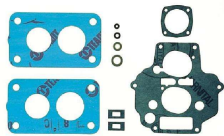

**015 JUNTAS CARBURADOR - GM**

|   |  |   |  |
|---|--|---|--|
| <p><b>100040/2</b></p>  <p>JTAS CARB.CHEV 1.6 GAS./ALC.S/CALÇO</p> | <p><b>100040/6</b></p>  <p>JTAS CARB.CHEV.1.6 GAS/ALC.C/CALÇO-SOLEX 35 PDSI</p> | <p><b>100050/1</b></p>  <p>JTAS CARB.OPALA /CHEV.HAT/MARAJÓ 78/...SOLEX DPL</p> | <p><b>100050/5</b></p>  <p>JTAS CARB.OPALA/CORCEL SOLEX DUPLO 34 SEIE</p> |
|---|--|---|--|







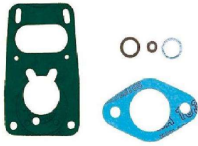

**015 JUNTAS CARBURADOR - GM**

|  |   |  |  |
|--|---|--|--|
| <p><b>100050/7</b></p>  <p>JTAS CARB.OPALA/CHEV.C/COL.-SOLEX DPL.34 SEIE</p>            | <p><b>100118/1</b></p>  <p>JTAS CARB.CHEVETTE 1.4 76/... GAS.SOLEX 34 PDSI</p>       | <p><b>100130/1</b></p>  <p>JTAS CARB.MONZA SR 1.8-SOLEX DPL BLFA</p>       | <p><b>100130/3</b></p>  <p>JTAS CARB.MONZA SR.1.8-CHT1.6-SOLEX BLFA 30/34</p>           |
| <p><b>100160/1</b></p>  <p>JTAS CARB.MONZA 1.6/1.8 82-SOLEX 35 ALFA 1</p>               | <p><b>100175/2</b></p>  <p>JTAS CARB.KADET 1.8 / ESC/ APOL.1.8 DPL. 2E</p>           | <p><b>100175/4</b></p>  <p>JTAS CARB.MONZA 2.0 / SANT-SOLEX DPL. 2E</p>    | <p><b>100176/2</b></p>  <p>JTAS CARB.KADET/SANT.2.0/MZA SOLEX 3E</p>                    |
| <p><b>100182/1</b></p>  <p>JTAS CARB.OPALA/CARV/VERAN 71 SOLEX SPL 40 EIS</p>          | <p><b>100186/1</b></p>  <p>JTAS CARB.OPALA/A10/A20/FORD F1000-ALC.SOLEX 40 DEIS</p> | <p><b>100190/2</b></p>  <p>JTAS CARB.MONZA 1.6/1.8 -WEBER 190 S/CALÇO</p> | <p><b>100190/4</b></p>  <p>JTAS CARB.MONZA 1.6/1.8- WEBER 190 C/CALÇO</p>              |
| <p><b>100228/1</b></p>  <p>JTAS CARB.CHEVROLET C-10/WILLYS 72- WEBER DFV 228</p>      | <p><b>100228/2</b></p>  <p>JTAS CARB.OPALA/CARAVAN 72/.. WEBER DFV 228</p>         | <p><b>100228/3</b></p>  <p>JTAS CARB.CHEV/HATCH/MARJ 1.4/1.6 DFV 228</p> | <p><b>100446/1</b></p>  <p>JTAS CARB.OPALA SS/CARAV/DGE/PU GTB/DIPL.WEBER DFV 446</p> |
| <p><b>100450/2</b></p>  <p>JTAS CARB.CHEV.1.4/1.6 83/...WEBER DPL.450-MINI PROGR.</p> | <p><b>100460/3</b></p>  <p>JTAS CARB.CHEV.1.6/CHEV.JR 88-WEBER 460</p>             |  |  |



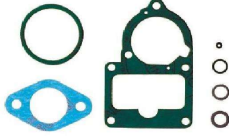
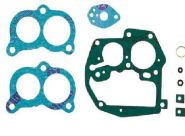

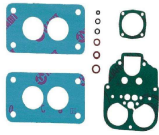
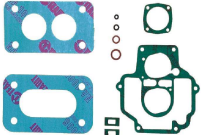
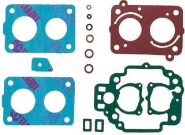
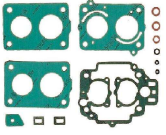

**020 JUNTAS CARBURADOR - VW**

|   |  |   |  |
|---|--|---|--|
| <p><b>100040/1</b></p>  <p>JTAS CARB. PASSAT LS-SOLEX 35 PDSIT S/BORR- S/CALÇO</p> | <p><b>100040/3</b></p>  <p>JTAS CARB. PASSAT LS-SOLEX 35 PDSIT S/BORR.C/CALÇO</p> | <p><b>100040/4</b></p>  <p>JTAS CARB.PASSAT LS-SOLEX 35 PDSIT C/BORR. S/CALÇO</p> | <p><b>100040/5</b></p>  <p>JTAS CARB.PASSA LS-SOLEX 35 PDSIT C/BORR.C/CALÇO</p> |
|---|--|---|--|

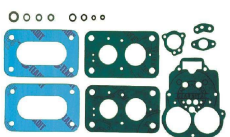
**020 JUNTAS CARBURADOR - VW**

|  |   |  |  |
|--|---|--|--|
| <p><b>100111/1</b></p>  <p>JTAS CARB.SEDAN 1200 - SOLEX 28 PIC</p>              | <p><b>100112/1</b></p>  <p>JTAS CARB.SEDAN 1300/1500 /BRAS-SIMPL-SOLEX 30 PIC</p>        | <p><b>100112/2</b></p>  <p>JTAS CARB.GOL 1300 ANO 83-SOLEX 30 PIC</p>          | <p><b>100114/1</b></p>  <p>JTAS CARB.BRASÍLIA/VW 1600-SOLEX 32 PDSIT-DPL CARB.</p>        |
| <p><b>100114/2</b></p>  <p>JTAS CARB.VARIANT/TL/TC-SOLEX 32 PDSIT-DPL CARB.</p> | <p><b>100117/1</b></p>  <p>JTAS CARB.VW 1600 ANO 1983/84-SOLEX 30 PDSIT</p>              | <p><b>100175/1</b></p>  <p>JTAS CARB.SANTANA/APOLLO 1.8 -SOLEX 2E</p>          | <p><b>100175/3</b></p>  <p>JTAS CARB.PASSAT GTS/GOL 1.8/PAST-POINTER SOLEX DPL ( 2E )</p> |
| <p><b>100176/1</b></p>  <p>JTAS CARB.SANTANA 2000/MONZA SOLEX 3E</p>           | <p><b>100200/1</b></p>  <p>JTAS CARB.PASSAT TS IMPORT-SOLEX 32/34 DIDTA</p>             | <p><b>100450/1</b></p>  <p>JTAS CARB.PASSAT/GOL/VOY/PAR/SAV 1.6 WEBER 450</p> | <p><b>100460/6</b></p>  <p>JTAS CARB.GOL 1000/GOL/PAR/SAV.1.6 460</p>                    |
| <p><b>100495/1</b></p>  <p>JTAS CARB.GOL/VOY/PAR/SAV/ESCT 1.8 TLDZ</p>        | <p><b>100495/4</b></p>  <p>JTAS CARB.GOL/VOY/PAR/SAV/ESC-1.8-WEBER TLDZ 495-INT.NA</p> |  |  |

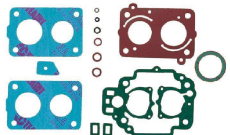
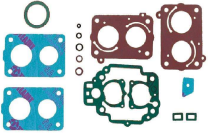
**025 JUNTAS CARBURADOR - ELETRONICO**





|  |   |   |  |
|--|---|---|--|
| <p><b>100150/1</b></p>  <p>JTAS CARB.LADA LAIKA/NIVA 1.600 -WEBER IMPORTADO</p> | <p><b>100150/2</b></p>  <p>JTAS CARB.LADA SAMARA/NIVA 1600-WEBER IMPORTADO</p> | <p><b>150175/1</b></p>  <p>JTAS CARB.VW SANTANA 2000 - 2 CE ELETRONICO</p>    | <p><b>150176/1</b></p>  <p>JTAS CARB.VW SANTANA 2000 -3 CE ELETRONICO</p> |
| <p><b>150489/1</b></p>  <p>JTAS CARB.TOWNER/PICK-UP/FURGÃO/ELETRONICO</p>       | <p><b>150495/1</b></p>  <p>JTAS CARB.VW GOL/VOY/PARATI/SAV-TLDE</p>            | <p><b>150495/2</b></p>  <p>JTAS CARB.LOGUS/APOL/VER/ESCORT XR3-ELETRONICO</p> | <p><b>150500/1</b></p>  <p>JTAS CARB.RENAULT 21/NEVADA SOLEX 34 TEIE</p>  |





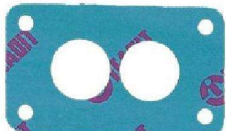

**025 JUNTAS CARBURADOR - ELETRONICO**

|  |  |  |  |
|--|--|--|--|
| <p><b>150501/1</b></p>  <p>JTAS CARB. HYUNDAI EXCEL GL/GLS CONV. ATE 94 TODOS FBC</p> |  |  |  |
|--|--|--|--|

**030 JUNTAS AVULSAS CARBURADOR**

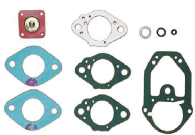

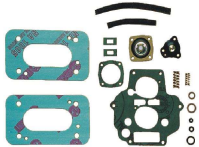
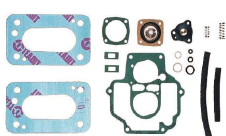
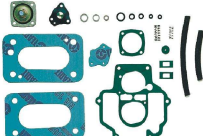
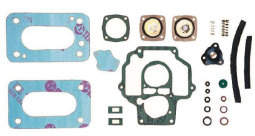



|   |   |  |  |
|---|---|--|--|
| <p><b>300050/H</b></p>  <p>JTA CARB. CHEVETTE WEBER-M.PROGR.(T)</p>              | <p><b>300112/B</b></p>  <p>JTA CARB.BASE SEDAN 1300/1500/SIMPLES (PHMR 1,5MM)</p>        | <p><b>300130/B</b></p>  <p>JTA CARB.BASE X BLFA 30/34 MONZA SR 1.8 (PHMR 0,7M)</p>         | <p><b>300450/B</b></p>  <p>JTA CARB.BASE MINI PROGRESSIVO (FECHADA)(PHMR 0,7MM)</p> |
| <p><b>300460/C</b></p>  <p>JTA CARB. BASE CARB.FECHADA (460/1) (PHMR 0,7MM)</p> | <p><b>300460/F</b></p>  <p>JTA CARB.TAMPA CHT GOL 1000/FIAT ABERTA(GUARNITAL 0,8MM)</p> | <p><b>300460/W</b></p>  <p>JTA INTERMEDIÁRIA ENTRE A TAMPA E ELEMENTO FILTRANTE 460/1</p> |  |

**035 KIT CARBURADOR - FIAT (SIMPLES)**





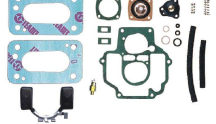
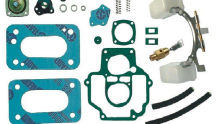
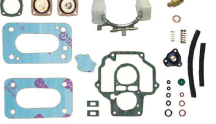
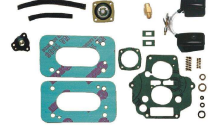

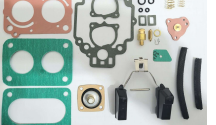
|   |  |  |  |
|---|--|--|--|
| <p><b>500070/1</b></p>  <p>KIT CARB.FIAT147/FIO/PANOR.1050/1300 SOLEX 32 DIS SPLS ALC.</p> | <p><b>500070/2</b></p>  <p>KIT CARB.147/FIO/PANOR.1050/1300 SOLEX 32 DIS SPLS-GAS</p> | <p><b>500160/2</b></p>  <p>KIT CARB.147 06/79/.../UNO/PRÊMIO/ELBA 83/SOLEX 35 ALFA 1</p> | <p><b>500190/1</b></p>  <p>KIT CARB.1050/1300 WEBER 190 SPLS.</p>               |
| <p><b>500460/2</b></p>  <p>KIT CARB.UNO SX 1300 UNO/PRM.1500 -WEBER 460 DUP.</p>           | <p><b>500460/4</b></p>  <p>KIT CARB.UNO/MILLE BRIO/ELBA 1.6R-WEBER 460 DPL</p>        | <p><b>500460/5</b></p>  <p>KIT CARB.TEMPRA 2.0-8V-1992/...GAS.WEBER 460 DPL</p>          | <p><b>500460/7</b></p>  <p>KIT CARB.TEMPRA 2.0-8V.1992/...ALC.WEBER 460 DPL</p> |
| <p><b>500495/2</b></p>  <p>KIT CARB.UNO/PRMIO/ELBA-90/...WEBER TLDF495</p>                 | <p><b>500495/5</b></p>  <p>KIT CARB.UNO/PRM/ELB 93/C/IG.MAP.WEBER TLDF495</p>         |  |  |

**045 KIT CARBURADOR - FIAT (COMPLETO)**

**045 KIT CARBURADOR - FIAT (COMPLETO)**

|   |  |  |   |
|---|--|--|---|
| <p><b>690070/1</b></p>  <p>KIT CARB. FIAT 147/FIOR/PANOR.1050/1300 SOLEX 32 DIS ALC.</p> | <p><b>690070/2</b></p>  <p>KIT CARB. FIAT 147/FIOR/PANOR.1050/1300 SOLEX 32 DIS GAS</p> | <p><b>690160/2</b></p>  <p>KIT CARB. FIAT 147 06/79..UNO/PREM./ELBA 83/..SOLEX 35 ALFA 1</p> | <p><b>690190/1</b></p>  <p>KIT CARB. FIAT 1050/1300 CARB.WEBER SIMP. 190</p>         |
| <p><b>690460/2</b></p>  <p>KIT CARB. UNO SX 1300/UNO/PREM.1500 WB DPL 460 ALC.</p>       | <p><b>690460/4</b></p>  <p>KIT CARB. UNO MILLE BRIO/UNO/ELBA 1.6R WEBER DPL.460</p>     | <p><b>690460/5</b></p>  <p>KIT CARB. FIAT TEMPRA 2.0 8V.92/GAS.WEBER 460</p>                 | <p><b>690460/7</b></p>  <p>KIT CARB. FIAT TEMPRA 2.0 8V.92/... ALC.WEBER DPL.460</p> |
| <p><b>690460/9</b></p>  <p>KIT CARB. UNO SX 1300/UNO/PREM/1500 WEBER DPL. 460 GAS</p>   | <p><b>690495/2</b></p>  <p>KIT CARB. UNO/PREM/ELBA 90/...WEBER TLDF495</p>             | <p><b>690495/5</b></p>  <p>KIT CARB. UNO/PREM/ELBA 93/..WEBER TLDE 495 IG MAP.</p>          | <p><b>690495/7</b></p>  <p>KIT CARB. UNO/PREM/ELBA 90/...WEBER TLDF 495 ALC.</p>    |

**050 KIT CARBURADOR - FORD (SIMPLES)**

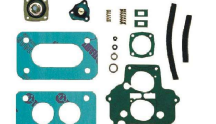
|  |  |  |  |
|--|--|--|--|
| <p><b>500050/2</b></p>  <p>KIT CARB.CORC./BEL/D.REY/PAMPA 78/83-CARB.SOLEX 34 SEIE</p>        | <p><b>500050/4</b></p>  <p>KIT CARB. CORCEL SOL.DPL. SEM VAL.MAX.</p>                         | <p><b>500050/5</b></p>  <p>KIT CARB.OPALA /CHEV.HACTH/MARAJÓ 78/.CORC./BEL/D.REY/PAMPA 78/83 SOLEX 34 SEIE</p> | <p><b>500130/4</b></p>  <p>KIT CARB.ESCORT/GOL 1.6 CHTSOLEX BLFA 30/34 DUP.</p> |
| <p><b>500228/4</b></p>  <p>KIT CARB.CORC./BEL/D.REY/PAMPA 1.4/1.6-CHEV.1.4 CARB.WEBER DFV</p> | <p><b>500228/5</b></p>  <p>KIT CARB.CORC./BEL/D.REY/PAMPA 1.4/1.6-CHEV.1.4 CARB.WEBER DFV</p> | <p><b>500460/1</b></p>  <p>KIT CARB.CORC./BEL/D.REY/SACALA 83/..ESC.CHT</p>                                    |  |







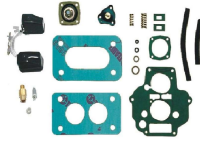



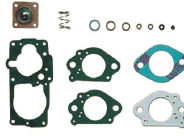



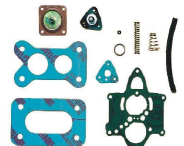

**060 KIT CARBURADOR - FORD (COMPLETO)**

|  |  |   |   |
|--|--|---|---|
| <p><b>690130/4</b></p>  <p>KIT CARB. ESCORT/GOL 1.6 CHT SOLEX BLFA 30/34 DUP.</p> | <p><b>690228/4</b></p>  <p>KIT CARB. CORC./BEL/D.REY/CHEV/PAMPA 1.4/1.6 GAS.DFV 228</p> | <p><b>690228/5</b></p>  <p>KIT CARB. CORC./BEL/D.REY/PAMPA 1.4/1.6 CHEV.1.4 ALC.- DFV 228</p> | <p><b>690460/1</b></p>  <p>KIT CARB. CORC./BEL/D.REY/SCA/ESCT.CHT WB DPL.460 ALC</p> |
|--|--|---|---|

**060 KIT CARBURADOR - FORD (COMPLETO)**

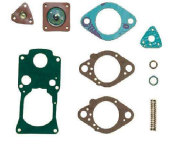
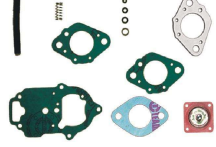
|  |  |  |  |
|--|--|--|--|
| <p><b>690460/8</b></p>  <p>KIT CARB. CORC/BEL/D.REY/SCA/83/..ESCT<br/>CHT WB DPL.460 GAS.</p> |  |  |  |
|--|--|--|--|

**065 KIT CARBURADOR - GM (SIMPLES)**

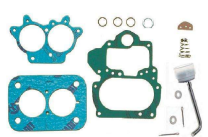





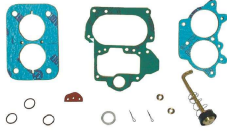
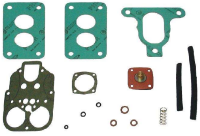
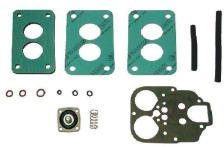
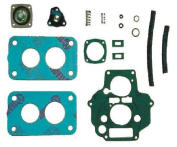



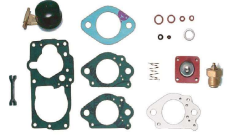
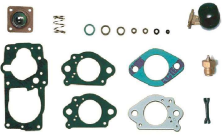
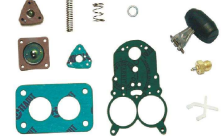

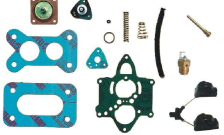
|  |   |  |   |
|--|---|--|---|
| <p><b>500040/2</b></p>  <p>KIT CARB.CHEV. 1.4/ 1.6/GAS.SOLEX 35<br/>PDSI</p>              | <p><b>500040/6</b></p>  <p>KIT CARB.CHEV.1.4/1.6 / ALCO.CARB . SOLEX<br/>35 PDSI</p>           | <p><b>500050/1</b></p>  <p>KIT CARB.OPALA /CHEV.HACTH/MARAJÓ<br/>78/ SOLEX 34 SEIE</p>               | <p><b>500050/7</b></p>  <p>KIT CARB.CHEV./HATCH/MAR.78/...C/<br/>COLET.SOLEX DPL.34 SEIE</p>             |
| <p><b>500118/1</b></p>  <p>KIT CARB.CHEV./HATCH/MARAJÓ 1.4<br/>GAS.SOLEX 34 PDSI</p>     | <p><b>500130/3</b></p>  <p>KIT CARB.MONZA 1.8/ESC./GOL<br/>CHT1.6-SOLEX BLFA 30/34</p>        | <p><b>500160/1</b></p>  <p>KIT CARB.MONZA 1.6/1.8-82/...UNO/ELBA<br/>1300 86/...SOLEX 35 ALFA 1</p> | <p><b>500175/2</b></p>  <p>KIT CARB.MZA/KDT 1.8/ 2.0 /ESC./VER/SANT/<br/>GOL 1.8/2.0 SOLEX 2E7</p>      |
| <p><b>500175/7</b></p>  <p>KIT CARB.MONZA/ESCT/SANT/GOL C/<br/>BAQ.SOLEX DPL.2E</p>     | <p><b>500175/8</b></p>  <p>KIT CARB. SANT.APOS91 DIAF.S/ESFERA<br/>CARB.SOLEX 2E S/FILT.</p> | <p><b>500176/2</b></p>  <p>KIT CARB.GM 1.8/2.0/2.5/4.1-VW 1.8/2.0<br/>-FORD 2.0 -SOLEX DPL.3E</p>  | <p><b>500176/3</b></p>  <p>KIT CARB.GM 1.8/2.02.5/4.1/VW 1.8/2.0/FORD<br/>2.0 C/FILT.SOLEX DPL. 3E</p> |
| <p><b>500176/4</b></p>  <p>KIT CARB. CARB. 3E GM/VW 1.8/2.0 S/<br/>FILTROS C/ CALÇO</p> | <p><b>500182/1</b></p>  <p>KIT CARB.OPALA/CARV/VER.<br/>71/...JEEP/RURAL/SOLEX 40 EIS</p>    | <p><b>500186/1</b></p>  <p>KIT CARB.OPALA/CAR./PICK-UP 2500<br/>4CIL.73/84/JEEP/RURAL/40 DEIS</p>  | <p><b>500190/2</b></p>  <p>KIT CARB.MONZA 1.6/1.8 CHEV.JR. WEBER<br/>190 SPLS.</p>                     |
| <p><b>500228/1</b></p>  <p>KIT CARB.C10/ CAMINHAO 6 CIL. 72/...<br/>WILLYS DFV 228</p>  | <p><b>500228/2</b></p>  <p>KIT CARB.OPALA/CARAVAN 72 WEBER DFV<br/>228</p>                   | <p><b>500228/3</b></p>  <p>KIT CARB.CHEV.-1.4/1.6<br/>73/...CORC/BEL.I/D.REY 1.6 DFV 228</p>       | <p><b>500446/1</b></p>  <p>KIT CARB.OPALA SS/CAR.4/6 CIL/PUMA<br/>GTB/DIPL.DFV 446 GAS</p>             |

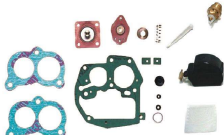

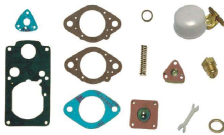
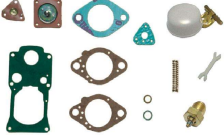
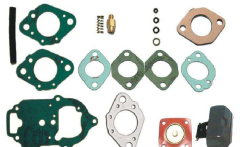
**065 KIT CARBURADOR - GM (SIMPLES)**

|   |   |  |  |
|---|---|--|--|
| <p><b>500446/2</b></p>  <p>KIT CARB.OPALA SS/CAR.4/6CIL/PUMA GTB/DIPL.DFV 446 ALC.</p> | <p><b>500450/2</b></p>  <p>KIT CARB.GM CHEV. 1.4/1.6 CARB.WEBER 450 MINI PROG.</p> | <p><b>500450/B</b></p>  <p>KIT CARB. MINI PROG. PST/GOL/VGE/PRT (DIAF.403.622/D) C/CALÇO</p> | <p><b>500460/3</b></p>  <p>KIT CARB.GM CHEV.1.6/ CHEV. JR. 88 CARB. WEBER 460 DUPL.</p> |
|---|---|--|--|



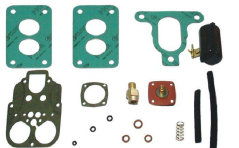



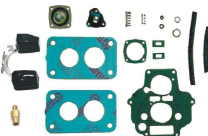





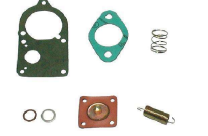

**075 KIT CARBURADOR - GM (COMPLETO)**

|  |   |  |  |
|--|---|--|--|
| <p><b>690040/2</b></p>  <p>KIT CARB. CHEVETTE 1.4/1.6 GAS.SOLEX SPLS 35 PDSI</p>                | <p><b>690040/6</b></p>  <p>KIT CARB. CHEV 1.4/1.6 ALC.SOLEX 35 PDSI</p>                      | <p><b>690050/1</b></p>  <p>KIT CARB. OPALA 4 CC/CHEV.74/75/SOLEX 34 SEIE DPL.GAS</p>         | <p><b>690050/3</b></p>  <p>KIT CARB. OPALA/CARAV-2500/PICK-UP 6C-SOLEX 34 SEIE DPLALC.</p>      |
| <p><b>690118/1</b></p>  <p>KIT CARB. CHEV/HATCH/MARA/76/82 GAS.SOLEX 34 PDSI SPLS</p>          | <p><b>690130/3</b></p>  <p>KIT CARB. MONZA 1.8 ALC.SOLEX DPL. BLFA 30/34</p>                | <p><b>690160/1</b></p>  <p>KIT CARB. MONZA 1.6/1.8- 82/...SOLEX 35 ALFA 1 GAS</p>           | <p><b>690160/3</b></p>  <p>KIT CARB. MONZA 1.6/1.8-82/...SOLEX 35 ALFA 1 ALC.</p>              |
| <p><b>690175/2</b></p>  <p>KIT CARB. MZA/KADT/ESCT/VER/SANT/GOL 1.8/2.0-SOLEX 2E7 GAS/ALC</p> | <p><b>690176/2</b></p>  <p>KIT CARB. GM 1.8/2.0/2.5/4.1 VW 1.8/2.0 FORD 2.0 SOLEX 3E</p>   | <p><b>690182/1</b></p>  <p>KIT CARB. OPAL/CARV/VERA-71/ RURAL/F-75 4/6CIL SOLEX 40 EIS</p> | <p><b>690186/1</b></p>  <p>KIT CARB. OPAL/CARV/PICK-UP 2500 4CIL.RURAL SOLEX 40 DEIS</p>      |
| <p><b>690190/2</b></p>  <p>KIT CARB. MONZA 1.6/1.8/CHEV.JR WEBER 190 SPLS.</p>                | <p><b>690228/1</b></p>  <p>KIT CARB. C-10/CAMINHÃO 6CIL. 72/... WILLYS DFV 228</p>         | <p><b>690228/2</b></p>  <p>KIT CARB. OPALA/CARAVAN 72 WEBER DFV 228</p>                    | <p><b>690228/3</b></p>  <p>KIT CARB. CHEV.1.4/1.6-73/...CORC/BEL II 1.4/D.REY 1.6 DFV 228</p> |
| <p><b>690422/1</b></p>  <p>KIT COMPLETO CARB. TRAFIC 2.2 GASOLINA HOLLEY 1908</p>             | <p><b>690446/1</b></p>  <p>KIT CARB. OPALA SS/CARAV. 4/6CIL./PUMA GTB DFV 446 DPL. GAS</p> | <p><b>690446/2</b></p>  <p>KIT CARB. OPALA SS/CARAV 4/6CIL./PUMA GTB DFV 446 DPL. ALC</p>  | <p><b>690450/2</b></p>  <p>KIT CARB. CHEV-1.4/1.6 WEBER 450 MINI PROG. ALC/GAS</p>            |

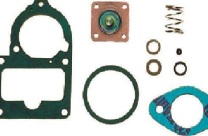
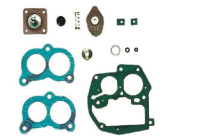

**075 KIT CARBURADOR - GM (COMPLETO)**

|   |  |  |  |
|---|--|--|--|
| <p><b>690460/3</b></p>  <p>KIT CARB. CHEV 1.6/ CHEV. JUNIOR 88<br/>WEBER 460 DPL</p> |  |  |  |
|---|--|--|--|

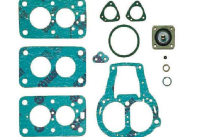
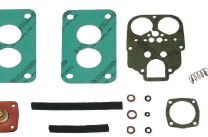



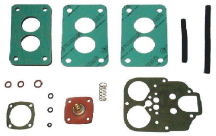
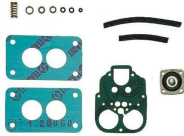
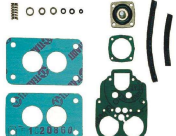
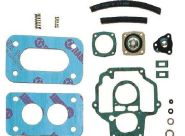

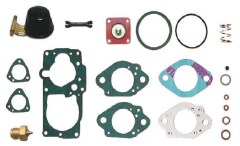

**080 KIT CARBURADOR - VW (SIMPLES)**

|   |  |  |  |
|---|--|--|--|
| <p><b>500040/1</b></p>  <p>KIT CARB. PASSAT LS/VOY. 1.5 GAS.SOLEX<br/>35 PDSIT.C/CALÇO</p>             | <p><b>500040/5</b></p>  <p>KIT CARB. PASSAT LS/VOY. 1.5 ALC.SOLEX<br/>35 PDSIT C/CALÇO</p>          | <p><b>500112/1</b></p>  <p>KIT CARB.VW SEDAN 1300/1500 BRAS<br/>SOLEX 30 PIC</p>             | <p><b>500112/3</b></p>  <p>KIT CARB.VW 1300/1500 BRAS. SPLS SOLEX<br/>30 PIC C/MOLA RET.</p>            |
| <p><b>500112/4</b></p>  <p>KIT CARB VW 1300 C/ INJETOR</p>  | <p><b>500112/5</b></p>  <p>KIT CARB. VW 1300 C/AGULHA E INJETOR</p>                                | <p><b>500114/1</b></p>  <p>KIT CARB.VW 1600/BRAS/KOMBI/GOL AR<br/>GAS.SOLEX 32 PDSIT</p>    | <p><b>500114/2</b></p>  <p>KIT CARB.VW 1600/BRAS/KOMBI/GOL AR<br/>ALC.SOLEX 32 PDSIT</p>               |
| <p><b>500114/3</b></p>  <p>KIT CARB.VW 1600/BRAS/KB/GOL AR<br/>GAS.SOLEX 32 PDSIT C/MOLA RET</p>     | <p><b>500114/4</b></p>  <p>KIT CARB.VW KOMBI MOD.<br/>91/.GAS/ALC.SOLEX 32 PDSIT</p>              | <p><b>500114/5</b></p>  <p>KIT CARB.KOMBI 91/.GAS/ALC.C/MOLA<br/>RET.SOLEX 32 PDSIT</p>    | <p><b>500114/6</b></p>  <p>KIT CARB. VW 1600/BRAS/KB/GOL<br/>AR-SOLEX 32 PDSIT-C/MOLA RET.INJETOR</p> |
| <p><b>500117/1</b></p>  <p>KIT CARB. 1600 1984/...CARB. SOLEX 30<br/>PDSIT</p>                       | <p><b>500175/4</b></p>  <p>KIT CARB. SANT/GOL1.8/2.0 MZA/KDT1.8/2.0<br/>ESC./VER.SOLEX DPL 2E</p> | <p><b>500175/5</b></p>  <p>KIT CARB.SANT/GOL/MONZA/KDT.1.8/2.0<br/>C/FIL.SOLEX DPL. 2E</p> | <p><b>500175/6</b></p>  <p>KIT CARB.SANT. APÓS 91 DIAF. S/ESF.<br/>C/FILT.CARB.SOLEX 2E</p>           |
| <p><b>500175/9</b></p>  <p>KIT CARB. 2E APÓS 91 (DIAF. 174099/D<br/>S/ESFERA) S/ FILTROS C/CALÇO</p> | <p><b>500176/1</b></p>  <p>KIT CARB.VW 1.8/2.0 FORD 2.0 CARB.SOLEX<br/>DPL.3E</p>                 | <p><b>500200/1</b></p>  <p>KIT CARB.PASSAT TS IMPORT.SOLEX 32/35<br/>DIDTA</p>             | <p><b>500450/1</b></p>  <p>KIT<br/>CARB.PASSAT/GOL/VOY/PAR/SAV.1.6-CORC<br/>EL II-WEBER 450</p>       |

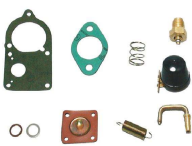
**080 KIT CARBURADOR - VW (SIMPLES)**

|  |   |   |  |
|--|---|---|--|
| <p><b>500450/3</b></p>  <p>KIT CARB. GOL/VOY/PAR/SAV. C/ BAQ. CARB. WEBER 450</p> | <p><b>500450/4</b></p>  <p>KIT CARB. GOL/VOY/PARATI/SAV.1.6-CORC.II 450 M.PROG.(DIAF.403625/D PINO ALTO)</p> | <p><b>500450/A</b></p>  <p>KIT CARB.PAST/GOL/VOY/PAR/SAV.1.6-CORC II/450 MINI DIAF.MOLD</p> | <p><b>500460/6</b></p>  <p>KIT CARB.GOL 1000 /GOL/PAR/SAV.1.6/1.8 89/WEBER 460 AE</p> |
| <p><b>500495/1</b></p>  <p>KIT CARB.GOL/VOY/PAR/SAV/ESCT 1.8-WEBER TLDZ495</p>    |   |   |  |

**090 KIT CARBURADOR - VW (COMPLETO)**

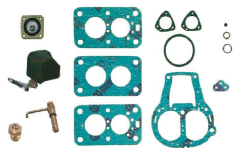
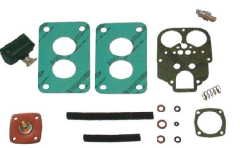
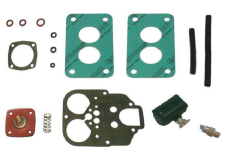
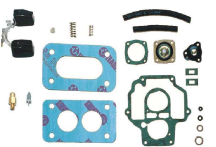
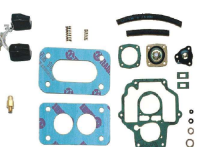
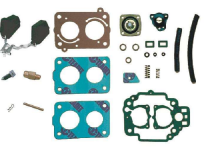
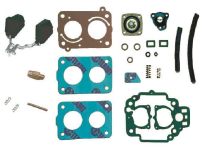
|  |   |  |  |
|--|---|--|--|
| <p><b>690040/1</b></p>  <p>KIT CARB. PASSAT LS /VOY/1.5 GAS.C/CALÇO SOLEX 35 PDSIT</p>       | <p><b>690040/5</b></p>  <p>KIT CARB. PAST LS/VOY/1.5 ALC. C/CALÇO.SOLEX 35 PDSIT SPLS</p>     | <p><b>690112/1</b></p>  <p>KIT CARB. VW SEDAN 1300/1500 BRAS.SPLS SOLEX 30 PIC</p>        | <p><b>690114/1</b></p>  <p>KIT CARB. VW 1600/BRAS./KB/GOL AR/ GAS.SOLEX 32 PDSIT</p>           |
| <p><b>690114/2</b></p>  <p>KIT CARB. VW 1600/BRAS./KB/GOL AR/ALC.SOLEX 32 PDSIT</p>         | <p><b>690114/4</b></p>  <p>KIT CARB. KOMBI MODER.91/...SOLEX 32 PDSIT DPL CARB.GAS</p>       | <p><b>690114/5</b></p>  <p>KIT CARB. KOMBI MODER. 91/..SOLEX 32 PDSIT DPL CARB. ALC.</p> | <p><b>690175/4</b></p>  <p>KIT CARB. SANT/GOL/ MONZA/KADET 1.8/2.0-ESCT/VER-SOLEX DPL.2E</p>  |
| <p><b>690176/1</b></p>  <p>KIT CARB. VW 1.8/2.0 FORD 2.0 CARB.SOLEX DPL. 3E</p>             | <p><b>690200/1</b></p>  <p>KIT CARB. PASSAT TS IMPORT. SOLEX 32/35 DIDTA</p>                 | <p><b>690450/1</b></p>  <p>KIT CARB. PAST/GOL/VOY/PAR/SAV.1.6 CORC-II WB 450 MINI PR</p> | <p><b>690450/3</b></p>  <p>KIT CARB. PAST/GOL/VOY/PAR/SAV.1.6 CORC-II WB 450-MINI PR-ALC.</p> |
| <p><b>690460/0</b></p>  <p>KIT CARB. GOL1000/GOL/PAR/SAV.1.6/1.8 89/ AE WB DPL.460 ALC.</p> | <p><b>690460/6</b></p>  <p>KIT CARB. GOL1000/GOL/PAR/SAV.1.6/1.8 89/..AE WB DPL.460 GAS.</p> | <p><b>690495/1</b></p>  <p>KIT CARB. GOL/VOY/PAR/SAV/ESCT.1.8.WEBER TLDZ495 GAS.</p>     | <p><b>690495/6</b></p>  <p>KIT CARB. GOL/VOY/PAR/SAV/ESCT.1.8 WEBER TLDZ495 ALC.</p>          |

**095 KIT CARBURADOR ELETR. (SIMPLES)**



**095 KIT CARBURADOR ELETR. (SIMPLES)**

|  |   |   |  |
|--|---|---|--|
| <p><b>500150/1</b></p> <p>KIT CARB. LAIKA/NIVA 1.600 CARB. WEBER IMPORT.</p> | <p><b>500150/2</b></p> <p>KIT CARB. SAMARA / NIVA 1.600 CARB. WEBER IMPORT.</p>           | <p><b>550175/1</b></p> <p>KIT CARB. SANTANA 2000 CARB. SOLEX 2-CE ELETRONICO</p>    | <p><b>550176/1</b></p> <p>KIT CARB. VW SANTANA 2000 CARB. SOLEX 3 - CE ELETRONICO</p>      |
| <p><b>550489/1</b></p> <p>KIT CARB. TOWNER - CARB. ELETRONICO</p>            | <p><b>550495/1</b></p> <p>KIT CARB. GOL/VOYAGE/PARATI/SAVEIRO CARB. WEBER TLDE ELETR.</p> | <p><b>550495/2</b></p> <p>KIT CARB. LOGUS/APOLLO/VERONA CARB. WEBER TLDE ELETR.</p> | <p><b>550495/3</b></p> <p>KIT CARB. UNO/PREMIO/ELBA 93/... CARB. WEBER TLDE 495 ELETR.</p> |

**105 KIT CARB ELETRONICO (COMPLETO)**

|   |   |  |   |
|---|---|--|---|
| <p><b>695175/1</b></p> <p>KIT CARB. SANT. 2000 CARB. ELET. 2CE GAS/ALC</p>    | <p><b>695176/1</b></p> <p>KIT CARB. SANT. 2000 CARB. ELET. 3CE GAS/ALC</p>        | <p><b>695489/1</b></p> <p>KIT CARB. TOWNER CARB. ELET. GAS.</p>                | <p><b>695495/1</b></p> <p>KIT CARB. GOL/VOY./PARATI/SAVE. CARB. ELET. TLDE GAS.</p> |
| <p><b>695495/2</b></p> <p>KIT CARB. LOGUS/APOL/VER/ CARB. ELET. TLDE GAS.</p> | <p><b>695495/3</b></p> <p>KIT CARB. GOL/VOY/PARATI/SAV/ CARB. ELET. TLDE ALC.</p> | <p><b>695495/4</b></p> <p>KIT CARB. LOGUS/APOL/VERO/ CARB. ELET. TLDE ALC.</p> |   |

**110 KIT DE GICLEUR SOLEX - FIAT**

|   |   |   |  |
|---|---|---|--|
| <p><b>160.522</b></p> <p>KIT GICLEUR SOLEX FIAT PANOR/SPAZ/OGGI/UNO/PREM/ELBA 1.3 83/88 35ALFA 1-ÁLCOOL<br/>GPMS 140/AG PASSAT/GMLS 70/ÁLCOOL</p> | <p><b>70.103</b></p> <p>KIT GICLEUR SOLEX FIAT 32 DIS 3 (4.386.239)10/78...-GASOLINA<br/>GAPR 130/MLF 47/CATE FIAT 190/T-2115-40/GASOLINA</p> | <p><b>70.502</b></p> <p>KIT GICLEUR SOLEX FIAT 32 DIS 2 (70.542)6/79...-ÁLCOOL<br/>GAPR 132/ML FIAT 65/CATE FIAT 180/T-2115-70/ÁLCOOL</p> |  |
|---|---|---|--|

**115 KIT DE GICLEUR SOLEX - FORD**

|   |   |  |  |
|---|---|--|--|
| <p><b>130.524</b></p> <p>KIT GICLEUR SOLEX FORD CORCEL/BELINA 83/88 1.6 PAMPA 83/89 D.REY 83/ BLFA-ÁLCOOL<br/>TUBO BLFA 12821/AG BLFA/ML BLFA 140x65/T-2115-80/ÁLCOOL</p> | <p><b>130.528</b></p> <p>KIT GICLEUR SOLEX FORD ESCORT/VERONA 1.6 CARB. BLFA-GASOLINA<br/>TUBO BLFA 12822/ML BLFA 135x55/AG BLFA/T-2115-50/GASOLINA</p> | <p><b>130.529</b></p> <p>KIT GICLEUR SOLEX FORD ESCORT/VERONA 1.6 91/CARB. BLFA-ÁLCOOL<br/>TUBO BLFA 12823/ML BLFA 140x80/AG BLFA/T-2115-80/ÁLCOOL</p> | <p><b>170.523</b></p> <p>KIT GICLEUR SOLEX FORD PAMPA 1.8 91/92 CARB. 2E7-ÁLCOOL<br/>GAPR 122-127/ML 2E7-3E 145x62/AG S-M/T-2109-60/ÁLCOOL</p> |
|---|---|--|--|

**115 KIT DE GICLEUR SOLEX - FORD**

|   |   |  |  |
|---|---|--|--|
| <p><b>170.534-1</b></p> <p>KIT GICLEUR SOLEX FORD ESCORT/VERONA 1.8 10/92... CARB.2ECE-GASOLINA<br/>GAPR 105-115/AG S-M/ML 2E7-3E 135x47/T-2108-35/GASOLINA</p> | <p><b>170.538</b></p> <p>KIT GICLEUR SOLEX FORD ESCORT 1.8 CARB 2E7-ÁLCOOL<br/>GAPR 130-145/AG S-M/ML 2E7-3E 145x60/T-2108-70/ÁLCOOL</p>            | <p><b>170.540</b></p> <p>KIT GICLEUR SOLEX FORD ESCORT 1.8 6/93...CARB 2 ECE-ÁLCOOL<br/>GAPR 122-145/AG S-M/ML 2E7-3E 125x57/T-2115-150/ÁLCOOL</p> | <p><b>175.537</b></p> <p>KIT GICLEUR SOLEX FORD ESCORT 1.8/VERONA 1.8 CARB. 2E7-GASOLINA<br/>GAPR 112-120/ML 2E7-3E 145x52/AG S-M/T-2108-35/GASOLINA</p> |
| <p><b>175.569</b></p> <p>KIT GICLEUR SOLEX FORD ESCORT XR3 89/91 CARB.2E7-ÁLCOOL<br/>GAPR 120-142/ML 2E7-3E 135x72/AG S-M/T-2108-60/ÁLCOOL</p>                  | <p><b>50.543</b></p> <p>KIT GICLEUR SOLEX FORD CORCEL/BELINA2/DELREY 78/83 CARB.34SEIE- GASOLINA<br/>GAPR 120-100/GMLS 55-65/T-2112-60/GASOLINA</p> |  |  |





















**120 KIT DE GICLEUR SOLEX - GM**

|  |   |   |   |
|--|---|---|---|
| <p><b>130.503</b></p> <p>KIT GICLEUR SOLEX GM MONZA 1.8 85/86 CARB.BLFA-GASOLINA<br/>TUBO BLFA 12828/ML BLFA 140x62/AG BLFA/T-2114-50/GASOLINA</p>                           | <p><b>130.504</b></p> <p>KIT GICLEUR SOLEX GM MONZA 1.8 85/86 CARB.BLFA-ÁLCOOL<br/>TUBO BLFA 12827/ML BLFA 120x65/AG BLFA/T-2116-80/ÁLCOOL</p>                | <p><b>160.505</b></p> <p>KIT GICLEUR SOLEX GM MONZA 1.8 82/85 CARB.35 ALFA 1-GASOLINA<br/>GPMS 162/GMLS 70/AG PASSAT/T-2106-50/GASOLINA</p>                           | <p><b>160.506</b></p> <p>KIT GICLEUR SOLEX GM MONZA 1.8 84/85 CARB. 35 ALFA 1-ÁLCOOL<br/>GPMS 172/GMLS 77/AG PASSAT/T-2105-80/ÁLCOOL</p>                                    |
| <p><b>174.522</b></p> <p>KIT GICLEUR SOLEX GM MONZA/KADET 1.8 TM 86/88 CARB.2E7-GASOLINA<br/>GAPR 112-147/ML 2E7-3E 155x52/AG S-M/T-2108-35/GASOLINA</p>                     | <p><b>174.533</b></p> <p>KIT GICLEUR SOLEX GM MONZA 1.8 86/91 - KADET 1.8 CARB.2E7-ÁLCOOL<br/>GAPR 127-162/ML 2E7-3E 140x57/AG S-M/T-2108-60/ÁLCOOL</p>       | <p><b>174.542</b></p> <p>KIT GICLEUR SOLEX GM MONZA 2.0 86/91 - KADET 2.0 CARB.2E7-ÁLCOOL<br/>GAPR 140-167/ML 2E7-3E 140x50/AG S-M/T-2108-55/ÁLCOOL</p>               | <p><b>176.520</b></p> <p>KIT GICLEUR SOLEX GM MONZA 2.0 CARB.3E-GASOLINA<br/>GAPR 127-127/AG S-M/ML2E7-3E-145X52/T-2108-70/GASOLINA</p>                                     |
| <p><b>176.560</b></p> <p>KIT GICLEUR SOLEX GM OPALA/CARAVAN 4 CIL 89/91 CARB.3E-ÁLCOOL<br/>GAPR 140-160/ML 2E7-3E 155x57/AG S-M/T-2109-60/ÁLCOOL</p>                         | <p><b>176.561</b></p> <p>KIT GICLEUR SOLEX GM OPALA/CARAVAN TM E TA 6 CIL. 89/92 CARB.3E-ÁLCOOL<br/>GAPR 157-200/AG S-M/ML 2E7-3E 160x60/T-2109-80/ÁLCOOL</p> | <p><b>40.513</b></p> <p>KIT GICLEUR SOLEX GM CHEVE HATCH/MARJ./CHEVY500 1.6 82/87 CARB.35PDSI-ÁLCOOL<br/>GAPR 172/CAR SOLEX 65/AG PASSAT/GMLS 50/T-2112-60/ÁLCOOL</p> | <p><b>40.516</b></p> <p>KIT GICLEUR SOLEX GM CHEV HATCH/MARAJÓ/CHEVY500 1.6 10/86À05/89 CARB.35PDSI-GAS<br/>GAPR 150/CAR SOLEX 60/AG PASSAT/GMLS-60/T-2105-150/GASOLINA</p> |
| <p><b>40.562</b></p> <p>KIT GICLEUR SOLEX GM CHEVE.HATCH/MARJ. 1.6/CHEVY500 84/86 CARB.35PDSI - GASOLINA<br/>GAPR 150/CAR SOLEX 125/AG PASSAT/GMLS 60/T-2118-50/GASOLINA</p> | <p><b>54.500</b></p> <p>KIT GICLEUR SOLEX GM OPALA/CARAVAN 2500 4 CIL.78/83 CARB.34 SEIE-GASOLINA<br/>GAPR 107-130/GMLS 60-60/T-2118-85/GASOLINA</p>          | <p><b>54.502</b></p> <p>KIT GICLEUR SOLEX GM CHEVETTE HATCH/MARAJÓ 1.4 78/82 CARB.34SEIE-GASOLINA</p>   | <p><b>54.505</b></p> <p>KIT GICLEUR SOLEX GM OPALA/CARAVAN 2500 4 CIL.80/84 CARB.34 SEIE-ÁLCOOL<br/>GAPR 105-125/GMLS 67-65/T-2112-60/ÁLCOOL</p>                            |

**120 KIT DE GICLEUR SOLEX - GM**

|   |  |  |  |
|---|--|--|--|
| <p><b>54.512</b></p>  <p>KIT GICLEUR SOLEX GM OPALA/CARAVAN<br/>4100 6CIL.09/84 À 10/89 CARB.34<br/>SEIE-ÁLCOOL</p> <p>GAPR 160-200/GMLS 55-80/T-2111-150/ÁLCOOL</p> | <p><b>54.531</b></p>  <p>KIT GICLEUR SOLEX GM CHEVETTE HATCH/<br/>MARAJÓ 1.4 80/82CARB.34SEIE-ÁLCOOL</p> <p>GAPR 132-112/GMLS 80-95/T-2105-100/ÁLCOOL</p> | <p><b>54.541</b></p>  <p>KIT GICLEUR SOLEX GM<br/>OPALA/CARAVAN/PICK/VER. 6 CIL CARB.34<br/>SEIE-ÁLCOOL</p> <p>GAPR 160-165/GMLS 75-72/T-2102-50</p> | <p><b>54.552</b></p>  <p>KIT GICLEUR SOLEX GM<br/>OPALA/CARAVAN2500 4 CIL.80/89 CARB.34<br/>SEIE-ÁLCOOL</p> <p>GAPR 145-185/GMLS 77-95/T-2118-50/ÁLCOOL</p> |
|---|--|--|--|

**125 KIT DE GICLEUR SOLEX - VW**

|  |   |  |  |
|--|---|--|--|
| <p><b>112.046</b></p>  <p>KIT GICLEUR SOLEX VW BRASILIA 1.6<br/>TDS/KOMBI 1.6 30PIC 11/75/GASOLINA</p> <p>GAPR 120/CATE 135/AVK/GMLS<br/>70/T-2101-60/GASOLINA</p>                                | <p><b>112.048</b></p>  <p>KIT GICLEUR SOLEX VW 1300 SEDAN 68/74<br/>CARB.30PICS-GASOLINA</p> <p>GP125/GML55/CA125/T-2101-70</p>  | <p><b>112.056</b></p>  <p>KIT GICLEUR SOLEX VW 1500 FUSCAO<br/>72/75 CARB.30PICS-GASOLINA</p> <p>GAPR 122/GMLS 60/AVK/CATE<br/>125/T-2101-60/GASOLINA</p>                            | <p><b>112.078</b></p>  <p>KIT GICLEUR SOLEX VW 1300 SEDAN L<br/>74/83 CARB.30PICS-GASOLINA</p> <p>GAPR 117/GMLS 47/AVK/CATE<br/>120/T-2101-45/GASOLINA</p>  |
| <p><b>114.516/17</b></p>  <p>KIT GICLEUR SOLEX VW SEDAN<br/>BRASILIA1600 75/82 CARB.32PDSIT 2/3<br/>DUPL0-GASOLINA</p> <p>GAPR 155/CAR SOLEX 115/AVKB/GMLS<br/>52/T-2102-40/GASOLINA (DUPL0)</p> | <p><b>114.548/49</b></p>  <p>KIT GICLEUR SOLEX VW GOL1600 84/86<br/>CARB.32PDSIT 2/3DUPL0-GASOLINA</p> <p>GAPR 132/CAR SOLEX 70/AVKB/GMLS<br/>50/T-2102-40/GASOLINA (DUPL0)</p>         | <p><b>114.552/53</b></p>  <p>KIT GICLEUR SOLEX VW 1600 84/86<br/>CARB.32PDSIT 2/3 DUPL0-ÁLCOOL</p> <p>GAPR 157/CAR SOLEX 115/AVKB/GMLS<br/>60/T-2102-70/ÁLCOOL (DUPL0)</p>          | <p><b>114.556/57</b></p>  <p>KIT GICLEUR SOLEX VW GOL1300 80/81<br/>CARB.32PDSIT2/3 DUPL0-ÁLCOOL</p> <p>GAPR 140/CAR SOLEX 130/AVKB/GMLS<br/>57/T-2102-60/ÁLCOOL (DUPL0)</p>                     |
| <p><b>114.560/61</b></p>  <p>KIT GICLEUR SOLEX VW GOL1600 82/86<br/>CARB.32PDSIT 2/3DUPL0-ÁLCOOL</p> <p>GAPR 165/CAR SOLEX 130/AVKB/GMLS<br/>62/T-2102-55/ÁLCOOL (DUPL0)</p>                    | <p><b>114.562/63</b></p>  <p>KIT GICLEUR SOLEX VW KOMBI 1600 82/91<br/>CARB. 32PDSIT 2/3 DUPL0-GASOLINA</p> <p>GAPR 115/CAR SOLEX 130/AVKB/GMLS<br/>52/T-2102-40/GASOLINA (DUPL0)</p>  | <p><b>114.564/65</b></p>  <p>KIT GICLEUR SOLEX VW KOMBI 1600 82/91<br/>CARB. 32PDSIT 2/3 DUPL0-ÁLCOOL</p> <p>GAPR 157/CAR SOLEX 125/AVKB/GMLS<br/>62/T-2104-70/ÁLCOOL (DUPL0)</p>  | <p><b>114.570/71</b></p>  <p>KIT GICLEUR SOLEX VW KOMBI 1600 91/<br/>CARB. 32PDSIT 2/3 DUPL0-GASOLINA</p> <p>GAPR 117/CAR SOLEX 130/AG KOMBI<br/>CLIPPER/GMLS 50/T-2104-40/GASOLINA (DUPL0)</p> |
| <p><b>114.572/73</b></p>  <p>KIT GICLEUR SOLEX VW KOMBI 1600 91/<br/>CARB. 32PDSIT 2/3 DUPL0-ÁLCOOL</p> <p>GAPR 157/CAR SOLEX 125/AG KOMBI<br/>CLIPPER/GMLS 62/T-2108-35/ÁLCOOL (DUPL0)</p>     | <p><b>130.506</b></p>  <p>KIT GICLEUR SOLEX VW<br/>GOL/PARATI/SAVEIRO/VOYAGE 1.6 10/92<br/>CARB.BLFA-GASOLINA</p> <p>TUBO BLFA 12829/ML BLFA 150x57/AG<br/>BLFA/T-2109-60/GASOLINA</p> | <p><b>130.507</b></p>  <p>KIT GICLEUR SOLEX VW<br/>GOL/PARATI/SAVEIRO/VOYAGE 1.6 10/92<br/>CARB.BLFA-ÁLCOOL</p> <p>TUBO BLFA 12830/ML BLFA 140x80/AG<br/>BLFA/T-2115-40/ÁLCOOL</p> | <p><b>130.526</b></p>  <p>KIT GICLEUR SOLEX VW<br/>GOL/PARATI.6/SAVEIRO1.6/VOYAGE 89/91<br/>CARB.BLFA-ÁLCOOL</p> <p>TUBO BLFA 12826/ML BLFA 135x80/AG<br/>BLFA/T-2115-80/ÁLCOOL</p>             |
| <p><b>130.532</b></p>  <p>KIT GICLEUR SOLEX VW GOL<br/>/VOYAGE/SAVEIRO 1.6/PARATI89/91<br/>CARB.BLFA-GASOLINA</p> <p>TUBO BLFA 12824/ML BLFA 140x57/AG<br/>BLFA/T-2115-50/GASOLINA</p>          | <p><b>130.533</b></p>  <p>KIT GICLEUR SOLEX<br/>VWGOL/PARATI/SAVEIRO/VOYAGE 1.6 91/92<br/>CARB.BLFA-GASOLINA</p> <p>TUBO BLFA 12825/ML BLFA 140x55/AG<br/>BLFA/T-2103-85/GASOLINA</p>  | <p><b>170.510</b></p>  <p>KIT GICLEUR SOLEX VW S.QNT 1.8/G GTS/P<br/>GTS 1.8 91/92 2E7-GASOLINA</p> <p>GAPR 107-102/ML 2E7-3E 160x47/AG<br/>S-M/T-2108-35/GASOLINA</p>             | <p><b>170.521</b></p>  <p>KIT GICLEUR SOLEX VW SANTANA<br/>QUANTUM 1.8 91/92 CARB.2E7-ÁLCOOL</p> <p>GAPR 127-157/ML 2E7-3E 155x65/AG<br/>S-M/T-2108-60/ÁLCOOL</p>                               |













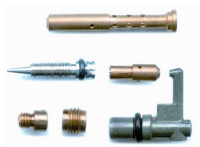
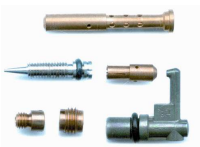
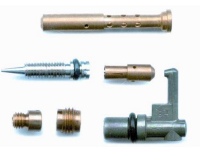
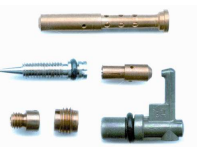







**125 KIT DE GICLEUR SOLEX - VW**

|  |   |   |  |
|--|---|---|--|
| <p><b>170.534-2</b></p>  <p>KIT GICLEUR SOLEX VW LOGUS/POINTER 1.8 10/92... CARB. 2ECE-GASOLINA<br/>GAPR 105-115/ML 2E7-3E 135x47/AG S-M/T-2108-35/GASOLINA</p> | <p><b>170.541</b></p>  <p>KIT GICLEUR SOLEX VW SANT QUANT/GOL GTS/CARB.2E7/PARATI GLS1.8 10/91 A 07/93-ÁLC<br/>GAPR 127-157/AG S-M/ML 2E7/3E 155x65/T-2108-60/ÁLCOOL</p> | <p><b>170.549</b></p>  <p>KIT GICLEUR SOLEX VW SANTANA/QUANTUM1.8 7/93... CARB.2ECE-ÁLCOOL<br/>GAPR 125-157/ML 2E7-3E 155x82/AG S-M/T-2108-35/ÁLCOOL</p>  | <p><b>175.509</b></p>  <p>KIT GICLEUR SOLEX VW SANTANA QUANTUM 1.8 11/89 A 09/91 CARB.2E7-ÁLCOOL<br/>GAPR 122-145/AG S-M/ML 2E7-3E 145x67/T-2111-150/ÁLCOOL</p> |
| <p><b>175.525</b></p>  <p>KIT GICLEUR SOLEX VW SANTANA QUANTUM1.8 89/91 CARB.2E7-GASOLINA<br/>GAPR 110-117/ML 2E7-3E 155x65/AG S-M/T-2108-35/GASOLINA</p>       | <p><b>175.526</b></p>  <p>KIT GICLEUR SOLEX VW GOL/PARATI GLS 1.8/VOYAGE GLS1.8 CARB.2E7 11/89 A 09/91-ÁLC<br/>GAPR 130-190/AG S-M/ML 2E7/3E 145x60/T-2104-70/ÁLCOOL</p> | <p><b>175.530</b></p>  <p>KIT GICLEUR SOLEX VW GOL GTS/PARATI 1.8 89/91 CARB.2E7-GASOLINA<br/>GAPR 110-135/ML 2E7-3E 155x47/AG S-M/T-2108-35/GASOLINA</p> | <p><b>175.554</b></p>  <p>KIT GICLEUR SOLEX VW SANTANA QUANTUM 2.0 88/89 CARB. 2E7-GASOLINA<br/>GAPR 110-115/ML 2E7-3E 150x50/AS S-M/T-2108-35/GASOLINA</p>     |
| <p><b>175.557</b></p>  <p>KIT GICLEUR SOLEX VW SANTANA QUANTUM2.0 88/89CARB.2E7-ÁLCOOL<br/>GAPR 140-177/ML 2E7-3E 135x65/AG S-M/T-2108-70/ÁLCOOL</p>           | <p><b>175.589</b></p>  <p>KIT GICLEUR SOLEX VW ST/PST/VI/P/Q/G-GTS 1.8 84/89 CARB 2E-GASOLINA<br/>GAPR 110-127/ML 2E7-3E 150x50/AG S-M/T-2108-35/GASOLINA</p>           | <p><b>175.594</b></p>  <p>KIT GICLEUR SOLEX VW SANT 88/89 - VOY/PAR/PST 1.8 2E7-ÁLCOOL<br/>GAPR 140-220/ML 2E7-3E 155x60/AG S-M/T-2108-70/ÁLCOOL</p>     | <p><b>175.597</b></p>  <p>KIT GICLEUR SOLEX VW SANTANA/QUANTUM1.8 84/89 CARB.2E7-ÁLCOOL<br/>GAPR 140-220/ML 2E7-3E 140x60/AG S-M/T-2108-70/ÁLCOOL</p>          |
| <p><b>176.502</b></p>  <p>KIT GICLEUR SOLEX VW SANTANA QUANTUM2.0 89/90 CARB.3E-ÁLCOOL<br/>GAPR 135-170/ML 2E7-3E 160x80/AG S-M/T-2108-70/ÁLCOOL</p>          | <p><b>176.515</b></p>  <p>KIT GICLEUR SOLEX VW SANTANA QUANTUM 2.0 11/90 A 09/91 CARB.3E-ÁLCOOL<br/>GAPR 137-152/AG S-M/ML 2E7/3E 160x80/T-2108-70/ÁLCOOL</p>          | <p><b>176.534</b></p>  <p>KIT GICLEUR SOLEX VW SANTANA QUANTUM 2.0 92/ CARB 3E-ÁLCOOL<br/>GAPR 140-152/ML 2E7-3E 160x80/AG S-M/T-2108-70/ÁLCOOL</p>     | <p><b>176.542</b></p>  <p>KIT GICLEUR SOLEX VW SANTANA QUANTUM 2.0 92/ CARB 3E-GASOLINA<br/>GAPR 112-107/ML 2E7-3E 145x57/AG S-M/T-2108-35/GASOLINA</p>       |
| <p><b>176.552</b></p>  <p>KIT GICLEUR SOLEX VW SANTANA /QUANTUM 2.0 10/92... CARB.3ECE-ÁLCOOL<br/>GAPR 132-147/ML 2E7-3E 160x82/AG S-M/T-2108-35/ÁLCOOL</p>   | <p><b>176.553</b></p>  <p>KIT GICLEUR SOLEX VW SANTANA.QUANTUM 2.0 9/93... CARB.3ECE-ÁLCOOL<br/>GAPR 132-147/ML 2E7-3E 140x80/AG S-M/T-2108-60/ÁLCOOL</p>              | <p><b>40.505</b></p>  <p>KIT GICLEUR SOLEX VW PASSAT/VOYAGE1500 74 35PDSIT-GASOLINA<br/>GAPR 145/CAR SOLEX 100/AG PASSAT/GMLS 55/T-2103-50/GASOLINA</p> | <p><b>40.595</b></p>  <p>KIT GICLEUR SOLEX VW PASSAT/VOYAGE1500 79/82 CARB.35PDSIT-ÁLCOOL<br/>GAPR 167/CAR SOLEX 60/AG PASSAT/GMLS 60/T-2103-50/ÁLCOOL</p>    |

**130 KIT DE GICLEUR WEBER - FIAT**



|   |   |   |   |
|---|---|---|---|
| <p><b>190.064</b></p>  <p>KIT GICLEUR WEBER FIAT 1.3 FIORINO/PANORAMA/UNO 83/88-ÁLCOOL<br/>GP.TLDZ B-2 150/GG.ML 65/RP.MP 140/T-2151-40.7°</p> | <p><b>190.068</b></p>  <p>KIT GICLEUR WEBER FIAT 1.3 PREMIO/OGGI 83-ÁLCOOL<br/>GP.TLDZ B-2 150/GP.ML 65/RP.MP 140/T-2151-40.7°</p> | <p><b>190.072</b></p>  <p>KIT GICLEUR WEBER FIAT UNO 1.3 85/89 TLDZ 190.072-GASOLINA<br/>GP.TLDZ F-86 122/GG.ML 45/RP.MP 185/T-T-2151-40.7°</p> | <p><b>190.076</b></p>  <p>KIT GICLEUR WEBER FIAT 1.3 UNO/ PREMIO 89/ TLDZ-ÁLCOOL<br/>GP.TLDZ B-3 140/GG.ML 55/RP.MP 160/T-2151-40.7°</p> |
|---|---|---|---|

**130 KIT DE GICLEUR WEBER - FIAT**

|  |   |   |   |
|--|---|---|---|
| <p><b>190.077</b></p>  <p>KIT GICLEUR WEBER FIAT 1.5 UNO/PRÊMIO/<br/>ELBA 10/91 À 12/92-ÁLCOOL</p> <p>TM F-50/GP.TLDZ 150/ML.TLDZF 50/RP.MP 180</p>   | <p><b>190.088</b></p>  <p>KIT GICLEUR WEBER FIAT 1.5 UNO/PICK<br/>UP/FIORINO À PARTIR 01/90-GASOLINA</p> <p>TM F-73/GP.TLDZ 125/GG.ML 55/RP.MP 175</p>   | <p><b>190.090</b></p>  <p>KIT GICLEUR WEBER FIAT 994CC UNO<br/>MILLE 90/94 TLDZ-GASOLINA</p> <p>GP.TLDZ F-73 130/GG.ML 47/RP.MP 190/T-2151-40.7°</p>  | <p><b>190.106</b></p>  <p>KIT GICLEUR WEBER FIAT 1.5 UNO<br/>CS/PRÊMIO/ ELBA À PARTIR<br/>JAN/93-GASOLINA</p> <p>TM F-73/GP.TLDZ 125/GG.ML.TLDZF 55/RP.MP 180</p>  |
| <p><b>460.103</b></p>  <p>KIT GICLEUR WEBER FIAT 1.5 UNO À<br/>PARTIR 11/86-ÁLCOOL</p> <p>TM F-22 F-28/GP.CHT 140 140/GPML.CHT 65<br/>50/CAR.CHT 205 150/AG.CHT/T-2151-50.7°</p>                  | <p><b>460.104</b></p>  <p>KIT GICLEUR WEBER FIAT 1.5 PRÊMIO À<br/>PARTIR DE 86-GASOLINA</p> <p>TM F-30 F-30/GP.CHT 115 107/GPML.CHT 60<br/>60/CAR.CHT 190 145/AG.CHT/T-2151-50.7°</p>                  | <p><b>460.109</b></p>  <p>KIT GICLEUR WEBER FIAT 1.5 PRÊMIO/<br/>ELBA À PARTIR DE 87-ÁLCOOL</p> <p>TM F-22 F-28/GP.CHT 140 140/GPML.CHT 60<br/>50/CAR.CHT210 140/AG.CHTÁLC/T-2151-60.7°</p>             | <p><b>460.110</b></p>  <p>KIT GICLEUR WEBER FIAT 1.5 PRÊMIO/<br/>ELBA À PARTIR DE 87-GASOLINA</p> <p>TM F-30 F-30/GP.CHT 110 115/GPML.CHT 50<br/>60/CAR.CHT 200 200/AG.CHT/T-2151-50.7°</p>                  |
| <p><b>460.252</b></p>  <p>KIT GICLEUR WEBER FIAT 1.5 PREMIO/<br/>ELBA 85/88-ÁLCOOL</p> <p>GP.CHT F-22 102 F-25L 130/GPML.CHT 47<br/>40/CAR.CHT 205 155/AG.CHT/T-2151-50.7°</p>                   | <p><b>460.306</b></p>  <p>KIT GICLEUR WEBER FIAT 1.5 UTILITÁRIOS<br/>89/91-ÁLCOOL</p> <p>GP.CHT F 42 107-F 44 125/GPML.CHT 55 60/CAR.CHT<br/>205 195/AG.CHT/T-2151-70.7°</p>                          | <p><b>460.318</b></p>  <p>KIT GICLEUR WEBER FIAT 1.5<br/>UTILITARIOS/COMP.BORDO<br/>12/89...-GASOLINA</p> <p>GP.CHT F-22 105 F-44 125/GPML.CHT 50 90/CAR.CHT<br/>180 220/AG.CHT/T-2151-45.7°</p>       | <p><b>460.349</b></p>  <p>KIT GICLEUR WEBER FIAT TEMPRA 2.0<br/>01/93-ÁLCOOL</p> <p>TM F-25L B-16/GP.CHT 140 160/GPML.CHT 57<br/>60/CAR.CHT 180 180/AG.CHT/T-2151-50.7°</p>                                 |
| <p><b>460.350</b></p>  <p>KIT GICLEUR WEBER FIAT TEMPRA 2.0 À<br/>PARTIR 01/93-GASOLINA</p> <p>TM F-22 B-15/GP.CHT 105 105/GPML.CHT 47<br/>45/CAR.CHT 200 175/AG.CHT/T-2151-50.7°</p>           | <p><b>460.352</b></p>  <p>KIT GICLEUR WEBER FIAT 994CC UNO<br/>MILLE 91-GASOLINA</p> <p>GP.CHT B-16 90 B-15 102/GPML.CHT 52 70/CAR.CHT<br/>210 205/AG.CHT/T-2151-40.7°</p>                           | <p><b>460.362</b></p>  <p>KIT GICLEUR WEBER FIAT TEMPRA 2.0C AR<br/>93-GASOLINA</p> <p>GP.CHT F-22 105 B-15 102/GPML.CHT 60 45/CAR.CHT<br/>175 185/AG.CHT/T-2151-50.7°</p>                            | <p><b>495.201</b></p>  <p>KIT GICLEUR WEBER FIAT UNO<br/>R/PREMIO/ELBA/PICK LX 89/91<br/>TLDF-ÁLCOOL</p> <p>GP.TLDZ F-74 132 F-25C 165/ML.TLDZF 60 60/RP.MP<br/>165 160/AG.TLDZ/T-2154-45</p>              |
| <p><b>495.206</b></p>  <p>KIT GICLEUR WEBER FIAT UNO R/<br/>PREMIO/ELBA/PICK LX 89/91<br/>TLDF-GASOLINA</p> <p>GP.TLDZ F-74 115 F-50 117/ML.TLDZF 47 60/RP.MP<br/>180 170/AG.TLDZ/T-2154-45</p> | <p><b>495.209</b></p>  <p>KIT GICLEUR WEBER FIAT UNO R<br/>1.6/PRÊMIO/ELBA DE OUT/91 À<br/>DEZ/91-ÁLCOOL</p> <p>TM F-74 F-25C/GP.TLDZ 132 165/ML.TLDZF 62<br/>60/RP.MP 165 160/AG.TLDZ/T-2154-45</p> | <p><b>495.210</b></p>  <p>KIT GICLEUR WEBER FIAT UNO R<br/>1.6/PRÊMIO/ELBA DE OUT/91 À<br/>DEZ/91-GASOLINA</p> <p>TM F-74 F-50/GP.TLDZ 117 117/ML.TLDZF 52<br/>60/RP.MP 175 170/AG.TLDZ/T-2154-45</p> | <p><b>495.212</b></p>  <p>KIT GICLEUR WEBER FIAT 1.6 UNO<br/>R/PRÊM/ELBA/PICK LX À PARTIR 10/91 À<br/>12/91-GAS</p> <p>TM F-74 F-50/GP.TLDZ 117 117/ML.TLDZF 52<br/>60/RP.MP 175 170/AG.TLDZ/T-2154-45</p> |
| <p><b>495.219</b></p>  <p>KIT GICLEUR WEBER FIAT 1.6 UNO/PRÊMIO<br/>01/93-ÁLCOOL</p> <p>TM F-74 F-25C/GP.TLDZ 132 165/ML.TLDZF 62<br/>60/RP.MP 165 160/AG.TLDZ/T-2154-45</p>                    |   |   |   |

**135 KIT DE GICLEUR WEBER - FORD**

**135 KIT DE GICLEUR WEBER - FORD**

|  |   |   |   |
|--|---|---|---|
| <p><b>228.109</b></p>  <p>KIT GICLEUR WEBER FORD CORCEL II/BL 1.4 80/83 DFV-GASOLINA</p> <p>13068 310.300/GP.DFV 135/ML.DFV 65</p>  | <p><b>228.113</b></p>  <p>KIT GICLEUR WEBER FORD CORCEL 2/BELINA 1.4 80/82 DFV+G463-ÁLCOOL</p> <p>13068 310.300/GP.DFV 165/ML.DFV 70</p>   | <p><b>460.003</b></p>  <p>KIT GICLEUR WEBER FORD CORCEL/BELINA/ESCORT 1.6/PAMPA 1.6 07/83 À 08/84-ÁLCOOL</p> <p>TM F-22 F-25L/GP.CHT 152 160/GPML.CHT 75 65/CAR.CHT 175 120/AG.CHT/T-2151-50.7°</p> | <p><b>460.013</b></p>  <p>KIT GICLEUR WEBER FORD CORCEL 2 /BEL/DEL/ESCORT/PAM 1.6 83/84-GASOLINA</p> <p>GP.CHT F-36 125 F-28 90/GPML.CHT 62 50/CAR.CHT 195 85/AG.CHT/T-2151-40.7°</p>  |
| <p><b>460.015</b></p>  <p>KIT GICLEUR WEBER FORD ESCORT XR3 1.6 JUL/83 À DEZ/85-ÁLCOOL</p> <p>TM F-22 F-28/GP.CHT 155 190/GPML 80 60/CAR.CHT 175 160/AG.CHT/T-2151-50.7°</p>          | <p><b>460.027</b></p>  <p>KIT GICLEUR WEBER FORD CORCEL II/BELINA/ESCORT 1.6 SET/84 À SET/85-ÁLCOOL</p> <p>TM F-25L F-28/GP.CHT 122 127/GPML.CHT 75 55/CAR.CHT 155 150/AG.CHT/T-2151-40.7°</p> | <p><b>460.028</b></p>  <p>KIT GICLEUR WEBER FORD ESCORT 1.6 C/AR 86/...-ÁLCOOL</p> <p>GP.CHT F-28 155 F-28 195/GPML.CHT 80 60/CAR.CHT 175 140/AG.CHT/T-2151-50.7°</p>                               | <p><b>460.032</b></p>  <p>KIT GICLEUR WEBER FORD CORCEL/BELINA/ESCORT 1.6 À PARTIR 86-ÁLCOOL</p> <p>TM F-28 F-39/GP.CHT 115 122/GPML.CHT 85 60/CAR.CHT 135 155/AG.CHT/T-2151-40.7°</p> |
| <p><b>460.034</b></p>  <p>KIT GICLEUR WEBER FORD CORCEL 2/BEL/DEL/ESCORT/VERONA 1.6 90-GASOLINA</p> <p>GP.CHT F-30 107 F-28 95/GPML.CHT 65 70/CAR.CHT 190 150/AG.CHT/T-2151-40.7°</p> | <p><b>460.043</b></p>  <p>KIT GICLEUR WEBER FORD CORCEL 2 /BELINA DR/ESC/PAMPA 1.6 85-ÁLCOOL</p> <p>GP.CHT F-28 115 F-39 122/GPML.CHT 60 60/CAR.CHT 135 155/AG.CHT/T-2151-40.7°</p>            | <p><b>460.270</b></p>  <p>KIT GICLEUR WEBER FORD ESCORT 1.0 6/93-GASOLINA</p> <p>GP.CHT B-17 105 F-22 115/GPML.CHT 52 52/CAR.CHT 170 120/AG.CHT/T-2151-35.7°</p>                                    |   |

**140 KIT DE GICLEUR WEBER - GM**

|  |   |  |   |
|--|---|--|---|
| <p><b>190.001</b></p>  <p>KIT GICLEUR WEBER GM MONZA 1.6 À PARTIR 82-GASOLINA</p> <p>TM B-8/GP.TLDZ 142/GP.ML 50/RP.MP 185/T-2151-45.7°</p> | <p><b>190.003</b></p>  <p>KIT GICLEUR WEBER GM MONZA 1.6 À PARTIR 82-ÁLCOOL</p> <p>TM B-10/GP.TLDZ 175/GP.ML 60/RP.MP 145/T-2151-55.7°</p>                     | <p><b>190.005</b></p>  <p>KIT GICLEUR WEBER GM MONZA 1.8 ATÉ 08/85-ÁLCOOL</p> <p>TM B-4/GP.TLDZ 180/GG.ML 50/RP.MP 125/T-2151-50.7°</p>                              | <p><b>228.032</b></p>  <p>KIT GICLEUR WEBER GM OPALA 4CIL. 75/83 DFV-GASOLINA</p> <p>13068 310.300/GP.DFV 29/ML.DFV 12</p> |
| <p><b>228.047</b></p>  <p>KIT GICLEUR WEBER GM CHEVETTE 1.6 77/81 DFV-GASOLINA</p> <p>13069 306300/GP.DFV 25/ML.DFV 12</p>                  | <p><b>460.402</b></p>  <p>KIT GICLEUR WEBER GM CHEVETTE 1.6 87-GASOLINA</p> <p>GP.CHT F-43 115 F-36 117/GPML.CHT 52 62/CAR.CHT 190 155/AG.CHT/T-2151-40.7°</p> | <p><b>460.412</b></p>  <p>KIT GICLEUR WEBER GM CHEVETTE 1.6 12/89...-ÁLCOOL</p> <p>GP.CHT F-25L 132 F-24L 162/GPML.CHT 57 62/CAR.CHT 150 155/AG.CHT/T-2151-60.7°</p> |   |

**145 KIT DE GICLEUR WEBER - VW**

|  |   |  |   |
|--|---|--|---|
| <p><b>450.302</b></p>  <p>KIT GICLEUR WEBER VW PASSAT 1.6 81/82-ÁLCOOL</p> <p>GP.MP B-3 135 B-6 160/GP.ML 50 65/RP.MP 170 180/AG.MP/T-2155-70</p> | <p><b>450.310</b></p>  <p>KIT GICLEUR WEBER VW PASSAT/PARATI/GOL/VOYAGE 1.6 81/833-ÁLCOOL</p> <p>GP.MP B-3 125 B-4 160/GG.ML 50 60/RP.MP 160 160/AG.MP/T-2155-70</p> | <p><b>450.350</b></p>  <p>KIT GICLEUR WEBER VW PASSAT/PARATI/GOL/VOYAGE 1.6 1-84/5-84-GAS</p> <p>GP.MP B-11 105 B-12 112/GG.ML 52 57/RP.MP 195 120/AG.MP/T-2155-45</p> | <p><b>450.351</b></p>  <p>KIT GICLEUR WEBER VW PASSAT/PARATI/VOYAGE 1.6 01/84 À 11/84-ÁLCOOL</p> <p>TM B-3 B-4/GP.MP 127 150/GG.ML 57 70/RP.MP 160 170/AG.MP/T-2155-65</p> |
|--|---|--|---|



**145 KIT DE GICLEUR WEBER - VW**

|  |   |  |   |
|--|---|--|---|
| <p><b>450.355</b></p> <p>KIT GICLEUR WEBER VW<br/>PASSAT/PARATI/GOL/VOYAGE 1.6<br/>VAC.84/85-ÁLCOOL<br/>GP.MP B-3 127 B-4 155/GG.ML 55 62/RP.MP 170<br/>170/AG.MP/T-2155-65</p>                  | <p><b>450.400</b></p> <p>KIT GICLEUR WEBER VW PST/P/G/V 1.6<br/>VAC.85/88-GASOLINA<br/>GP.MP B-11 105 B-12 112/GG.ML 50 52/RP.MP 185<br/>120/AG.MP/T-2155-50</p>                                  | <p><b>450.401</b></p> <p>KIT GICLEUR WEBER VW<br/>PASSAT/PARATI/GOL/VOYAGE 1.6<br/>VC.85/88-ÁLCOOL<br/>GP.MP B-6 135 B-4 132/GG.ML 52 45/RP.MP 195<br/>190/AG.MP/T-2155-65</p>                     | <p><b>450.406</b></p> <p>KIT GICLEUR WEBER VW<br/>PASSAT/PARATI/VOYAGE 1.6 12/84 À<br/>01/88-GASOLINA<br/>TM B-11 B-12/GP.MP 105 112/GG.ML 52 57/RP.MP 195<br/>120/AG.MP/T-2155-45</p>            |
| <p><b>450.407</b></p> <p>KIT GICLEUR WEBER VW<br/>PASSAT/PARATI/VOYAGE 1.6 DEZ/84 À<br/>JUN/85-ÁLCOOL<br/>TM B-3 B-4/GP.MP 127 155/GG.ML 55 62/RP.MP 170<br/>170/AG.MP/T-2155-65</p>             | <p><b>460.260</b></p> <p>KIT GICLEUR WEBER VW<br/>GOL/PARATI/VOYAGE/SAV.1.6 AE 600<br/>89/91-GASOLINA<br/>GP.CHT F-25L 105 F-28 102/GP.ML.CHT 45<br/>70/CAR.CHT 160 155/AG.CHT/T-T-2151-40.7°</p> | <p><b>460.261</b></p> <p>KIT GICLEUR WEBER VW<br/>GOL/PARATI/VOYAGE/SAV.1.6 AE 600<br/>89/91-ÁLCOOL<br/>GP.CHT F-28 115 F-39 102/GPML.CHT 60 60/CAR.CHT<br/>135 155/AG.CHT/T-2151-40.7°</p>        | <p><b>460.262</b></p> <p>KIT GICLEUR WEBER VW LOGUS 1.6 À<br/>PARTIR 01/93-GASOLINA<br/>TM B-17 F-39/GP.CHT 110 110/GPML.CHT 52<br/>52/CAR.CHT 200 100/AG.CHT/T-2151-40.7°</p>                    |
| <p><b>460.263</b></p> <p>KIT GICLEUR WEBER VW LOGUS 1.6 À<br/>PARTIR 01/93-ÁLCOOL<br/>TM B-20 F-24L/GP.CHT 132 130/GPML.CHT 60<br/>60/CAR.CHT 160 175/AG.CHT/T-2151-40.7°</p>                    | <p><b>460.264</b></p> <p>KIT GICLEUR WEBER VW<br/>GOL/PARATI/VOYAGE/SAV.1.6 AE 600<br/>91-GASOLINA<br/>GP.CHT B-17 100 F-22 100/GPML.CHT 50 52/CAR.CHT<br/>150 100/AG.CHT/T-2151-40.7°</p>        | <p><b>460.265</b></p> <p>KIT GICLEUR WEBER VW<br/>GOL/PARATI/VOYAGE/SAV.1.6 AE 600<br/>91-ÁLCOOL<br/>GP.CHT B-17 122 F-24L 117/GPML.CHT 60<br/>62/CAR.CHT 155 160/AG.CHT/T-2151-40.7°</p>          | <p><b>460.266</b></p> <p>KIT GICLEUR WEBER VW GOL 1000 AE<br/>92-GASOLINA<br/>GP.CHT B-26 97 F-22 95/GPML.CHT 50 52/CAR.CHT<br/>150 120/AG.CHT/T-2151-35.7°</p>                                   |
| <p><b>460.272</b></p> <p>KIT GICLEUR WEBER VW GOL 1.0<br/>93(LONG)AE 1000-GASOLINA<br/>GP.CHT B-17 105 F-22 115/GPML.CHT 52 52/CAR.CHT<br/>175 120/AG.CHT/T-2154-35</p>                          | <p><b>495.001</b></p> <p>KIT GICLEUR WEBER VW<br/>GOL/PARATI/VOYAGE/SAV.1.6 AE 600<br/>89/TLDZ-ÁLCOOL<br/>GP.TLDZ B-1 150 B-4 160/ML.TLDZGR 55 60/RP.MP<br/>110 135/AG.TLDZ/T-2154-60</p>         | <p><b>495.002</b></p> <p>KIT GICLEUR WEBER VW<br/>VOYAGE/PARATI/GOL/SAVEIRO 1.6 À<br/>PARTIR DEZ/89-GASOLINA<br/>TM B-3 B-5/GP.TLDZ 112 130/ML.TLDZG 47 60/RP.MP<br/>150 165/AG.TLDZ/T-2154-45</p> | <p><b>495.018</b></p> <p>KIT GICLEUR WEBER VW<br/>VOYAGE/PARATI/GOL/SAVEIRO 1.8 09/89 À<br/>01/91-GASOLINA<br/>TM B-3 B-5/GP.TLDZ 117 130/ML.TLDZF 52 50/RP.MP<br/>130 130/AG.TLDZ/T-2154-40</p>  |
| <p><b>495.021</b></p> <p>KIT GICLEUR WEBER VW G/P/V 1.8 AP 91/92<br/>TLDZ-ÁLCOOL<br/>GP.TLDZ F-66 145 B-4 157/ML.TLDZF 57 70/RP.MP<br/>165 110/AG.TLDZ/T-2154-55</p>                             | <p><b>495.025</b></p> <p>KIT GICLEUR WEBER VW<br/>VOYAGE/PARATI/GOL/SAVEIRO 1.8 À<br/>PARTIR OUT/92-ÁLCOOL<br/>TM B-4 F-66/GP.TLDZ 142 165/ML.TLDZF 61<br/>70/RP.MP 165 110/AG.TLDZ/T-2154-55</p> | <p><b>495.028</b></p> <p>KIT GICLEUR WEBER VW<br/>GOL/PARATI/VOYAGE/SAV.1.8 91/92<br/>TLDZ-GASOLINA<br/>GP.TLDZ F-66 120 F-24C 135/ML.TLDZF 52 55/RP.MP<br/>185 125/AG.TLDZ/T-2154-35</p>          | <p><b>495.029</b></p> <p>KIT GICLEUR WEBER VW<br/>VOYAGE/PARATI/GOL/SAVEIRO 1.6 À<br/>PARTIR 05/93-ÁLCOOL<br/>TM F-66 B-12/GP.TLDZ 142 165/ML.TLDZF 57<br/>80/RP.MP 165 110/AG.TLDZ/T-2154-55</p> |
| <p><b>495.042</b></p> <p>KIT GICLEUR WEBER VW<br/>VOYAGE/PARATI/GOL/SAVEIRO 1.8 02/91 À<br/>09/91-GASOLINA<br/>TM B-3 B-5/GP.TLDZ 120 130/ML.TLDZF 47 50/RP.MP<br/>135 130/AG.TLDZ/T-2154-40</p> | <p><b>495.400</b></p> <p>KIT GICLEUR WEBER VW<br/>VOYAGE/PARATI/GOL/SAV.1.8 LONG 92<br/>TLDE-GASOLINA<br/>GP.TLDZ F-66 125 F-24C 135/ML.TLDZF 52 65/RP.MP<br/>145 135/AG.TLDZ/T-2154-45</p>       | <p><b>495.401</b></p> <p>KIT GICLEUR WEBER VW<br/>VOYAGE/PARATI/GOL/SAV.1.8 LONG TLDZ<br/>93-ÁLCOOL<br/>GP.TLDZ F-66 142 B-12 165/ML.TLDZF 61 70/RP.MP<br/>155 110/AG.TLDZ/T-2154-60</p>           | <p><b>495.402</b></p> <p>KIT GICLEUR WEBER VW LOGOS 1.8 93/<br/>(TRANSVERSAL) TLDE-GASOLINA<br/>GP.TLDZ F-66 127 F-24C 122/ML.TLDZF 50 65/RP.MP<br/>180 150/AG.TLDZ/T-2154-40</p>                 |

**145 KIT DE GICLEUR WEBER - VW**

|  |  |  |  |
|--|--|--|--|
| <p><b>495.403</b></p>  <p>KIT GICLEUR WEBER VW LOGOS 1.8 93/<br/>(TRANSVERSAL) TLDE-ÁLCOOL<br/>GP.TLDZ F-66 140 B-12 157/ML.TLDZF 57 70/RP.MP<br/>165 110/AG.TLDZ/T-2154-60</p> |  |  |  |
|--|--|--|--|

**150 DIAFRAGMA**

|  |   |   |   |
|--|---|---|---|
| <p><b>T-001</b></p>  <p>DIAF. DUPLO - JEEP, PICK-UP, RURAL, F-75<br/>MOTOR 2500 4CC GASOLINA - SOLEX 40-EIS<br/>18402</p>         | <p><b>T-002</b></p>  <p>DIAF. SIMPLES - CHEVETTE, HATCH,<br/>MARAJÓ, KOMBI 1.5- SOLEX 35-PDSI /<br/>SOLEX 30-PIC<br/>40174</p>   | <p><b>T-002D</b></p>  <p>DIAF. DUPLO - CHEVETTE, HATCH, MARAJÓ,<br/>KOMBI 1.5- SOLEX 35-PDSI / SOLEX 30-PIC<br/>40174</p> | <p><b>T-003</b></p>  <p>DIAF. MOLDADO DUPLO - CHEVETTE,<br/>HATCH, MARAJÓ, CHEVY 500 1.6 - SOLEX<br/>35-PDSI<br/>40175</p> |
| <p><b>T-004</b></p>  <p>DIAF. DUPLO - ALFA ROMEOU, CHEVETTE 1.4,<br/>OPALA 2500 4CC, CORCEL - SOLEX 34-SEIE<br/>50072</p>        | <p><b>T-005</b></p>  <p>DIAF. DUPLO - ALFA ROMEOU, CHEVETTE 1.4,<br/>OPALA 2500 4CC, CORCEL - SOLEX 34-SEIE<br/>54074</p>       | <p><b>T-006</b></p>  <p>DIAF. MOLDADO DUPLO - OPALA, CARAVAN,<br/>PICK-UP 2500 4CC - SOLEX 34-SEIE<br/>54078</p>         | <p><b>T-007</b></p>  <p>DIAF. MOLDADO DUPLO - OPALA, CARAVAN,<br/>PICK-UP, VERANEIO - SOLEX 34-SEIE<br/>54079</p>         |
| <p><b>T-008</b></p>  <p>DIAF. SIMPLES - FIAT 147 1050 E 1300 -<br/>SOLEX 32-DIS-1 / SOLEX 32-DIS-3<br/>70007</p>                | <p><b>T-008D</b></p>  <p>DIAF. DUPLO - FIAT 147 1050 E 1300 -<br/>SOLEX 32-DIS-1 / SOLEX 32-DIS-3<br/>70007</p>                | <p><b>T-009</b></p>  <p>DIAF. MOLDADO SIMPLES - FIAT 147 1300<br/>ÁLCOOL TODOS 06/79 - SOLEX 32-DIS-2<br/>70072</p>     | <p><b>T-009D</b></p>  <p>DIAF. MOLDADO DUPLO - FIAT 147 1300<br/>ÁLCOOL TODOS 06/79 - SOLEX 32-DIS-2<br/>70072</p>       |
| <p><b>T-010</b></p>  <p>DIAF. SIMPLES - VW FUSCA 1.3 1.5 1.6,<br/>PASSAT 1.5 - SOLEX 30-PIC / SOLEX<br/>35-PDSIT<br/>112093</p> | <p><b>T-010D</b></p>  <p>DIAF. DUPLO - VW FUSCA 1.3 1.5 1.6,<br/>PASSAT 1.5 - SOLEX 30-PIC / SOLEX<br/>35-PDSIT<br/>112093</p> | <p><b>T-011</b></p>  <p>DIAF. MOLDADO SIMPLES - VW SEDAN 1300<br/>GASOLINA 10/74 À 12/83 - SOLEX 30-PICS<br/>112101</p> | <p><b>T-011D</b></p>  <p>DIAF. MOLDADO DUPLO - VW SEDAN 1300<br/>GASOLINA 10/74 À 12/83 - SOLEX 30-PICS<br/>112101</p>   |
| <p><b>T-012</b></p>  <p>DIAF. MOLDADO SIMPLES - PASSAT,<br/>VOYAGE 1500 ÁLC 09/79 À 10/82 - SOLEX<br/>35-PDSI<br/>114076</p>    | <p><b>T-012D</b></p>  <p>DIAF. MOLDADO DUPLO - PASSAT, VOYAGE<br/>1500 ÁLC 09/79 À 10/82 - SOLEX 35-PDSI<br/>114076</p>        | <p><b>T-013</b></p>  <p>DIAF. SIMPLES - SEDAN 1600 ÁLCOOL,<br/>KOMBI 1600 - SOLEX 32-PDSIT/2<br/>114077</p>             | <p><b>T-013D</b></p>  <p>DIAF. DUPLO - SEDAN 1600 ÁLCOOL,<br/>KOMBI 1600 - SOLEX 32-PDSIT/2<br/>114077</p>               |

150 DIAFRAGMA

|  |   |  |   |
|--|---|--|---|
| <p><b>T-014</b></p>  <p>DIAF.SIMPLES - BRASILIA, SEDAN 1.6, KOMBI 1.6, GOL 1.3 AR - SOLEX 32-PDSIT/2/3</p> <p>114093</p>    | <p><b>T-014D</b></p>  <p>DIAF.DUPL0 - BRASILIA 1.3, SEDAN 1.6, KOMBI 1.6, GOL 1.3 AR - SOLEX 32-PDSIT/2/3</p> <p>114093</p>    | <p><b>T-015</b></p>  <p>DIAF.MOLDADO SIMPLES - VW SEDAN 1600, GOL, VOYAGE, PARATI 1.6 - SOLEX 31-PICT</p> <p>117076</p>      | <p><b>T-015D</b></p>  <p>DIAF.MOLDADO DUPL0 - VW SEDAN 1600, GOL, VOYAGE, PARATI 1.6 - SOLEX 31-PICT</p> <p>117076</p>         |
| <p><b>T-016</b></p>  <p>DIAF.MOLDADO DUPL0 - ESCORT 1.6, MONZA 1.6 1.8 - 30/34-BLFA / SOLEX 35-ALFA1</p> <p>130007</p>      | <p><b>T-017</b></p>  <p>DIAF. DUPL0 - GOL, VOYAGE, PARATI, SAVEIRO 1.6 - SOLEX 30/34-BLFA</p> <p>130029</p>                    | <p><b>T-018</b></p>  <p>DIAF. DUPL0 - MONZA 1.6 GASOLINA DE 01/82 - SOLEX 35-ALFA-1</p> <p>160077</p>                        | <p><b>T-019</b></p>  <p>DIAF.MOLDADO DUPL0 - GOL 1.8, SANTANA 1.8, MONZA 1.8, ESCORT 1.8 - SOLEX 2E7</p> <p>174095</p>         |
| <p><b>T-020</b></p>  <p>DIAF.DUPL0 - SANTANA 1.8, GOL, ESCORT XR3, VERSAILLES 1.8, CHEVETTE - SOLEX 2ECE</p> <p>174098</p> | <p><b>T-021</b></p>  <p>DIAF.MOLDADO DUPL0 - SANTANA 1.8, ESCORT XR3, VERSAILLES 1.8 - SOLEX 2ECE</p> <p>174099</p>           | <p><b>T-022</b></p>  <p>DIAF.MOLDADO SIMPLES - GOL 1.8, SANTANA 1.8, MONZA 1.8, ESCORT 1.8 - SOLEX 2E7</p> <p>175093</p>    | <p><b>T-023</b></p>  <p>DIAF.MOLDADO DUPL0 - OPALA 6CC, CARAVAN 6CC, MONZA 2.0 - SOLEX 3ECE</p> <p>176093</p>                 |
| <p><b>T-024</b></p>  <p>DIAF.DUPL0 - SANTANA 2.0, VERSAILLES 2.0, MONZA 2.0, OPALA - DUPL0 SOLEX 3E</p> <p>176093</p>     | <p><b>T-025</b></p>  <p>DIAF. MOLDADO DUPL0 - CAMINHÃO 6 CIL. ÁLCOOL DE 01/1985 - SOLEX 40-DEIS</p> <p>186040</p>            | <p><b>T-026</b></p>  <p>DIAF.DUPL0 - OPALA, CARAVAN, PICK-UP 2500 4, JEEP, RURAL, F-1000 - SOLEX 40-DEIS</p> <p>186076</p> | <p><b>T-027</b></p>  <p>DIAF.SIMPLES - PASSAT, GOL, PARATI, CHEVETTE 1.4, UNO 1.5R - WEBER DUPL0 450</p> <p>401.306.02</p>   |
| <p><b>T-027D</b></p>  <p>DIAF.DUPL0 - PASSAT, GOL, PARATI, CHEVETTE 1.4, UNO 1.5R - WEBER DUPL0 450</p> <p>401.306.02</p> | <p><b>T-028</b></p>  <p>DIAF.SIMPLES - FIAT 147, FIORINO, FIAT 1.3, MONZA 1.6 1.8 - WEBER SIMPLES 190</p> <p>401.449.02</p>  | <p><b>T-028D</b></p>  <p>DIAF.DUPL0 - FIAT 147, FIORINO, FIAT 1.3, MONZA 1.6 1.8 - WEBER SIMPLES 190</p> <p>401.449.02</p> | <p><b>T-029</b></p>  <p>DIAF.SIMPLES - PASSAT TS 1.6, GOL, VOYAGE 1.6 - WEBER DUPL0 450</p> <p>401.601.02</p>                |
| <p><b>T-029D</b></p>  <p>DIAF.DUPL0 - PASSAT TS 1.6, GOL, VOYAGE 1.6 - WEBER DUPL0 450</p> <p>401.601.02</p>              | <p><b>T-030</b></p>  <p>DIAF.MOLDADO - GOL,PARATI/CORCEL,DEL REY,ESCORT,VERONA - CHT 460/TLDF-TLDZ 495</p> <p>401.733.02</p> | <p><b>T-031</b></p>  <p>DIAF. MOLDADO SIMPLES/JUNTA - FIAT TEMPRA 2.0 - 34 DMTF 460</p> <p>403.588.02</p>                  | <p><b>T-032</b></p>  <p>DIAF.MOLDADO - PASSAT 1.6, GOL 1.6, PARATI, CHEVETTE 1.4 1.6 - WEBER DUPL0 450</p> <p>403.621.02</p> |



150 DIAFRAGMA

|  |   |   |  |
|--|---|---|--|
| <p><b>T-033</b></p>  <p>DIAF. MOLDADO - PASSAT, GOL, PARATI, VOYAGE 1.6 - WEBER DUPLO 450</p> <p>403.622.02</p>                 | <p><b>T-034</b></p>  <p>DIAF. MOLDADO - FIAT, UNO R, PRÊMIO, ELBA, PICK-UP LX 1.6 - 30/32 TLDF 495</p> <p>403.623.02</p>     | <p><b>T-035</b></p>  <p>DIAF. MOLDADO - SANTANA 1.8, GOL 1.8, LOGUS 1.8 ÁLCOOL - TLDZ 495 / TLDE 495</p> <p>603.624.02</p>  | <p><b>T-036</b></p>  <p>DIAF. MOLDADO - GOL, PARATI, VOYAGE, SAVEIRO 1.6 - 30/32 TLDZ 495</p> <p>403.625.02</p>                 |
| <p><b>T-037</b></p>  <p>DIAF. MOLDADO - FIAT 147, UNO 1.0 1.3 1.5, MONZA 1.6 1.8 - WEBER SIMPLES 190</p> <p>403.658.02</p>      | <p><b>T-038</b></p>  <p>DIAF. MOLDADO SIMPLES/JUNTA - FIAT TEMPRA 2.0 - 32/34 DMTF</p> <p>403.706.02</p>                     | <p><b>T-039</b></p>  <p>DIAF. MOLDADO SIMPLES/JUNTA - SAMARA TODOS / LAIKA, NIVA - LADA RUSSO</p> <p>210807360</p>          | <p><b>T-040</b></p>  <p>DIAF. MOLDADO SIMPLES/JUNTA - PASSAT TS 1.6 GASOLINA - SOLEX IMPORTADO</p> <p>100103</p>                |
| <p><b>T-048</b></p>  <p>DIAF. DUPLO V W 1200 - VW 1200 - SOLEX 11098</p> <p>11093</p>  | <p><b>T-049</b></p>  <p>DIAF. DUPLO LAIKA/NIVA - LAIKA, NIVA ATÉ 1992 - LADA RUSSO</p> <p>210107367</p>                     | <p><b>T-050</b></p>  <p>MEMBRANA DA BOMBA LAIKA/NIVA/SAMARA - LAIKA, NIVA, SAMARA - LADA RUSSO</p> <p>210106140</p>        | <p><b>T-051</b></p>  <p>DIAF. VÁLV. MÁX. REPARO S/BASE - GOL, SANTANA 1.8 - 2.0, ESCORT 1.8 - SOLEX 2E7 / 3E</p> <p>2044</p>   |
| <p><b>T-052-2E</b></p>  <p>DIAF. VÁLV. MÁX. C. BASE - GOL 1.8, SANTANA 1.8, MONZA 1.8, ESCORT 1.8 - SOLEX 2E7</p> <p>2067</p> | <p><b>T-052-3E</b></p>  <p>DIAF. VÁLV. MÁX. C. BASE - GOL, SANTANA 1.8 - 2.0, ESCORT 1.8 - SOLEX 2E7 / 3E</p> <p>3048</p>  | <p><b>T-053</b></p>  <p>DIAF. VÁLV. MÁX. REPARO S/BASE - OPALA 4CC - SOLEX 34 SEIE / 40-EIS / 40-DEIS</p> <p>3450</p>     | <p><b>T-054</b></p>  <p>DIAF. VÁLV. MÁX. C. BASE - OPALA 4CC - SOLEX 34 SEIE / SOLEX 40-EIS / SOLEX 40-DEIS</p> <p>3458</p>   |
| <p><b>T-056</b></p>  <p>DIAF. VÁLVULA MÁXIMA DUPLO - GOL 1.300 A AR, GASOLINA - SOLEX 30-PIC-2</p> <p>112109</p>              | <p><b>T-057</b></p>  <p>DIAF. VÁLV. MÁX. C. BASE - GOL 1.6, ESCORT CHT 1.6, MONZA 1.8 - SOLEX 30/34-BLFA</p> <p>130210</p> | <p><b>T-058</b></p>  <p>DIAF. VÁLV. MÁX. - FIAT 147, UNO, PREMIO, ELBA, MONZA 1.6 1.8 - SOLEX 35-ALFA-1</p> <p>160052</p> | <p><b>T-059</b></p>  <p>DIAF. VÁLV. MÁX. - GOL, SANTANA, ESCORT, CORCEL, UNO - CHT 460 / 495-TLDZ-TLDF-TLDE</p> <p>402253</p> |
| <p><b>T-061</b></p>  <p>DIAF. DESAFOGADOR MOLDADO SIMPLES - CHEVETTE, HATCH, MARAJÓ, - SOLEX 35-PDSI</p> <p>40131</p>         | <p><b>T-062</b></p>  <p>DIAF. DESAFOGADOR MOLDADO SIMPLES - PASSAT, VOYAGE 1500 GASOLINA - SOLEX PDSIT</p> <p>40133</p>    | <p><b>T-063</b></p>  <p>DIAF. DESAFOGADOR SIMPLES/ESQUERDO - L. ESQ. TODOS VW 1600 - SOLEX 32-PDSIT</p> <p>114203</p>     | <p><b>T-064</b></p>  <p>DIAF. DESAFOGADOR SIMPLES/DIREITO - L. DIR. TODOS VW 1600 - SOLEX 32-PDSIT</p> <p>114204</p>          |

**150 DIAFRAGMA**

























|  |   |   |   |
|--|---|---|---|
| <p><b>T-066</b></p>  <p>DIAF. DESAFOGADOR MOLDADO SIMPLES - MONZA 1.6 GAS. DE 01/82 - SOLEX 35 -ALFA-1<br/>160133</p> | <p><b>T-067</b></p>  <p>DIAF. DESAFOGADOR MOLDADO SIMPLES - MONZA 1.8 FIAT 147, UNO - SOLEX 35-ALFA-1<br/>160331</p> | <p><b>T-087</b></p>  <p>DIAF. MOLDADO - MAVERICK GALAXIE V8 - F2</p>            | <p><b>T-091</b></p>  <p>DIAF. MOLDADO</p>                                      |
| <p><b>T-125</b></p>  <p>DIAF. ACEL. PLANO DUPLO WEBER 40 PINO BAIXO<br/>204125</p>                                    | <p><b>T-126</b></p>  <p>DIAF. ACEL. PLANO DUPLO WEBER 40 PINO ALTO<br/>204126</p>                                    | <p><b>T-990</b></p>  <p>DIAF. ACEL. PRÉ-FORMADO SIMPLES/JUNTA 2E<br/>175093</p> | <p><b>T-991D</b></p>  <p>DIAF. ACEL. PRÉ-FORMADO DUPLO BRASILIA<br/>114095</p> |

**155 PISTÃO**

|   |  |  |   |
|---|--|--|---|
| <p><b>T-4262</b></p>  <p>PISTÃO INJETOR GASOLINA COURO DFV 444 CURTO<br/>400262</p> | <p><b>T-4263</b></p>  <p>PISTÃO INJETOR GASOLINA TEFLON DFV 444 LONGO<br/>401262</p> | <p><b>T-4275</b></p>  <p>PISTÃO INJETOR GASOLINA COURO DFV 444 LONGO<br/>400275</p> | <p><b>T-4360</b></p>  <p>PISTÃO INJETOR GASOLINA COURO GM 228<br/>400.360.02</p>  |
| <p><b>T-4381</b></p>  <p>PISTÃO INJETOR GASOLINA COURO<br/>400.381.02</p>          | <p><b>T-4393</b></p>  <p>PISTÃO INJETOR GASOLINA COURO<br/>400.393.02</p>           | <p><b>T-4409</b></p>  <p>PISTÃO INJETOR ÁLCOOL TEFLON FORD DFV<br/>401.409.02</p>  | <p><b>T-4470</b></p>  <p>PISTÃO INJETOR GASOLINA COURO GM 6CC<br/>400.470.02</p> |
| <p><b>T-4546</b></p>  <p>PISTÃO INJETOR ÁLCOOL TEFLON GM 446<br/>401.546.02</p>    | <p><b>T-4767</b></p>  <p>PISTÃO INJETOR GASOLINA COURO<br/>401.767.02</p>           | <p><b>T-4770</b></p>  <p>PISTÃO INJETOR GASOLINA COURO GM 4CC<br/>400.770.02</p>   | <p><b>T-4802</b></p>  <p>PISTÃO INJETOR GASOLINA COURO GM DFV<br/>400.802.02</p> |
| <p><b>T-4854</b></p>  <p>PISTÃO INJETOR GASOLINA COURO GM 446<br/>400.854.02</p>   | <p><b>T-4887</b></p>  <p>PISTÃO INJETOR GASOLINA COURO FORD 228<br/>400.887.02</p>  |  |   |

**160 INJETORES E GICLEURS**

**160 INJETORES E GICLEURS**

|   |   |  |  |
|---|---|--|--|
| <p><b>T-2101/40</b></p>  <p>INJETOR FUSCA - SEDAN 1300 - 30-PIC</p> <p>112.197/40</p>                        | <p><b>T-2101/45</b></p>  <p>INJETOR FUSCA - SEDAN 1300 - 30-PIC-2</p> <p>112.235/45</p>  | <p><b>T-2101/50</b></p>  <p>INJETOR FUSCA - KOMBI/K. GUIA 1200 - 30-PICS</p> <p>112.207/50</p>                     | <p><b>T-2101/55</b></p>  <p>INJETOR FUSCA - KOMBI/BRASILIA - 30-PIC</p> <p>112.207/55</p>   |
| <p><b>T-2101/60</b></p>  <p>INJETOR FUSCA - FUSCÃO 1500 - 30-PICT</p> <p>112.219/60</p>                      | <p><b>T-2101/70</b></p>  <p>INJETOR FUSCA - KOMBI/FUSCÃO/K. GUIA - 30-PIC</p> <p>112.207/70</p>                                | <p><b>T-2101/75</b></p>  <p>INJETOR FUSCA</p> <p>112.207/75</p>  | <p><b>T-2102/40</b></p>  <p>INJETOR BRASÍLIA - VARIANT/BRASILIA/KOMBI 1600 - 32-PDSI 2/3</p> <p>114.332/40</p>                      |
| <p><b>T-2102/45</b></p>  <p>INJETOR BRASÍLIA - GOL 1600 - PDSIT 2/3</p> <p>114.235/45</p>                   | <p><b>T-2102/50</b></p>  <p>INJETOR BRASÍLIA - VARIANT TC, TL 1600 - 32-PDSIT 2/3</p> <p>114.232/50</p>                       | <p><b>T-2102/55</b></p>  <p>INJETOR BRASÍLIA - GOL 1600 - 32-PDSIT 2/3</p> <p>114.235/55</p>                      | <p><b>T-2102/60</b></p>  <p>INJETOR BRASÍLIA - BRASILIA/GOL 1300 - 32-PDSIT 2/3</p> <p>119.153/60</p>                              |
| <p><b>T-2102/70</b></p>  <p>INJETOR BRASÍLIA - KOMBI/SEDAN 1600 - 32-PDSIT 2/3</p> <p>119.236/70</p>       | <p><b>T-2103/100</b></p>  <p>INJETOR PASSAT/CHEVETTE - CHEVETTE/HATCH/MARAJÓ/CHEVY 500 1600 - 35-PDSI</p> <p>040.254/100</p> | <p><b>T-2103/120</b></p>  <p>INJETOR PASSAT/CHEVETTE - 35-PDSIT</p> <p>040.252/120</p>                           | <p><b>T-2103/50</b></p>  <p>INJETOR PASSAT/CHEVETTE - PASSAT/VOYAGE 1500 - 35-PDSIT</p> <p>040.251/50</p>                         |
| <p><b>T-2103/60</b></p>  <p>INJETOR PASSAT/CHEVETTE - PASSAT/VOYAGE 1500 - 35-PDSIT</p> <p>040.252/60</p>  | <p><b>T-2103/80</b></p>  <p>INJETOR PASSAT/CHEVETTE - CHEVETTE/HATCH/MARAJÓ 1.4 - 35-PDSIT</p> <p>040.253/80</p>             | <p><b>T-2103/85</b></p>  <p>INJETOR PASSAT/CHEVETTE - CHEVETTE/HATCH/MARAJÓ 1.4 - 35-PDSIT</p> <p>040.254/85</p> | <p><b>T-2104/40</b></p>  <p>INJETOR KOMBI/CORCEL - KOMBI 1.6 - 32-PDSIT</p> <p>114.236/40</p>                                     |
| <p><b>T-2104/50</b></p>  <p>INJETOR KOMBI/CORCEL - CORCEL/BELINA 1400 - 32-PDSIT 2/3</p> <p>113.165/50</p> | <p><b>T-2104/60</b></p>  <p>INJETOR KOMBI/CORCEL - CORCEL/BELINA 1400 - 34-PDSI</p> <p>113.165/60</p>                        | <p><b>T-2104/70</b></p>  <p>INJETOR KOMBI/CORCEL - KOMBI 1.6 - 32-PDSIT 2/3</p> <p>114.236/70</p>                | <p><b>T-2105/100</b></p>  <p>INJETOR MONZA/ESCORT/CORCEL/GOL BLFA - ESCORT/CORCEL/BELINA/PAMPA -30/34-BLFA</p> <p>160.252/100</p> |



**160 INJETORES E GICLEURS**

|   |   |  |  |
|---|---|--|--|
| <p><b>T-2105/50</b></p>  <p>INJETOR MONZA/ESCORT/CORCEL/GOL BLFA - GOL/VOYAGE/PARATI/SAV 1.6 - 30/34-BLFA<br/>130.025/50</p> | <p><b>T-2105/80</b></p>  <p>INJETOR MONZA/ESCORT/CORCEL/GOL BLFA - ESCORT/CORCEL/BELINA/PAMPA -30/34-BLFA<br/>160.251/80</p> | <p><b>T-2106/100</b></p>  <p>INJETOR MONZA/FIAT ALFA - FIAT 147 1.3 TODOS - 35-ALFA-1<br/>160.025/100</p>          | <p><b>T-2106/50</b></p>  <p>INJETOR MONZA/FIAT ALFA - MONZA 1.6 - 35-ALFA-1<br/>160.025/50</p>                        |
| <p><b>T-2106/80</b></p>  <p>INJETOR MONZA/FIAT ALFA - MONZA 1.8 - 35-ALFA-1<br/>160.025/80</p>                               | <p><b>T-2107/50</b></p>  <p>INJETOR FIAT - FIAT 147 TODOS 1050/1300 - 32-DIS-1/3<br/>070.021/50</p>                          | <p><b>T-2107/65</b></p>  <p>INJETOR FIAT - FIAT 147 TODOS 1300 - 32-DIS-2<br/>070.021/65</p>                       | <p><b>T-2107/70</b></p>  <p>INJETOR FIAT - FIAT 147 TODOS 1300 - 32-DIS-2<br/>070.021/70</p>                          |
| <p><b>T-2108/35</b></p>  <p>INJETOR 2E - MONZA/KADETT/SANTANA/GOL/PASSAT/VOYAGE/QUANTUM - 2 E 7<br/>175.251/35</p>          | <p><b>T-2108/40</b></p>  <p>INJETOR 2E<br/>176.251/40</p>   | <p><b>T-2108/45</b></p>  <p>INJETOR 2E - PAMPA 1.8 - 2 E CE<br/>175.257/45</p>                                    | <p><b>T-2108/50</b></p>  <p>INJETOR 2E - 2 E 7<br/>175.257/50</p>  |
| <p><b>T-2108/55</b></p>  <p>INJETOR 2E - KADETT/MONZA 2.0 - 2 E 7<br/>175.025/55</p>                                       | <p><b>T-2108/60</b></p>  <p>INJETOR 2E - MONZA/KADETT/OPALA 4 E 6 CIL/SANTANA/ESCORT/VERONA - 2 E 7<br/>174.025/60</p>     | <p><b>T-2108/70</b></p>  <p>INJETOR 2E - SANTANA/GOL GT/PASSAT/VOYAGE 1.8/QUANTUM 2.0 - 2 E 7<br/>175.252/70</p> | <p><b>T-2108/80</b></p>  <p>INJETOR 2E - OPALA 6 CIL - 2 E 7<br/>175.253/80</p>                                     |
| <p><b>T-2109/35</b></p>  <p>INJETOR 3E - SANTANA/QUANTUM 2.0 - 2 E 7<br/>176.252/35</p>                                    | <p><b>T-2109/60</b></p>  <p>INJETOR 3E - SANTANA/QUANTUM 2.0 - 3E<br/>176.253/60</p>                                       | <p><b>T-2109/70</b></p>  <p>INJETOR 3E - SANTANA/QUANTUM - 3E<br/>176.252/70</p>                                 | <p><b>T-2109/80</b></p>  <p>INJETOR 3E - SANTANA/QUANTUM/PASSAT/GOL/VOYAGE/PARATI 1.8 E 2.0 - 3E<br/>176.252/80</p> |
| <p><b>T-2115/40</b></p>  <p>INJETOR BLFA 1FURO - GOL/VOYAGE/PARATI/SAVEIRO - 1.630/34-BLFA<br/>130.251/40</p>              | <p><b>T-2115/50</b></p>  <p>INJETOR BLFA 1FURO - GOL/VOYAGE/PARATI/SAVEIRO - 1.630/34-BLFA<br/>130.251/50</p>              | <p><b>T-2115/70</b></p>  <p>INJETOR BLFA 1FURO - GOL/VOYAGE/PARATI/SAVEIRO - 1.630/34-BLFA<br/>130.251/70</p>    | <p><b>T-2115/80</b></p>  <p>INJETOR BLFA 1FURO - ESCORT/CORCEL/BELINA/DEL REY 1.6 - 30/34-BLFA<br/>130.251/80</p>   |

**160 INJETORES E GICLEURS**

|   |   |  |  |
|---|---|--|--|
| <p><b>T-2116/80</b></p>  <p>INJETOR BLFA 2FUROS - MONZA 1.6/1.8 - 30/34-BLFA<br/>130.025/80</p>                        | <p><b>T-2150/35-7</b></p>  <p>INJETOR CHT - GOL LINHA 1000 - 460<br/>484.803/52</p>                        | <p><b>T-2150/40-2</b></p>  <p>INJETOR CHT - FIAT 1.5/FIAT 147/UNO 1.3/ UNO S/CS 1.3/UNO MILLE - 190<br/>463.604/02</p> | <p><b>T-2150/40-7</b></p>  <p>INJETOR CHT - GOL/PARATI/VOYAGE/SAVEIRO 1.6 - 460<br/>467.804/02</p>                |
| <p><b>T-2150/45-2</b></p>  <p>INJETOR CHT - FIAT 147/FIORINO/SPAZIO 1050 - 190<br/>463.604/02</p>                      | <p><b>T-2150/45-7</b></p>  <p>INJETOR CHT - FIAT 1.5 UNO/UTILITÁRIOS - 190<br/>467.804/52</p>              | <p><b>T-2150/50-7</b></p>  <p>INJETOR CHT<br/>467.805/02</p>   | <p><b>T-2151/35-7</b></p>  <p>INJETOR CHT - GOL LINHA 1000 - 460<br/>484.803/52</p>                               |
| <p><b>T-2151/40-2</b></p>  <p>INJETOR CHT - FIAT 1.3/FIORINO/PANORAMA/PICK-UP/UNO/PRÊMIO 1.3 - 190<br/>464.704/02</p> | <p><b>T-2151/40-7</b></p>  <p>INJETOR CHT - VOYAGE/PARATI/GOL 1.6/SAVEIRO AE 1.6 - 460<br/>467.004/02</p> | <p><b>T-2151/45-2</b></p>  <p>INJETOR CHT - FIAT 147/FIORINO/SPAZIO 1050 - 190<br/>463.604/02</p>                     | <p><b>T-2151/45-7</b></p>  <p>INJETOR CHT - FIAT 1.5 UNO/UTILITÁRIOS - 190<br/>467.804/52</p>                    |
| <p><b>T-2151/50-7</b></p>  <p>INJETOR CHT - UNO 1.5R/PRÊMIO/ELBA 1.5 - 460 E 190<br/>467.005/02</p>                  | <p><b>T-2151/55-9</b></p>  <p>INJETOR CHT - MONZA 1.6 - 190<br/>465.905/52</p>                           | <p><b>T-2151/60-7</b></p>  <p>INJETOR CHT - CHEVETTE 1.6-S - 460<br/>467.006/02</p>                                  | <p><b>T-2151/70-7</b></p>  <p>INJETOR CHT - UNO SX 1.300<br/>467.007/02</p>                                     |
| <p><b>T-2152/35</b></p>  <p>INJETOR TLDF - TODA LINHA FIAT 1.5 E 1.6 - 495-TLDF<br/>486.803/52</p>                   | <p><b>T-2152/42</b></p>  <p>INJETOR TLDF - FIAT-994CC/UNO MILLE C/ INJ. - 495-TLDF<br/>486.804/22</p>    | <p><b>T-2152/45</b></p>  <p>INJETOR TLDF - ELBA/UNO/PRÊMIO 1.6 - 495-TLDF<br/>486.804/52</p>                         | <p><b>T-2153/35</b></p>  <p>INJETOR TLDF - TODA LINHA FIAT 1.5 E 1.6 - 495-TLDF<br/>486.803/52</p>              |
| <p><b>T-2153/42</b></p>  <p>INJETOR TLDF - FIAT-994CC/UNO MILLE C/ INJ. - 495-TLDF<br/>486.804/22</p>                | <p><b>T-2153/45</b></p>  <p>INJETOR TLDF - ELBA/UNO/PRÊMIO 1.6 - 495-TLDF<br/>486.704/52</p>             | <p><b>T-2153/62</b></p>  <p>INJETOR TLDF - TODA LINHA FIAT 1.5 E 1.6 - 495-TLDF<br/>486.806/22</p>                   | <p><b>T-2154/35</b></p>  <p>INJETOR TLDZ - VOYAGE/PARATI/GOL/SAVEIRO 1.8 - 495-TLDE/495-TLDZ<br/>486.403/52</p> |

**160 INJETORES E GICLEURS**

|  |   |   |   |
|--|---|---|---|
| <p><b>T-2154/40</b></p>  <p>INJETOR TLDZ - VOYAGE/PARATI/GOL/SAVEIRO 1.8 - 495-TLDZ<br/>486.404/02</p>                      | <p><b>T-2154/42</b></p>  <p>INJETOR TLDZ - UNO C/ INJEÇÃO MAPEADA - 495-TLDZ<br/>471.504/22</p>                        | <p><b>T-2154/45</b></p>  <p>INJETOR TLDZ - TODA LINHA VW 1.8 - 495-TLDZ<br/>486.404/52</p>                                  | <p><b>T-2154/50</b></p>  <p>INJETOR TLDZ - ESCORT 1.8 - 495-TLDZ<br/>486.405/02</p>  |
| <p><b>T-2154/55</b></p>  <p>INJETOR TLDZ - SANTANA/QUANTUM/PARATI/GOL/SAVEIRO 1.8 - 495-TLDZ<br/>486.305/52</p>             | <p><b>T-2154/60</b></p>  <p>INJETOR TLDZ - GOL/SAVEIRO/PARATI/VOYAGE 1.6 - 495-TLDZ<br/>486.306/02</p>                 | <p><b>T-2154/70</b></p>  <p>INJETOR TLDZ<br/>486.306/70</p>   | <p><b>T-2155/40</b></p>  <p>INJETOR MINI PROGRESSIVO - TODA LINHA VW 1.6 - 450-MINI<br/>464.204/02</p>                         |
| <p><b>T-2155/45</b></p>  <p>INJETOR MINI PROGRESSIVO - PASSAT/GOL/VOYAGE/PARATI 1.6 - 450.103 MINI<br/>464.204/52</p>      | <p><b>T-2155/50</b></p>  <p>INJETOR MINI PROGRESSIVO - PASSAT/VOYAGE/PARATI/GOL 1.6 - 450.400 MINI<br/>464.205/02</p> | <p><b>T-2155/52</b></p>  <p>INJETOR MINI PROGRESSIVO - CORCEL II/BELINA II/DEL REY 1.6 - 450-MINI<br/>464.205/22</p>       | <p><b>T-2155/55</b></p>  <p>INJETOR MINI PROGRESSIVO - TODA LINHA VW 1.6 - 450-MINI<br/>464.205/52</p>                        |
| <p><b>T-2155/60</b></p>  <p>INJETOR MINI PROGRESSIVO - TODA LINHA VW 1.6 - 450-MINI<br/>467.706/02</p>                    | <p><b>T-2155/65</b></p>  <p>INJETOR MINI PROGRESSIVO - PASSAT/VOYAGE/PARATI/GOL 1.6 - 450-MINI<br/>467.706/52</p>    | <p><b>T-2155/70</b></p>  <p>INJETOR MINI PROGRESSIVO - PASSAT/VOYAGE 1.6 - 450.302-MINI/450.310 MINI<br/>482.007/02</p>   | <p><b>T-2155/85</b></p>  <p>INJETOR MINI PROGRESSIVO - CHEVETTE 1.4 - 450-MINI<br/>464.408/52</p>                            |
| <p><b>T-2201/40</b></p>  <p>GICLEUR DE MARCHA LENTA SOLEX<br/>11.069/40</p>   | <p><b>T-2201/42,5</b></p>  <p>GICLEUR DE MARCHA LENTA SOLEX<br/>11.069/42,5</p>                                      | <p><b>T-2201/45</b></p>  <p>GICLEUR DE MARCHA LENTA SOLEX<br/>11.069/45</p>   | <p><b>T-2201/47,5</b></p>  <p>GICLEUR DE MARCHA LENTA SOLEX<br/>11.069/47,5</p>  |
| <p><b>T-2201/50</b></p>  <p>GICLEUR MARCHA LENTA - ALFA ROMEO/PICK-UP/CHEVETTE - 34-SEIE/40-EIS/34-SEIE<br/>11.069/50</p> | <p><b>T-2201/52,5</b></p>  <p>GICLEUR DE MARCHA LENTA SOLEX<br/>11.069/52,5</p>                                      | <p><b>T-2201/55</b></p>  <p>GICLEUR MARCHA LENTA - CORCEL II/BELINA II/OPALA/CHEVETTE - 34-SEIE/34-PDSI<br/>11.069/55</p> | <p><b>T-2201/57,5</b></p>  <p>GICLEUR DE MARCHA LENTA SOLEX - MAVERICK 4CIL/PICK-UP F1000 4CIL - 34-SEIE<br/>11.069/57,5</p> |



**160 INJETORES E GICLEURS**

|  |  |   |  |
|--|--|---|--|
| <p><b>T-2201/60</b></p> <p>GICLEUR DE MARCHA LENTA SOLEX</p> <p>11.069/60</p>  | <p><b>T-2201/62,5</b></p> <p>GICLEUR MARCHA LENTA - ALFA ROMEO 2300/CHEVETTE/MARAJÓ 1.4 - 34-SEIE/35-PDSI</p> <p>11.069/62,5</p> | <p><b>T-2201/65</b></p> <p>GICLEUR MARCHA LENTA - JEEP/PICK-UP/RURAL 4CC/CORCEL II/OPALA - 40-DEIS/34-SEIE</p> <p>11.069/65</p> | <p><b>T-2201/67,5</b></p> <p>GICLEUR DE MARCHA LENTA SOLEX - OPALA/CARAVAN/PICK-UP 2.5 4 CIL - 34-SEIE</p> <p>11.069/67,5</p>  |
| <p><b>T-2201/70</b></p> <p>GICLEUR MARCHA LENTA - FIAT 147/UNO/CHEVETTE/OPALA - 35-ALFA 1/34-SEIE/40-DEIS</p> <p>11.069/70</p> | <p><b>T-2201/72,5</b></p> <p>GICLEUR MARCHA LENTA - UNO/PRÊMIO/OPALA/CARAVAN/ 35-ALFA 1/34-SEIE/40-DEIS</p> <p>11.069/72,5</p>   | <p><b>T-2201/75</b></p> <p>GICLEUR DE M.LENTA SOLEX - MONZA 1.6/PICK-UP/VERANEIO 6CIL - 35-ALFA 1/34-SEIE</p> <p>11.069/75</p>  | <p><b>T-2201/77,5</b></p> <p>GICLEUR MARCHA LENTA- OPALA/PICK-UP 2.5 4CIL/MONZA 1.8 - 34-SEIE/35-ALFA 1</p> <p>11.069/77,5</p> |
| <p><b>T-2201/80</b></p> <p>GICLEUR MARCHA LENTA - MAVERICK 4CIL/CHEVETTE/MARAJÓ 1.4/OPALA - 34-SEIE</p> <p>11.069/80</p>       | <p><b>T-2201/85</b></p> <p>GICLEUR DE MARCHA LENTA SOLEX</p> <p>11.069/85</p>  | <p><b>T-2201/90</b></p> <p>GICLEUR DE MARCHA LENTA SOLEX</p> <p>11.069/90</p>   | <p><b>T-2201/95</b></p> <p>GICLEUR MARCHA LENTA - /CHEVETTE/MARAJÓ/OPALA/VERANEIO 6CIL - 40-DEIS/34-SEIE</p> <p>11.069/95</p>  |
| <p><b>T-2501</b></p> <p>AGULHA DO ECONOSTAT (FOGUETINHO) - PASSAT/VOYAGE 1.500 - 35-PDSIT/35-PDSI</p> <p>40003</p>             |  |   |  |

**165 PARAFUSO MARCHA L.**

|   |  |   |   |
|---|--|---|---|
| <p><b>M-11.026</b></p> <p>PARF. M.L. - FUSCA - 30 PIC</p> <p>00026</p>                                    | <p><b>M-130.346</b></p> <p>PARF. M.L. - BLFA - SOLEX</p> <p>10346 - 175346 - 130345 - 130343</p> | <p><b>M-170.231</b></p> <p>PARF. M.L. - 2E - SOLEX</p> <p>30231</p>   | <p><b>M-175.481</b></p> <p>PARF. M.L. - 2E - CURTA - SOLEX</p> <p>32481 - 175348</p>      |
| <p><b>M-175.492</b></p> <p>PARF. M.L. - 2E/3E - LONGA - SOLEX</p> <p>32492 - 175491 - 175492 - 130491</p> | <p><b>M-3.238</b></p> <p>PARF. M.L. - BRASILIA - 32 PDSIT</p> <p>1238</p>                        | <p><b>M-3.482</b></p> <p>PARF. M.L. - OPALA - 34 SEIE</p> <p>1482</p> | <p><b>M-32.178</b></p> <p>PARF. M.L. - FIAT 147 - 32 DIS - SOLEX</p> <p>11178 - 32108</p> |

**165 PARAFUSO MARCHA L.**

|  |  |   |   |
|--|--|---|---|
| <p><b>M-32.180</b></p> <p>PARF. M.L. - KOMBI MODERNA - 32 PDSI - SOLEX</p> <p>11180 - 34115A</p>     | <p><b>M-32.181</b></p> <p>PARF. M.L.</p> <p>11181 - 401251 - 402251</p>                                  | <p><b>M-34.115</b></p> <p>PARF. M.L. - CORCEL/MAVERICK - 34 SEIE - LONGA</p> <p>12115</p>       | <p><b>M-40.235</b></p> <p>PARF. M.L. - ALFA 1 - FIAT SOLEX</p> <p>20235 - 40271</p>     |
| <p><b>M-40.238</b></p> <p>PARF. M.L. - ALFA 1</p> <p>20238 - 40234</p>                               | <p><b>M-401.054</b></p> <p>PARF. M.L. - 446 - WEBER</p> <p>200054</p>                                    | <p><b>M-401.057</b></p> <p>PARF. M.L. - DFV - OPALA</p> <p>200057</p>                           | <p><b>M-401.483</b></p> <p>PARF. M.L. - TLDF 190/495 - WEBER</p> <p>200483 - 401883</p> |
| <p><b>M-401.653</b></p> <p>PARF. M.L. - MINI PROGRESSIVO 450 - WEBER</p> <p>200653</p>               | <p><b>M-402.113</b></p> <p>PARF. M.L. - MINI PROGRESSIVO 450 - WEBER</p> <p>201113 - 402212 - 401212</p> | <p><b>M-402.251</b></p> <p>PARF. M.L. - FORD ALCOOL - WEBER</p> <p>201251 - 401251 - 401056</p> | <p><b>M-402.373</b></p> <p>PARF. M.L. - 190 - WEBER</p> <p>201373</p>                   |
| <p><b>M-402.511</b></p> <p>PARF. M.L. - CHT 460 - WEBER</p> <p>201511 - 401837 - 402837 - 402852</p> | <p><b>M-402.989</b></p> <p>PARF. M.L. - TLDZ 495 - WEBER</p> <p>201989</p>                               | <p><b>M-403.632</b></p> <p>PARF. M.L. - TLDF 460/495 - WEBER</p> <p>201632 - 403.497</p>        |   |

**170 VÁLV.BÓIA SOLEX**

|  |   |  |  |
|--|---|--|--|
| <p><b>M-3012</b></p> <p>VÁLV.BÓIA MONZA/GOL - 35-ALFA1 / 32-PDSI - V.151</p> <p>112122 - 001122 - 112100 - 114101 - 160126</p> | <p><b>M-3030</b></p> <p>VÁLV.BÓIA ESCORT - 30/34 BLFA C.DUPL0 - V.176</p> <p>130111 - 010111 - 130112</p> | <p><b>M-3033</b></p> <p>VÁLV.BÓIA MONZA 1.8 - 30/34 BLFA C.DUPL0 - V.221</p> <p>130113 - 010113</p>                      | <p><b>M-3034</b></p> <p>VÁLV.BÓIA CHEVETTE ÁLCOOL - 35-PDSI - V.176</p> <p>40104 - 20104 - 55103 - 40462 - 40460 - 55100</p> |
| <p><b>M-3054</b></p> <p>VÁLV.BÓIA PASSAT ÁLCOOL - 35-PDSI - V.176</p> <p>40444</p>   | <p><b>M-3055</b></p> <p>VÁLV.BÓIA OPALA/JEEP/FUSCA - 40-EIS/30-PIC - V.151</p> <p>40443 - 20443</p>       | <p><b>M-3056</b></p> <p>VÁLV.BÓIA BRASILIA - 32 - PDS IT2/3 C.DUPL0 - V.121</p> <p>114123 - 002123 - 114156 - 114100</p> | <p><b>M-3057</b></p> <p>VÁLV.BÓIA CORCEL/OPALA/CHEVETTE - 34-SEIE - V.151</p> <p>54120 - 22120</p>                           |

**170 VÁLV.BÓIA SOLEX**

|  |   |  |  |
|--|---|--|--|
| <p><b>M-3058</b></p>  <p>VÁLV.BÓIA OPALA 4CC/6CC ÁLCOOL - 34-SEIE - V.222</p> <p>54109 - 22109</p>                    | <p><b>M-3059</b></p>  <p>VÁLV.BÓIA FIAT 147-32-DIS2/40-DEIS/34-DEIS - V.200</p> <p>70121 - 30121 - 70446</p> | <p><b>M-3060</b></p>  <p>VÁLV.BÓIA MONZA 1.6/1.8 - ÁLCOOL - 35-ALFA-1 - V.176</p> <p>160108 - 30108</p>              | <p><b>M-3061</b></p>  <p>VÁLV.BÓIA FUSCA - 30-PIC / 40-EIS - V.151</p> <p>11118 - 00118 - 70445 - 54101 - 70443 - 50156 - 18116</p> |
| <p><b>M-3062</b></p>  <p>VÁLV.BÓIA FUSCA/BRASILIA - 30-PIC - V.150</p> <p>11230 - 00230</p>                           | <p><b>M-3063</b></p>  <p>VÁLV.BÓIA PASSAT - 35-PDSIT/31-PICT/32-DIS - V.151</p> <p>40119</p>                 | <p><b>M-3065</b></p>  <p>VÁLV.BÓIA SANT/GOL/MONZA - (POCINHO) 2E7 - V.2.5</p> <p>175102 - 32102 - 20118 - 175100</p> | <p><b>M-3066</b></p>  <p>VÁLV.BÓIA SANT/GOL 1.8 - CHUVEIRINHO - 2E/3E - V.2.5</p> <p>175125 - 32125</p>                             |
| <p><b>M-3068</b></p>  <p>VÁLV.BÓIA KOMBI 1.6 - CARB. 114570/571 - V.151</p> <p>114122 - 002122 - 114570 - 114571</p> | <p><b>M-3086</b></p>  <p>VÁLV.BÓIA</p> <p>174128 - 32128 - 15250</p>  | <p><b>M-3087</b></p>  <p>VÁLV.BÓIA</p> <p>54100 - 22100 - 185105 - 50104</p>  |  |

**175 VÁLV.BÓIA WEBER**

|  |   |  |   |
|--|---|--|---|
| <p><b>M-3017</b></p>  <p>VÁLV.BÓIA GOL 1.6/ESCORT 1.6 - 460 - V.175 - CHT</p> <p>488317 - 244317 - 467917</p> | <p><b>M-3018</b></p>  <p>VÁLV.BÓIA FIAT 147/UNO/PREMIO 1.3 - 190 - V.175</p> <p>488517 - 244517 - 485415</p>             | <p><b>M-3019</b></p>  <p>VÁLV.BÓIA UNO 1.5 - 495 - V.225</p> <p>488522 - 244522</p>                                  | <p><b>M-3025</b></p>  <p>VÁLV.BÓIA UNO 1.6/PREMIO/ELBA - 495 - V.250 - CHT</p> <p>488325 - 244325</p>              |
| <p><b>M-3042</b></p>  <p>VÁLV.BÓIA CORCEL/OPALA 4/6 CC - 228 - V.200 - BAIXA</p> <p>463020 - 231020</p>       | <p><b>M-3045</b></p>  <p>VÁLV.BÓIA GOL/PASSAT 1.6/CHEVETTE - 450 - V.220 - MINI</p> <p>465022 - 232022 - 472222</p>      | <p><b>M-3046</b></p>  <p>VÁLV.BÓIA GOL/PASSAT 1.6/CHEVETTE - 450 - V.200 - MINI</p> <p>465020 - 232020 - 472220</p>  | <p><b>M-3049</b></p>  <p>VÁLV.BÓIA CORCEL LL/BELINA/DEL REY 1.6 - 228 - V.200</p> <p>449220 - 224220</p>           |
| <p><b>M-3050</b></p>  <p>VÁLV.BÓIA CORCEL/CHEVETTE 1.4/1.6 - 228 - V.200 - ALTA</p> <p>463120 - 231120</p>    | <p><b>M-3051</b></p>  <p>VÁLV.BÓIA GOL/UNO/ESCORT - 460 / 495 - V.225 - CHT</p> <p>488322 - 244322 - 467922 - 482222</p> | <p><b>M-3052</b></p>  <p>VÁLV.BÓIA GOL/UNO/MONZA - 190 / 460 / 495 - V.200 - CHT</p> <p>488320 - 244320 - 488920</p> | <p><b>M-3053</b></p>  <p>VÁLV.BÓIA FIAT 147/UNO/PREMIO 1.3 - 190 - V.150 - CHT</p> <p>488315 - 244315 - 467915</p> |

**175 VÁLV.BÓIA WEBER**

|   |  |  |  |
|---|--|--|--|
| <p><b>M-3067</b></p>  <p>VÁLV.BÓIA OPALA/CARAVAN 4/6 CC - 446 - V.250</p> <p>461625 - 230625</p> | <p><b>M-3085</b></p>  <p>VÁLV.BÓIA</p> <p>488520 - 244520</p> | <p><b>M-3088</b></p>  <p>VÁLV.BÓIA</p> <p>462320 -231320</p> |  |
|---|--|--|--|

**180 TUBO, GICLEUR ML, RESPIRO E PORTA GICLEUR**

|   |  |   |  |
|---|--|---|--|
| <p><b>M-5083</b></p>  <p>TUBO MISTURADOR WEBER 446 - 70 - ÁLCOOL</p> <p>316.200.02</p>               | <p><b>M-5084</b></p>  <p>TUBO MISTURADOR WEBER 446 - 52 - GASOLINA</p> <p>312.900.02</p>          | <p><b>M-5085</b></p>  <p>TUBO MISTURADOR WEBER 446 - A-7 - GASOLINA</p> <p>327.300.02</p>         | <p><b>M-5086</b></p>  <p>TUBO MISTURADOR WEBER 446 - A-9 - ÁLCOOL</p> <p>331.600.02</p>           |
| <p><b>M-5087</b></p>  <p>TUBO MISTURADOR WEBER 446 - DODGE V8 - GASOLINA</p> <p>309.500.02</p>       | <p><b>M-5313/13</b></p>  <p>GLICEUR DE MARCHA LENTA WEBER 446 DFV -</p> <p>445.013.12</p>        | <p><b>M-5313/47</b></p>  <p>GLICEUR DE MARCHA LENTA WEBER 446 DFV</p> <p>445.047.12</p>          | <p><b>M-5313/55</b></p>  <p>GLICEUR DE MARCHA LENTA WEBER 446 DFV</p> <p>445.055.12</p>          |
| <p><b>M-5313/65</b></p>  <p>GLICEUR DE MARCHA LENTA WEBER 446 DFV</p> <p>445.065.12</p>            | <p><b>M-5313/80</b></p>  <p>GLICEUR DE MARCHA LENTA WEBER 446 DFV</p> <p>445.080.12</p>         | <p><b>M-5356/125</b></p>  <p>GICLEUR PRINCIPAL COMBUSTIVEL 446-DFV - V.25</p> <p>309.125/32</p> | <p><b>M-5356/130</b></p>  <p>GICLEUR PRINCIPAL COMBUSTIVEL 446-DFV - V.26</p> <p>309.130/32</p> |
| <p><b>M-5356/135</b></p>  <p>GICLEUR PRINCIPAL COMBUSTIVEL 446-DFV - V.27</p> <p>309.135/32</p>    | <p><b>M-5356/165</b></p>  <p>GICLEUR PRINCIPAL COMBUSTIVEL 446-DFV - V.33</p> <p>309.165/32</p> | <p><b>M-5380</b></p>  <p>RESPIRO DE AR WEBER 228/446 DFV - VAZÃO 100</p>                        | <p><b>M-5381</b></p>  <p>PORTA GICLEUR PRINCIPAL - SOLEX FUSCA</p> <p>2814</p>                  |
| <p><b>M-5382</b></p>  <p>PORTA GICLEUR PRINCIPAL - SOLEX FUSCA - MAJORADO</p> <p>2814 MAJORADO</p> |  |   |  |

**185 CONEXÃO E TUBO**



**185 CONEXÃO E TUBO**

|   |   |  |   |
|---|---|--|---|
| <p><b>T-5353</b></p>  <p>"T" 3/16 PARTIDA À FRIO/AVANÇO MANGUEIRA 3,5MM EM LATÃO</p> | <p><b>T-5354</b></p>  <p>"T" ¼ PARA COMBUSTÍVEL MANGUEIRA 5MM EM LATÃO</p> | <p><b>T-5355</b></p>  <p>CONEXÃO RETA PARA INJEÇ.ELETR.MANGUEIRA 7 MM EM LATÃO</p> | <p><b>T-5418</b></p>  <p>BUCHA CABO ACELERADOR BRASILIA - QUEBRA GALHO</p> |
| <p><b>T-5419</b></p>  <p>BUCHA CABO ACELERADOR DO FUSCA - QUEBRA GALHO</p>           | <p><b>T-5420</b></p>  <p>TUBO DE PARTIDA À FRIO</p>                        | <p><b>T-5421</b></p>  <p>TUBO ENTRADA COMB. MINI PROGRESSIVO WEBER 450</p>         | <p><b>T-5422</b></p>  <p>TUBO ENTRADA COMB. FUSCA</p>                      |

**190 PARAFUSO REGULADOR**

|   |  |  |   |
|---|--|--|---|
| <p><b>T-5401</b></p>  <p>PARAFUSO VW/FORD LE JETRÔNIC. BOSCH</p>                  | <p><b>T-5510</b></p>  <p>PARAFUSO TEMPRA 16V/SW/TIPO IAW-P8 MAGNETTI MARELLI</p> | <p><b>T-5592</b></p>  <p>PARAFUSO SANTANA/ESCORT - LE JETRÔNIC. BOSCH</p> | <p><b>T-5620</b></p>  <p>PARAFUSO UNOTURBO/1.6R - LE JETRÔNIC BOSCH</p> |
| <p><b>T-5625</b></p>  <p>PARAFUSO MONZA EF 500/CLASSIC91/KADETTE GSI - BOSCH</p> |  |  |   |



**195 BUCHA PARA EIXO**

|  |   |   |  |
|--|---|---|--|
| <p><b>T-1501</b></p>  <p>BUCHA DE APOIO DA BASE SOLEX<br/>2 X 10 X 8 MM</p> | <p><b>T-1502</b></p>  <p>BUCHA DA BASE<br/>13 X 10 X 8 MM</p>    | <p><b>T-1503</b></p>  <p>BUCHA DA BASE<br/>7 X 10 X 8 MM</p>                          | <p><b>T-1504</b></p>  <p>BUCHA DA BASE<br/>20 X 10 X 8 MM</p>                   |
| <p><b>T-1505</b></p>  <p>BUCHA DA BASE<br/>13 X 9 X 8 MM</p>                | <p><b>T-1506</b></p>  <p>BUCHA DA BASE<br/>20 X 11 X 7,95 MM</p> | <p><b>T-1507</b></p>  <p>BUCHA DA ALAV.DO BRAÇO ACEL.VOLKS<br/>2,8 X 10,93 X 8 MM</p> | <p><b>T-1508</b></p>  <p>BUCHA COM REBAIXO BASE SOLEX<br/>12 X 10 X 7,95 MM</p> |

**195 BUCHA PARA EIXO**

|  |  |  |  |
|--|--|--|--|
| <p><b>T-1509</b></p>  <p>BUCHA COM REBAIXO BASE CHT ½C</p> <p>16,5 X 11,5 X 8 MM</p>      | <p><b>T-1510</b></p>  <p>BUCHA COM REBAIXO BASE CHT 2C.</p> <p>18 X 10 X 8 MM</p> | <p><b>T-1511</b></p>  <p>BUCHA COM REBAIXO BASE TLDZ ½</p> <p>16,5 X 11,5 X 8 MM</p> | <p><b>T-1512</b></p>  <p>BUCHA COM REBAIXO BASE TLDZ 2C</p> <p>18,5 X 10 X 8 MM</p> |
| <p><b>T-1513</b></p>  <p>BUCHA DA BASE</p> <p>13 X 9,5 X 8 MM</p>                         | <p><b>T-1514</b></p>  <p>BUCHA DA BASE</p> <p>20 X 9,5 X 8 MM</p>                 | <p><b>T-1515</b></p>  <p>BUCHA DA BASE</p> <p>20 X 9 X 8 MM</p>                      | <p><b>T-1516</b></p>  <p>BUCHA DA HASTE DO PISTÃO INJ.DFV</p>                       |
| <p><b>T-1517</b></p>  <p>BUCHA DA BASE</p> <p>13 X 10 X 7,85 MM</p>                      | <p><b>T-1518</b></p>  <p>BUCHA DA BASE TLDE ½ CORPO</p> <p>16,5 X 12 X 8 MM</p>  | <p><b>T-1519</b></p>  <p>BUCHA DA BASE CHT ½ CORPO</p> <p>16,5 X 11,5 X 7,85MM</p>  | <p><b>T-1520</b></p>  <p>BUCHA DO 2º CORPO DO GOL 1000</p> <p>3 X 11,5 X 8 MM</p>  |
| <p><b>T-1521</b></p>  <p>BUCHA CORPO BORB.INJ.MONZA ROCH.</p> <p>14,5 X 13 X 9,5 MM</p> | <p><b>T-1553</b></p>  <p>BUCHA DA BASE</p> <p>7 X 10 X 7,85 MM</p>              | <p><b>T-1554</b></p>  <p>BUCHA DA BASE</p> <p>20 X 10 X 7,85 MM</p>                | <p><b>T-1555</b></p>  <p>BUCHA DA BASE</p> <p>13 X 9 X 7,85 MM</p>                |
| <p><b>T-1563</b></p>  <p>BUCHA DA BASE</p> <p>13 X 9,5 X 7,85 MM</p>                    | <p><b>T-1564</b></p>  <p>BUCHA DA BASE</p> <p>20 X 9,5 X 7,85 MM</p>            | <p><b>T-1565</b></p>  <p>BUCHA DA BASE</p> <p>20 X 9 X 7,85 MM</p>                 | <p><b>T-1566</b></p>  <p>BUCHA DA BASE</p> <p>10 X 9 X 8 MM</p>                   |
| <p><b>T-1567</b></p>  <p>BUCHA DA BASE</p> <p>10 X 9 X 7,85 MM</p>                      |  |  |  |

**200 PREPARAÇÃO - WEBER 40/44/45**

|  |  |   |   |
|--|--|---|---|
| <p><b>M-8001</b></p>  <p>CANETA WEBER 40 F-1</p>    | <p><b>M-8002</b></p>  <p>CANETA WEBER 40 F-2</p>    | <p><b>M-8003</b></p>  <p>CANETA WEBER 40 F-3</p>    | <p><b>M-8004</b></p>  <p>CANETA WEBER 40 F-4</p>               |
| <p><b>M-8005</b></p>  <p>CANETA WEBER 40 F-5</p>    | <p><b>M-8006</b></p>  <p>CANETA WEBER 40 F-6</p>    | <p><b>M-8007</b></p>  <p>CANETA WEBER 40 F-7</p>    | <p><b>M-8008</b></p>  <p>CANETA WEBER 40 F-8</p>               |
| <p><b>M-8009</b></p>  <p>CANETA WEBER 40 F-9</p>   | <p><b>M-8010</b></p>  <p>CANETA WEBER 40 F-10</p>  | <p><b>M-8011</b></p>  <p>CANETA WEBER 40 F-11</p>  | <p><b>M-8012</b></p>  <p>CANETA WEBER 40 F-12</p>             |
| <p><b>M-8014</b></p>  <p>CANETA WEBER 40 F-14</p> | <p><b>M-8015</b></p>  <p>CANETA WEBER 40 F-15</p> | <p><b>M-8016</b></p>  <p>CANETA WEBER 40 F-16</p> | <p><b>M-8017</b></p>  <p>CANETA WEBER 40 F-17</p>            |
| <p><b>M-8019</b></p>  <p>CANETA WEBER 40 F-19</p> | <p><b>M-8020</b></p>  <p>CANETA WEBER 40 F-20</p> | <p><b>M-8034</b></p>  <p>CANETA WEBER 40 F-34</p> | <p><b>M-8041</b></p>  <p>CANETA WEBER 40 F-41</p>            |
| <p><b>M-8047</b></p>  <p>CANETA WEBER 40 F-47</p> | <p><b>M-8049</b></p>  <p>CANETA WEBER 40 F-49</p> | <p><b>M-8050</b></p>  <p>CANETA WEBER 40 F-50</p> | <p><b>M-8101</b></p>  <p>GICLEUR MARCHA LENTA DCOE WEBER</p> |

**200 PREPARAÇÃO - WEBER 40/44/45**

|   |   |   |  |
|---|---|---|--|
| <p><b>M-8102</b></p>  <p>GICLEUR MARCHA LENTA IDF WEBER</p>                | <p><b>M-8103</b></p>  <p>GICLEUR AR DCOE/IDF WEBER</p>                         | <p><b>M-8104</b></p>  <p>GICLEUR COMBUSTÍVEL DCOE/IDF WEBER</p>                               | <p><b>M-8105</b></p>  <p>SUPORTE CANETA BAIXO</p>   |
| <p><b>M-8106</b></p>  <p>SUPORTE CANETA MÉDIO</p>                          | <p><b>M-8107</b></p>  <p>SUPORTE CANETA ALTO</p>                               | <p><b>M-8108</b></p>  <p>AGULHA DO BY PASS WEBER 40/44 IDF (C/ PORCA)</p>                     | <p><b>M-8109</b></p>  <p>AGULHA DE AR WEBER 40/44/48 IDF (C/ MOLA)</p>                        |
| <p><b>M-8110</b></p>  <p>SUPORTE MARCHA LENTA DCOE</p>                    | <p><b>M-8111</b></p>  <p>SUPORTE MARCHA LENTA IDF</p>                          | <p><b>M-8113</b></p>  <p>KIT CARB. WEBER 40/44 IDF ESPANHOLA (PINO C/MOLA) - (PINO ALTO)</p> | <p><b>M-8114</b></p>  <p>KIT CARB. WEBER 40/44 IDF ITALIANA (PINO S/MOLA) - (PINO BAIXO)</p> |
| <p><b>M-8115</b></p>  <p>KIT JUNTA SIMPLES WEBER 40/44 IDF (3 PEÇAS)</p> | <p><b>M-8116</b></p>  <p>KIT CARB. WEBER 40/45 DCOE</p>                      | <p><b>M-8117</b></p>  <p>KIT CARB. WEBER 46/48 IDA</p>                                      | <p><b>M-8118</b></p>  <p>KIT CARB. WEBER 48 IDF (PINO S/MOLA)</p>                           |
| <p><b>M-8119</b></p>  <p>VÁLVULA DE BÓIA IDA/48</p>                      | <p><b>M-8120</b></p>  <p>VÁLVULA DE BÓIA IDF/DCOE (TODAS VAZÕES)</p>         | <p><b>M-8121</b></p>  <p>VÁLVULA DE BÓIA 2E/3E (TODAS VAZÕES)</p>                           | <p><b>M-8122</b></p>  <p>INJETOR E PARAFUSO WEBER 40/44/48 IDF</p>                          |
| <p><b>M-8175/1</b></p>  <p>JOGO JUNTAS 2E - COM MANTA 0,8 DE ALGODÃO</p> | <p><b>M-8175/2</b></p>  <p>KIT CARB. SOLEX 2E - COM MANTA 0,8 DE ALGODÃO</p> | <p><b>M-8176/1</b></p>  <p>JOGO JUNTAS 3E - COM MANTA 0,8 DE ALGODÃO</p>                    | <p><b>M-8176/2</b></p>  <p>KIT CARB. SOLEX 3E - COM MANTA 0,8 DE ALGODÃO</p>                |

**205 TAMPA E CALÇO**



**205 TAMPA E CALÇO**

|   |  |   |  |
|---|--|---|--|
| <p><b>T-073</b></p> <p>JUNTA ESPASSADORA FIAT WEBER 190</p> <p>104487</p>           | <p><b>T-074</b></p> <p>JUNTA ESPASSADORA CHEVETTE</p> <p>105702</p>      | <p><b>T-075</b></p> <p>JUNTA ESPASSADORA FIAT SOLEX ALFA-1</p> <p>106701</p>    | <p><b>T-076</b></p> <p>JUNTA ESPASSADORA PASSAT</p> <p>107702</p>          |
| <p><b>T-077</b></p> <p>TAMPA DE NYLON VÁL. MAX. ALFA/BLFA/SOLEÇÃO</p> <p>204116</p> | <p><b>T-078</b></p> <p>JUNTA ESPASSADORA OPALA H40</p> <p>200.199.02</p> | <p><b>T-088</b></p> <p>VÁLVULA DA BOMBA DE ACELER. 2E UMBRELA</p> <p>175303</p> | <p><b>T-092</b></p> <p>BUCHA TRAVA P/ CARBURADORES WEBER LINHA 450/460</p> |
| <p><b>T-094</b></p> <p>TAMPA DE NYLON VÁL. MÁX. 2E</p> <p>204067</p>                |  |   |  |

**210 CALÇO, FLANGE E TERMINAL**

|   |  |   |   |
|---|--|---|---|
| <p><b>D-01</b></p> <p>BASE VW / BRASILIA / KOMBI</p> <p>341129795 - MATERIAL: BAQUELITE</p> | <p><b>D-02</b></p> <p>BASE FIAT 147</p> <p>94697856 - MATERIAL: BAQUELITE</p>              | <p><b>D-03</b></p> <p>BASE MINI PROGRESSIVO - 450</p> <p>ZBA129799 - MATERIAL: BAQUELITE</p>  | <p><b>D-04</b></p> <p>BASE MINI PROGRESSIVO - 450 COM CAVA</p> <p>ZBA129799 - MATERIAL: BAQUELITE</p> |
| <p><b>D-05</b></p> <p>BASE TLDZ</p> <p>1397993 - MATERIAL: BAQUELITE</p>                    | <p><b>D-06</b></p> <p>BASE 2E / 3E</p> <p>ZBA129799 - MATERIAL: BAQUELITE</p>              | <p><b>D-07</b></p> <p>FLANGE BOMBA COMBUSTÍVEL FIAT</p> <p>42504790 - MATERIAL: BAQUELITE</p> | <p><b>D-08</b></p> <p>FLANGE BOMBA COMB. VW/BRAS./KOMBI</p> <p>401273011 - MATERIAL: BAQUELITE</p>    |
| <p><b>D-09</b></p> <p>TERMINAL VELA COMUM PRETO</p> <p>MATERIAL: BAQUELITE</p>              | <p><b>D-10</b></p> <p>TERMINAL VELA SUPRESSIVO MARROM/PRETO</p> <p>MATERIAL: BAQUELITE</p> | <p><b>D-11</b></p> <p>BASE CHT 460 TODO VASADO</p> <p>4075078630 - MATERIAL: BAQUELITE</p>    | <p><b>D-12</b></p> <p>BAQUELITE DA INJEÇ. ELET. TBI PASSARINHO</p> <p>MATERIAL: BAQUELITE</p>         |

**210 CALÇO, FLANGE E TERMINAL**

|   |  |   |  |
|---|--|---|--|
| <p><b>D-13</b></p>  <p>FLANGE BOMBA COMBUSTÍVEL PASSAT 1.8</p> <p>56127301 - MATERIAL: BAQUELITE</p> | <p><b>D-14</b></p>  <p>BASE CHT 460 COM 2 FUROS</p> <p>MATERIAL: BAQUELITE</p>      | <p><b>D-15</b></p>  <p>FLANGE BOMBA COMBUSTÍVEL SANTANA</p> <p>35127301 - MATERIAL: BAQUELITE</p> | <p><b>D-16</b></p>  <p>BASE WEBER 40 - ESPESSURA 12 MM</p> <p>MATERIAL: BAQUELITE</p>             |
| <p><b>D-17</b></p>  <p>BASE TLDF</p> <p>MATERIAL: BAQUELITE</p>                                      | <p><b>D-18</b></p>  <p>BASE CHT FIAT 460 2 FUROS</p> <p>MATERIAL: BAQUELITE</p>     | <p><b>D-19</b></p>  <p>BASE WEBER 40 - ESPESSURA 16 MM</p> <p>MATERIAL: BAQUELITE</p>             | <p><b>D-20</b></p>  <p>BASE CHEVETTE 1.6</p> <p>MATERIAL: BAQUELITE</p>                           |
| <p><b>D-21</b></p>  <p>BASE FIAT 460</p> <p>MATERIAL: BAQUELITE</p>                                 | <p><b>D-22</b></p>  <p>BANDEJA FIAT UNO</p> <p>MATERIAL: BAQUELITE</p>             | <p><b>D-23</b></p>  <p>BASE WEBER 40 - ESPESSURA 4 MM</p> <p>MATERIAL: BAQUELITE</p>             | <p><b>D-24</b></p>  <p>BASE CHT FIAT 460 VAZADO</p> <p>MATERIAL: BAQUELITE</p>                   |
| <p><b>D-25</b></p>  <p>BASE FIAT UNO MILLE</p> <p>MATERIAL: BAQUELITE</p>                          | <p><b>D-26</b></p>  <p>FLANGE BOMBA COMB. TIPO 1.6</p> <p>MATERIAL: BAQUELITE</p> | <p><b>D-27</b></p>  <p>FLANGE BOMBA COMB. TIPO 1.6 ARGENTINO</p> <p>MATERIAL: BAQUELITE</p>     | <p><b>D-28</b></p>  <p>CALÇO DA INJEÇÃO ELETRONICA FIAT TIPO 1.6</p> <p>MATERIAL: BAQUELITE</p> |

**215 CALÇO P/ CARBURADOR**

|  |  |   |  |
|--|--|---|--|
| <p><b>400175/A</b></p>  <p>FLANGE DO CARB. 2E (ALUMÍNIO)(EMBORRACHADA)</p>          | <p><b>400175/B</b></p>  <p>FLANGE DO CARB. 2E (METAL)(EMBORRACHADA)</p> | <p><b>400175/C</b></p>  <p>CALÇO CARB. SANTANA 2E/3E ( ÓCULOS )</p> <p>PAPEL HIDRÁULICO</p> | <p><b>400450/B</b></p>  <p>FLANGE DO CARB. 450 (MINI PROGRESSIVO)(EMBORRACHADA)</p> |
| <p><b>400450/C</b></p>  <p>CALÇO CARB. MINI PROGRESSIVO</p> <p>PAPEL HIDRÁULICO</p> | <p><b>400460/B</b></p>  <p>FLANGE DO CARB. CHT(EMBORRACHADA)</p>        | <p><b>400460/C</b></p>  <p>CALÇO CARB. CHT FORD (ABERTO)</p> <p>PAPEL HIDRÁULICO</p>        | <p><b>400460/F</b></p>  <p>CALÇO CARB. CHT FORD</p> <p>PAPEL HIDRÁULICO</p>         |

**215 CALÇO P/ CARBURADOR**

|   |  |  |  |
|---|--|--|--|
| <p><b>400495/B</b></p> <p>FLANGE DO CARB. TLDZ (EMBORRACHADA)</p> | <p><b>400495/C</b></p> <p>CALÇO CARB. TLDZ</p> <p>PAPEL HIDRÁULICO</p> |  |  |
|---|--|--|--|

**220 PEÇAS DIVERSAS CARBURADOR**

|  |  |  |   |
|--|--|--|---|
| <p><b>303.056</b></p> <p>ROLDANA NYLON CARB. TLDZ</p>                            | <p><b>303.057</b></p> <p>ROLDANA DE NYLON CARB 450 MINI PROGRESSIVO</p>        | <p><b>303.078</b></p> <p>TRAVA "R" PARA HASTE DO CARBURADOR</p>                                    | <p><b>303.079</b></p> <p>CUPILHA PARA HASTE DO CARBURADOR</p> <p>TAMANHO PEQUENA</p>  |
| <p><b>303.1004</b></p> <p>FILT.COMB. 1004 - ELEMENTO FILTRANTE</p>               | <p><b>303.101305</b></p> <p>TELA FILTRANTE CARB. 2E7/3E7 FORD/GM/WW</p>        | <p><b>303.175/T</b></p> <p>TRAVA LATAO CARB. 2E7</p>   | <p><b>320.050/B</b></p> <p>BORR.BOCAL DO CARBURADOR SOLEX DUPLO H-34</p>  |
| <p><b>320.130/B</b></p> <p>BORR.BOCAL DO CARBURADOR BLFA SOLEX DUPLO - TODOS</p> | <p><b>320.175/A</b></p> <p>BORR. BOCAL DO CARBURADOR SOLEX DUPLO 2E/3E</p>     | <p><b>320.228/B</b></p> <p>BORR. BOCAL DO CARBURADOR DFV (CORCEL ANTIGO).. WEBER SIMPLÉS TODOS</p> | <p><b>320.450/B</b></p> <p>BORR. BOCAL DO CARBURADOR WEBER 450 MINI-PROGRES</p>   |
| <p><b>320.460/B</b></p> <p>VALVULA DE RETENCAO CARB. 460 NBR</p>                 | <p><b>320.460/BI</b></p> <p>BORR. BOCAL DO CARBURADOR CHT WEBER INFERIOR</p>   | <p><b>320.460/BS</b></p> <p>BORR. BOCAL DO CARBURADOR CHT WEBER SUPERIOR</p>                       | <p><b>320.460/PA</b></p> <p>BUCHA ISOLADORA DO PEDAL DO ACELERADOR GOL PARATI SANTANA QUANTUM E VERSAILLES</p> <p>305.721.559.4</p> |
| <p><b>320.489/C</b></p> <p>AUTODROMO TOWNER NBR</p>                              | <p><b>320.495/B</b></p> <p>BORR.BOCAL DO CARBURADOR TLDZ WEBER DUPLO TODOS</p> | <p><b>320.739/A</b></p> <p>ANEL DE VEDACAO PARA EIXO CARBURADOR WEBER</p>                          | <p><b>350.495/F</b></p> <p>BUCHA DE VITON 495 TLDZ (BARRILZINHO)</p>  |

**225 MOLA**

**225 MOLA**

|   |  |   |  |
|---|--|---|--|
| <p><b>T-976</b></p> <p>MOLA DIAFRAGMA 3E</p>          | <p><b>T-977</b></p> <p>MOLA VÁL.MÁX. 2E / 3E</p>               | <p><b>T-979</b></p> <p>MOLA DO GOL 1300 AR</p>      | <p><b>T-980</b></p> <p>MOLA DO FIAT</p>          |
| <p><b>T-981</b></p> <p>MOLA DO PISTÃO FORÇA</p>       | <p><b>T-982</b></p> <p>MOLA DO PISTÃO</p>                      | <p><b>T-992</b></p> <p>MOLA ACELERAÇÃO BRASÍLIA</p> | <p><b>T-993</b></p> <p>MOLA ACELERAÇÃO FUSCA</p> |
| <p><b>T-994</b></p> <p>MOLA VÁL.MÁX.DO CHT</p>        | <p><b>T-995</b></p> <p>MOLA DIAFRAGMA DO BLFA</p>              | <p><b>T-996</b></p> <p>MOLA DIAFRAGMA DO 2E</p>     | <p><b>T-997</b></p> <p>MOLA DIAFRAGMA DO CHT</p> |
| <p><b>T-998</b></p> <p>MOLA DIAFRAGMA DA BRASÍLIA</p> | <p><b>T-999</b></p> <p>MOLA DIAFRAGMA DO FUSCA</p> <p>7927</p> |   |  |

**230 BOIA**

|   |  |   |   |
|---|--|---|---|
| <p><b>T-958</b></p> <p>BÓIA TRAFIC / F.1000 (HOLLEY ARGENTINO)</p>  | <p><b>T-959</b></p> <p>BÓIA MOTORKRAT 302-MOTOR V-8</p>              | <p><b>T-960</b></p> <p>BÓIA BLFA (BROSOL)</p> <p>30074</p>  | <p><b>T-961</b></p> <p>BÓIA FIAT 147 (BROSOL)</p> <p>32139</p>  |
| <p><b>T-962</b></p> <p>BÓIA JEEP/RURAL/F75 (40 EIS)</p> <p>4005</p> | <p><b>T-963</b></p> <p>BÓIA SOLEÇÃO (34SEIE GRANDE)</p> <p>34633</p> | <p><b>T-964</b></p> <p>BÓIA WEBER 40/44/48 (PREPARAÇÃO)</p> | <p><b>T-965</b></p> <p>BÓIA GALAXIE (DFV-444)</p> <p>400648</p> |







**230 BOIA**

|  |  |  |  |
|--|--|--|--|
| <p><b>T-966</b></p> <p>BÓIA TLDZ (495)</p> <p>403859</p>               | <p><b>T-967</b></p> <p>BÓIA CHT (460)</p> <p>403888</p>                | <p><b>T-968</b></p> <p>BÓIA FIAT 190</p> <p>403886</p>                               | <p><b>T-969</b></p> <p>BÓIA TOWNER</p> <p>10013628</p>                 |
| <p><b>T-970</b></p> <p>BÓIA MINI PROGRESSIVO (450)</p> <p>403558</p>   | <p><b>T-971</b></p> <p>BÓIA OPALA 2.500 (40 DEIS)</p> <p>40650</p>     | <p><b>T-972</b></p> <p>BÓIA FORD / GM (34 SEIE BARILZINHO)</p> <p>3474/3485/3494</p> | <p><b>T-973</b></p> <p>BÓIA CHEVETTE PDSI (BARILZINHO)</p> <p>3231</p> |
| <p><b>T-974</b></p> <p>BÓIA OPALA 6CC (446)</p> <p>400759</p>          | <p><b>T-975</b></p> <p>BÓIA 2E / 3E</p> <p>20037</p>                   | <p><b>T-983</b></p> <p>BÓIA KOMBI MODERNA 1.600 (32 PDSI)</p> <p>32176</p>           | <p><b>T-984</b></p> <p>BÓIA PASSAT (35 PDSI)</p> <p>3508</p>           |
| <p><b>T-985</b></p> <p>BÓIA CHEVETTE/OPALA (DFV-228)</p> <p>400647</p> | <p><b>T-986</b></p> <p>BÓIA MONZA/FIAT (35 ALFA-1)</p> <p>35017</p>    | <p><b>T-987</b></p> <p>BÓIA CHEVETTE (35 PDSI)</p> <p>3582</p>                       | <p><b>T-988</b></p> <p>BÓIA BRASÍLIA (32/34 PDSI)</p> <p>32172</p>     |
| <p><b>T-989</b></p> <p>BÓIA FUSCA (30 PIC)</p> <p>3006</p>             | <p><b>T-989CX</b></p> <p>BÓIA FUSCA (30 PIC) COM CAIXA</p> <p>3006</p> |  |  |

**235 CORRETOR DE AR SOLEX (CATE) \*EMBALAGEM 10UN PREÇO UN\***

|   |  |   |   |
|---|--|---|---|
| <p><b>52.761/090</b></p> <p>CORRETOR DE AR SOLEX CATE<br/>CALIBRAGEM 90</p> <p>112.068/90</p> | <p><b>52.761/110</b></p> <p>CORRETOR DE AR SOLEX CATE<br/>CALIBRAGEM 90</p> <p>112.068/110</p> | <p><b>52.761/120</b></p> <p>CORRETOR DE AR SOLEX CATE<br/>CALIBRAGEM 120</p> <p>112.068/120</p> | <p><b>52.761/125</b></p> <p>CORRETOR DE AR SOLEX CATE<br/>CALIBRAGEM 125</p> <p>112.063/125</p> |
|---|--|---|---|

**235 CORRETOR DE AR SOLEX (CATE) \*EMBALAGEM 10UN PREÇO UN\***

|   |   |  |   |
|---|---|--|---|
| <p><b>52.761/130</b></p>  <p>CORRETOR DE AR SOLEX CATE<br/>CALIBRAGEM 130</p> <p>112.069/130</p>             | <p><b>52.761/135</b></p>  <p>CORRETOR DE AR SOLEX CATE<br/>CALIBRAGEM 135</p> <p>112.067/135</p>           | <p><b>52.761/140</b></p>  <p>CORRETOR DE AR SOLEX CATE<br/>CALIBRAGEM 140</p> <p>112.070/140</p>         | <p><b>52.761/145</b></p>  <p>CORRETOR DE AR SOLEX CATE<br/>CALIBRAGEM 145</p> <p>112.064/145</p>         |
| <p><b>53.156</b></p>  <p>CORRETOR DE AR SOLEX 2E7/3E GM 6CC<br/>89/92 1º CORPO GAS</p> <p>C-85</p>           | <p><b>53.159</b></p>  <p>CORRETOR DE AR SOLEX 3E7 GM 6CC 92 1º<br/>CORPO ALC</p> <p>D-80F</p>              | <p><b>53.160</b></p>  <p>CORRETOR DE AR SOLEX 3E7 GM 4CC 89/...<br/>1º CORPO ALC.</p> <p>D-80G</p>       | <p><b>53.163</b></p>  <p>CORRETOR DE AR CARB.SOLEX 2E7 VW<br/>88/89 1º CORPO ALC</p> <p>H-110</p>        |
| <p><b>53.164</b></p>  <p>CORRETOR DE AR SOLEX 2E7/3E VW/FORD<br/>91/93 1.8/2.0 1º CORPO ALC</p> <p>J-85</p> | <p><b>53.171</b></p>  <p>CORRETOR DE AR SOLEX 2E7 VW/FORD<br/>88/91 1.8/2.0 1º CORPO GAS</p> <p>X-100</p> | <p><b>53.201</b></p>  <p>CORRETOR DE AR SOLEX 3E7 VW/FORD 2.0<br/>89/93 2º CORPO ALC.</p> <p>D-105F</p> | <p><b>53.202</b></p>  <p>CORRETOR DE AR SOLEX 2E7 VW/FORD 2.0<br/>93/... 2º CORPO ALC</p> <p>D-105G</p> |

**240 CORRETOR DE AR SOLEX (CARS) \*EMBALAGEM 10UN PREÇO UN\***

|  |  |   |  |
|--|--|---|--|
| <p><b>52.771/060</b></p>  <p>CORRETOR DE AR SOLEX CARS<br/>CALIBRAGEM 60</p> <p>11.065/60</p>   | <p><b>52.771/062,5</b></p>  <p>CORRETOR DE AR SOLEX CARS<br/>CALIBRAGEM 62,5</p> <p>11.065/62,5</p> | <p><b>52.771/065</b></p>  <p>CORRETOR DE AR SOLEX CARS<br/>CALIBRAGEM 65</p> <p>11.065/65</p>   | <p><b>52.771/067,5</b></p>  <p>CORRETOR DE AR SOLEX CARS<br/>CALIBRAGEM 67,5</p> <p>11.065/67,5</p> |
| <p><b>52.771/070</b></p>  <p>CORRETOR DE AR SOLEX CARS<br/>CALIBRAGEM 70</p> <p>11.065/70</p>   | <p><b>52.771/075</b></p>  <p>CORRETOR DE AR SOLEX CARS<br/>CALIBRAGEM 75</p> <p>11.065/75</p>       | <p><b>52.771/080</b></p>  <p>CORRETOR DE AR SOLEX CARS<br/>CALIBRAGEM 80</p> <p>11.065/80</p>   | <p><b>52.771/090</b></p>  <p>CORRETOR DE AR SOLEX CARS<br/>CALIBRAGEM 90</p> <p>11.065/90</p>       |
| <p><b>52.771/100</b></p>  <p>CORRETOR DE AR SOLEX CARS<br/>CALIBRAGEM 100</p> <p>11.065/100</p> | <p><b>52.771/105</b></p>  <p>CORRETOR DE AR SOLEX CARS<br/>CALIBRAGEM 105</p> <p>11.065/105</p>     | <p><b>52.771/110</b></p>  <p>CORRETOR DE AR SOLEX CARS<br/>CALIBRAGEM 110</p> <p>11.065/110</p> | <p><b>52.771/115</b></p>  <p>CORRETOR DE AR SOLEX CARS<br/>CALIBRAGEM 115</p> <p>11.065/115</p>     |

**240 CORRETOR DE AR SOLEX (CARS) \*EMBALAGEM 10UN PREÇO UN\***

|  |  |   |  |
|--|--|---|--|
| <p><b>52.771/120</b></p>  <p>CORRETOR DE AR SOLEX CARS<br/>CALIBRAGEM 120</p> <p>11.065/120</p>   | <p><b>52.771/125</b></p>  <p>CORRETOR DE AR SOLEX CARS<br/>CALIBRAGEM 125</p> <p>11.065/125</p>   | <p><b>52.771/130</b></p>  <p>CORRETOR DE AR SOLEX CARS<br/>CALIBRAGEM 130</p> <p>11.065/130</p>   | <p><b>52.771/135</b></p>  <p>CORRETOR DE AR SOLEX CARS<br/>CALIBRAGEM 135</p> <p>11.065/135</p>   |
| <p><b>52.771/140</b></p>  <p>CORRETOR DE AR SOLEX CARS<br/>CALIBRAGEM 140</p> <p>11.065/140</p>   | <p><b>52.771/145</b></p>  <p>CORRETOR DE AR SOLEX CARS<br/>CALIBRAGEM 145</p> <p>11.065/145</p>   | <p><b>52.771/150</b></p>  <p>CORRETOR DE AR SOLEX CARS<br/>CALIBRAGEM 150</p> <p>11.065/150</p>   | <p><b>52.771/155</b></p>  <p>CORRETOR DE AR SOLEX CARS<br/>CALIBRAGEM 155</p> <p>11.065/155</p>   |
| <p><b>52.771/160</b></p>  <p>CORRETOR DE AR SOLEX CARS<br/>CALIBRAGEM 160</p> <p>11.065/160</p>  | <p><b>52.771/165</b></p>  <p>CORRETOR DE AR SOLEX CARS<br/>CALIBRAGEM 165</p> <p>11.065/165</p>  | <p><b>52.771/170</b></p>  <p>CORRETOR DE AR SOLEX CARS<br/>CALIBRAGEM 170</p> <p>11.065/170</p>  | <p><b>52.771/175</b></p>  <p>CORRETOR DE AR SOLEX CARS<br/>CALIBRAGEM 175</p> <p>11.065/175</p>  |
| <p><b>52.771/180</b></p>  <p>CORRETOR DE AR SOLEX CARS<br/>CALIBRAGEM 180</p> <p>11.065/180</p> | <p><b>52.771/185</b></p>  <p>CORRETOR DE AR SOLEX CARS<br/>CALIBRAGEM 185</p> <p>11.065/185</p> | <p><b>52.771/190</b></p>  <p>CORRETOR DE AR SOLEX CARS<br/>CALIBRAGEM 190</p> <p>11.065/190</p> | <p><b>52.771/195</b></p>  <p>CORRETOR DE AR SOLEX CARS<br/>CALIBRAGEM 195</p> <p>11.065/195</p> |

**245 CORRETOR DE AR WEBER (CARHT) \*EMBALAGEM 10UN PREÇO UN\***

|   |   |  |   |
|---|---|--|---|
| <p><b>52.710/080</b></p>  <p>CORRETOR DE AR DUPLO WEBER 460<br/>CALIBRAGEM 80</p> <p>323.008.02</p>  | <p><b>52.710/085</b></p>  <p>CORRETOR DE AR DUPLO WEBER 460<br/>CALIBRAGEM 85</p> <p>323.008.52</p>  | <p><b>52.710/090</b></p>  <p>CORRETOR DE AR DUPLO WEBER 460<br/>CALIBRAGEM 90</p> <p>323.009.02</p>  | <p><b>52.710/095</b></p>  <p>CORRETOR DE AR DUPLO WEBER 460<br/>CALIBRAGEM 95</p> <p>323.009.52</p>  |
| <p><b>52.710/100</b></p>  <p>CORRETOR DE AR DUPLO WEBER 460<br/>CALIBRAGEM 100</p> <p>323.010.02</p> | <p><b>52.710/105</b></p>  <p>CORRETOR DE AR DUPLO WEBER 460<br/>CALIBRAGEM 105</p> <p>323.010.52</p> | <p><b>52.710/110</b></p>  <p>CORRETOR DE AR DUPLO WEBER 460<br/>CALIBRAGEM 110</p> <p>323.011.02</p> | <p><b>52.710/115</b></p>  <p>CORRETOR DE AR DUPLO WEBER 460<br/>CALIBRAGEM 115</p> <p>323.011.52</p> |

**245 CORRETOR DE AR WEBER (CARCHT) \*EMBALAGEM 10UN PREÇO UN\***

|   |   |  |   |
|---|---|--|---|
| <p><b>52.710/120</b></p>  <p>CORRETOR DE AR DUPLO WEBER 460<br/>CALIBRAGEM 120</p> <p>323.012.02</p>   | <p><b>52.710/125</b></p>  <p>CORRETOR DE AR DUPLO WEBER 460<br/>CALIBRAGEM 125</p> <p>323.012.52</p>   | <p><b>52.710/130</b></p>  <p>CORRETOR DE AR DUPLO WEBER 460<br/>CALIBRAGEM 130</p> <p>323.013.02</p>   | <p><b>52.710/135</b></p>  <p>CORRETOR DE AR DUPLO WEBER 460<br/>CALIBRAGEM 135</p> <p>323.013.52</p>   |
| <p><b>52.710/140</b></p>  <p>CORRETOR DE AR DUPLO WEBER 460<br/>CALIBRAGEM 140</p> <p>323.014.02</p>   | <p><b>52.710/145</b></p>  <p>CORRETOR DE AR DUPLO WEBER 460<br/>CALIBRAGEM 145</p> <p>323.014.52</p>   | <p><b>52.710/150</b></p>  <p>CORRETOR DE AR DUPLO WEBER 460<br/>CALIBRAGEM 150</p> <p>323.015.02</p>   | <p><b>52.710/155</b></p>  <p>CORRETOR DE AR DUPLO WEBER 460<br/>CALIBRAGEM 155</p> <p>323.015.52</p>   |
| <p><b>52.710/160</b></p>  <p>CORRETOR DE AR DUPLO WEBER 460<br/>CALIBRAGEM 160</p> <p>323.016.02</p>   | <p><b>52.710/165</b></p>  <p>CORRETOR DE AR DUPLO WEBER 460<br/>CALIBRAGEM 165</p> <p>323.016.52</p>   | <p><b>52.710/170</b></p>  <p>CORRETOR DE AR DUPLO WEBER 460<br/>CALIBRAGEM 170</p> <p>323.017.02</p>   | <p><b>52.710/175</b></p>  <p>CORRETOR DE AR DUPLO WEBER 460<br/>CALIBRAGEM 175</p> <p>323.017.52</p>   |
| <p><b>52.710/180</b></p>  <p>CORRETOR DE AR DUPLO WEBER 460<br/>CALIBRAGEM 180</p> <p>323.018.02</p> | <p><b>52.710/185</b></p>  <p>CORRETOR DE AR DUPLO WEBER 460<br/>CALIBRAGEM 185</p> <p>323.018.52</p> | <p><b>52.710/190</b></p>  <p>CORRETOR DE AR DUPLO WEBER 460<br/>CALIBRAGEM 190</p> <p>323.019.02</p> | <p><b>52.710/195</b></p>  <p>CORRETOR DE AR DUPLO WEBER 460<br/>CALIBRAGEM 195</p> <p>323.019.52</p> |
| <p><b>52.710/200</b></p>  <p>CORRETOR DE AR DUPLO WEBER 460<br/>CALIBRAGEM 200</p> <p>323.020.02</p> | <p><b>52.710/205</b></p>  <p>CORRETOR DE AR DUPLO WEBER 460<br/>CALIBRAGEM 205</p> <p>323.020.52</p> | <p><b>52.710/210</b></p>  <p>CORRETOR DE AR DUPLO WEBER 460<br/>CALIBRAGEM 210</p> <p>323.021.02</p> | <p><b>52.710/215</b></p>  <p>CORRETOR DE AR DUPLO WEBER 460<br/>CALIBRAGEM 215</p> <p>323.021.52</p> |
| <p><b>52.710/220</b></p>  <p>CORRETOR DE AR DUPLO WEBER 460<br/>CALIBRAGEM 220</p> <p>323.022.02</p> | <p><b>52.710/230</b></p>  <p>CORRETOR DE AR DUPLO WEBER 460<br/>CALIBRAGEM 230</p> <p>323.023.02</p> | <p><b>52.710/235</b></p>  <p>CORRETOR DE AR DUPLO WEBER 460<br/>CALIBRAGEM 235</p> <p>323.023.52</p> |   |

**250 CORRETOR DE AR WEBER (RPMP) \*EMBALAGEM 10UN PREÇO UN\***



















**250 CORRETOR DE AR WEBER (RPMP) \*EMBALAGEM 10UN PREÇO UN\***

|  |  |   |  |
|--|--|---|--|
| <p><b>52.851/080</b></p>  <p>CORRETOR DE AR WEBER 190/450/495<br/>RPMP CALIBRAGEM 80</p> <p>314.908.02</p>    | <p><b>52.851/090</b></p>  <p>CORRETOR DE AR WEBER 190/450/495<br/>RPMP CALIBRAGEM 90</p> <p>314.909.02</p>    | <p><b>52.851/095</b></p>  <p>CORRETOR DE AR WEBER 190/450/495<br/>RPMP CALIBRAGEM 95</p> <p>314.909.52</p>    | <p><b>52.851/100</b></p>  <p>CORRETOR DE AR WEBER 190/450/495<br/>RPMP CALIBRAGEM 100</p> <p>314.910.02</p>   |
| <p><b>52.851/105</b></p>  <p>CORRETOR DE AR WEBER 190/450/495<br/>RPMP CALIBRAGEM 105</p> <p>314.910.52</p>   | <p><b>52.851/110</b></p>  <p>CORRETOR DE AR WEBER 190/450/495<br/>RPMP CALIBRAGEM 110</p> <p>314.911.02</p>   | <p><b>52.851/115</b></p>  <p>CORRETOR DE AR WEBER 190/450/495<br/>RPMP CALIBRAGEM 115</p> <p>314.911.52</p>   | <p><b>52.851/120</b></p>  <p>CORRETOR DE AR WEBER 190/450/495<br/>RPMP CALIBRAGEM 120</p> <p>314.912.02</p>   |
| <p><b>52.851/125</b></p>  <p>CORRETOR DE AR WEBER 190/450/495<br/>RPMP CALIBRAGEM 125</p> <p>314.912.52</p>   | <p><b>52.851/130</b></p>  <p>CORRETOR DE AR WEBER 190/450/495<br/>RPMP CALIBRAGEM 130</p> <p>314.913.02</p>   | <p><b>52.851/135</b></p>  <p>CORRETOR DE AR WEBER 190/450/495<br/>RPMP CALIBRAGEM 135</p> <p>314.913.52</p>   | <p><b>52.851/140</b></p>  <p>CORRETOR DE AR WEBER 190/450/495<br/>RPMP CALIBRAGEM 140</p> <p>314.914.02</p>   |
| <p><b>52.851/145</b></p>  <p>CORRETOR DE AR WEBER 190/450/495<br/>RPMP CALIBRAGEM 145</p> <p>314.914.52</p> | <p><b>52.851/150</b></p>  <p>CORRETOR DE AR WEBER 190/450/495<br/>RPMP CALIBRAGEM 150</p> <p>314.915.02</p> | <p><b>52.851/155</b></p>  <p>CORRETOR DE AR WEBER 190/450/495<br/>RPMP CALIBRAGEM 155</p> <p>314.915.52</p> | <p><b>52.851/160</b></p>  <p>CORRETOR DE AR WEBER 190/450/495<br/>RPMP CALIBRAGEM 160</p> <p>314.916.02</p> |
| <p><b>52.851/165</b></p>  <p>CORRETOR DE AR WEBER 190/450/495<br/>RPMP CALIBRAGEM 165</p> <p>314.916.52</p> | <p><b>52.851/170</b></p>  <p>CORRETOR DE AR WEBER 190/450/495<br/>RPMP CALIBRAGEM 170</p> <p>314.917.02</p> | <p><b>52.851/175</b></p>  <p>CORRETOR DE AR WEBER 190/450/495<br/>RPMP CALIBRAGEM 175</p> <p>314.917.52</p> | <p><b>52.851/180</b></p>  <p>CORRETOR DE AR WEBER 190/450/495<br/>RPMP CALIBRAGEM 180</p> <p>314.918.02</p> |
| <p><b>52.851/185</b></p>  <p>CORRETOR DE AR WEBER 190/450/495<br/>RPMP CALIBRAGEM 185</p> <p>314.918.52</p> | <p><b>52.851/190</b></p>  <p>CORRETOR DE AR WEBER 190/450/495<br/>RPMP CALIBRAGEM 190</p> <p>314.919.02</p> | <p><b>52.851/195</b></p>  <p>CORRETOR DE AR WEBER 190/450/495<br/>RPMP CALIBRAGEM 195</p> <p>314.919.52</p> | <p><b>52.851/200</b></p>  <p>CORRETOR DE AR WEBER 190/450/495<br/>RPMP CALIBRAGEM 200</p> <p>314.920.02</p> |

















**250 CORRETOR DE AR WEBER (RPMP) \*EMBALAGEM 10UN PREÇO UN\***

|  |  |   |  |
|--|--|---|--|
| <p><b>52.851/205</b></p>  <p>CORRETOR DE AR WEBER 190/450/495<br/>RPMP CALIBRAGEM 205</p> <p>314.920.52</p> | <p><b>52.851/210</b></p>  <p>CORRETOR DE AR WEBER 190/450/495<br/>RPMP CALIBRAGEM 210</p> <p>314.921.02</p> | <p><b>52.851/215</b></p>  <p>CORRETOR DE AR WEBER 190/450/495<br/>RPMP CALIBRAGEM 215</p> <p>314.921.52</p> | <p><b>52.851/220</b></p>  <p>CORRETOR DE AR WEBER 190/450/495<br/>RPMP CALIBRAGEM 220</p> <p>314.922.02</p> |
| <p><b>52.851/225</b></p>  <p>CORRETOR DE AR WEBER 190/450/495<br/>RPMP CALIBRAGEM 225</p> <p>314.922.52</p> | <p><b>52.851/230</b></p>  <p>CORRETOR DE AR WEBER 190/450/495<br/>RPMP CALIBRAGEM 230</p> <p>314.923.02</p> |   |  |

**255 GICLEUR PRINCIPAL CHT (GPCHT) \*EMBALAGEM 10UN PREÇO UN\***

|   |   |  |   |
|---|---|--|---|
| <p><b>52.251/080</b></p>  <p>GICLEUR PRINCIPAL DUPLO WEBER 460<br/>CHT .. GPCHT CALIBRAGEM 80</p> <p>323.108.02</p>   | <p><b>52.251/082</b></p>  <p>GICLEUR PRINCIPAL DUPLO WEBER 460<br/>CHT .. GPCHT CALIBRAGEM 82</p> <p>323.108.22</p>   | <p><b>52.251/085</b></p>  <p>GICLEUR PRINCIPAL DUPLO WEBER 460<br/>CHT .. GPCHT CALIBRAGEM 85</p> <p>323.108.52</p>   | <p><b>52.251/087</b></p>  <p>GICLEUR PRINCIPAL DUPLO WEBER 460<br/>CHT .. GPCHT CALIBRAGEM 87</p> <p>323.108.72</p>   |
| <p><b>52.251/090</b></p>  <p>GICLEUR PRINCIPAL DUPLO WEBER 460<br/>CHT .. GPCHT CALIBRAGEM 90</p> <p>323.109.02</p>  | <p><b>52.251/092</b></p>  <p>GICLEUR PRINCIPAL DUPLO WEBER 460<br/>CHT .. GPCHT CALIBRAGEM 92</p> <p>323.109.22</p>  | <p><b>52.251/095</b></p>  <p>GICLEUR PRINCIPAL DUPLO WEBER 460<br/>CHT .. GPCHT CALIBRAEM 95</p> <p>323.109.52</p>   | <p><b>52.251/097</b></p>  <p>GICLEUR PRINCIPAL DUPLO WEBER 460<br/>CHT .. GPCHT CALIBRAGEM 97</p> <p>323.109.72</p>  |
| <p><b>52.251/100</b></p>  <p>GICLEUR PRINCIPAL DUPLO WEBER 460<br/>CHT .. GPCHT CALIBRAGEM 100</p> <p>323.110.02</p> | <p><b>52.251/102</b></p>  <p>GICLEUR PRINCIPAL DUPLO WEBER 460<br/>CHT .. GPCHT CALIBRAGEM 102</p> <p>323.110.22</p> | <p><b>52.251/105</b></p>  <p>GICLEUR PRINCIPAL DUPLO WEBER 460<br/>CHT .. GPCHT CALIBRAGEM 105</p> <p>323.110.52</p> | <p><b>52.251/107</b></p>  <p>GICLEUR PRINCIPAL DUPLO WEBER 460<br/>CHT .. GPCHT CALIBRAGEM 107</p> <p>323.110.72</p> |
| <p><b>52.251/110</b></p>  <p>GICLEUR PRINCIPAL DUPLO WEBER 460<br/>CHT .. GPCHT CALIBRAGEM 110</p> <p>323.111.02</p> | <p><b>52.251/112</b></p>  <p>GICLEUR PRINCIPAL DUPLO WEBER 460<br/>CHT .. GPCHT CALIBRAGEM 112</p> <p>323.111.22</p> | <p><b>52.251/115</b></p>  <p>GICLEUR PRINCIPAL DUPLO WEBER 460<br/>CHT .. GPCHT CALIBRAGEM 115</p> <p>323.111.52</p> | <p><b>52.251/117</b></p>  <p>GICLEUR PRINCIPAL DUPLO WEBER 460<br/>CHT .. GPCHT CALIBRAGEM 117</p> <p>323.111.72</p> |

**255 GICLEUR PRINCIPAL CHT (GPCHT) \*EMBALAGEM 10UN PREÇO UN\***

|   |   |  |   |
|---|---|--|---|
| <p><b>52.251/120</b></p>  <p>GICLEUR PRINCIPAL DUPLO WEBER 460<br/>CHT .. GPCHT CALIBRAGEM 120</p> <p>323.112.02</p>   | <p><b>52.251/122</b></p>  <p>GICLEUR PRINCIPAL DUPLO WEBER 460<br/>CHT .. GPCHT CALIBRAGEM 122</p> <p>323.112.22</p>   | <p><b>52.251/125</b></p>  <p>GICLEUR PRINCIPAL DUPLO WEBER 460<br/>CHT .. GPCHT CALIBRAGEM 125</p> <p>323.112.52</p>   | <p><b>52.251/127</b></p>  <p>GICLEUR PRINCIPAL DUPLO WEBER 460<br/>CHT .. GPCHT CALIBRAGEM 127</p> <p>323.112.72</p>   |
| <p><b>52.251/130</b></p>  <p>GICLEUR PRINCIPAL DUPLO WEBER 460<br/>CHT .. GPCHT CALIBRAGEM 130</p> <p>323.113.02</p>   | <p><b>52.251/132</b></p>  <p>GICLEUR PRINCIPAL DUPLO WEBER 460<br/>CHT .. GPCHT CALIBRAGEM 132</p> <p>323.113.22</p>   | <p><b>52.251/135</b></p>  <p>GICLEUR PRINCIPAL DUPLO WEBER 460<br/>CHT .. GPCHT CALIBRAGEM 135</p> <p>323.113.52</p>   | <p><b>52.251/137</b></p>  <p>GICLEUR PRINCIPAL DUPLO WEBER 460<br/>CHT .. GPCHT CALIBRAGEM 137</p> <p>323.113.72</p>   |
| <p><b>52.251/140</b></p>  <p>GICLEUR PRINCIPAL DUPLO WEBER 460<br/>CHT .. GPCHT CALIBRAGEM 140</p> <p>323.114.02</p>   | <p><b>52.251/142</b></p>  <p>GICLEUR PRINCIPAL DUPLO WEBER 460<br/>CHT .. GPCHT CALIBRAGEM 142</p> <p>323.114.22</p>   | <p><b>52.251/145</b></p>  <p>GICLEUR PRINCIPAL DUPLO WEBER 460<br/>CHT .. GPCHT CALIBRAGEM 145</p> <p>323.114.52</p>   | <p><b>52.251/147</b></p>  <p>GICLEUR PRINCIPAL DUPLO WEBER 460<br/>CHT .. GPCHT CALIBRAGEM 147</p> <p>323.114.72</p>   |
| <p><b>52.251/150</b></p>  <p>GICLEUR PRINCIPAL DUPLO WEBER 460<br/>CHT .. GPCHT CALIBRAGEM 150</p> <p>323.115.02</p> | <p><b>52.251/152</b></p>  <p>GICLEUR PRINCIPAL DUPLO WEBER 460<br/>CHT .. GPCHT CALIBRAGEM 152</p> <p>323.115.22</p> | <p><b>52.251/155</b></p>  <p>GICLEUR PRINCIPAL DUPLO WEBER 460<br/>CHT .. GPCHT CALIBRAGEM 155</p> <p>323.115.52</p> | <p><b>52.251/157</b></p>  <p>GICLEUR PRINCIPAL DUPLO WEBER 460<br/>CHT .. GPCHT CALIBRAGEM 157</p> <p>323.115.72</p> |
| <p><b>52.251/160</b></p>  <p>GICLEUR PRINCIPAL DUPLO WEBER 460<br/>CHT .. GPCHT CALIBRAGEM 160</p> <p>323.116.02</p> | <p><b>52.251/162</b></p>  <p>GICLEUR PRINCIPAL DUPLO WEBER 460<br/>CHT .. GPCHT CALIBRAGEM 162</p> <p>323.116.22</p> | <p><b>52.251/165</b></p>  <p>GICLEUR PRINCIPAL DUPLO WEBER 460<br/>CHT .. GPCHT CALIBRAGEM 165</p> <p>323.116.52</p> | <p><b>52.251/167</b></p>  <p>GICLEUR PRINCIPAL DUPLO WEBER 460<br/>CHT .. GPCHT CALIBRAGEM 167</p> <p>323.116.72</p> |
| <p><b>52.251/170</b></p>  <p>GICLEUR PRINCIPAL DUPLO WEBER 460<br/>CHT .. GPCHT CALIBRAGEM 170</p> <p>323.117.02</p> | <p><b>52.251/172</b></p>  <p>GICLEUR PRINCIPAL DUPLO WEBER 460<br/>CHT .. GPCHT CALIBRAGEM 172</p> <p>323.117.22</p> | <p><b>52.251/175</b></p>  <p>GICLEUR PRINCIPAL DUPLO WEBER 460<br/>CHT .. GPCHT CALIBRAGEM 175</p> <p>323.117.52</p> | <p><b>52.251/180</b></p>  <p>GICLEUR PRINCIPAL DUPLO WEBER 460<br/>CHT .. GPCHT CALIBRAGEM 180</p> <p>323.118.02</p> |

**255 GICLEUR PRINCIPAL CHT (GPCHT) \*EMBALAGEM 10UN PREÇO UN\***

|   |   |   |   |
|---|---|---|---|
| <p><b>52.251/185</b></p> <p>GICLEUR PRINCIPAL DUPLO WEBER 460<br/>CHT .. GPCHT CALIBRAGEM 185</p> <p>323.118.52</p> | <p><b>52.251/187</b></p> <p>GICLEUR PRINCIPAL DUPLO WEBER 460<br/>CHT .. GPCHT CALIBRAGEM 187</p> <p>323.118.72</p> | <p><b>52.251/190</b></p> <p>GICLEUR PRINCIPAL DUPLO WEBER 460<br/>CHT .. GPCHT CALIBRAGEM 190</p> <p>323.119.02</p> | <p><b>52.251/192</b></p> <p>GICLEUR PRINCIPAL DUPLO WEBER 460<br/>CHT .. GPCHT CALIBRAGEM 192</p> <p>323.119.22</p> |
| <p><b>52.251/195</b></p> <p>GICLEUR PRINCIPAL DUPLO WEBER 460<br/>CHT .. GPCHT CALIBRAGEM 195</p> <p>323.119.52</p> | <p><b>52.251/200</b></p> <p>GICLEUR PRINCIPAL DUPLO WEBER 460<br/>CHT .. GPCHT CALIBRAGEM 200</p> <p>323.120.02</p> | <p><b>52.251/210</b></p> <p>GICLEUR PRINCIPAL DUPLO WEBER 460<br/>CHT .. GPCHT CALIBRAGEM 210</p> <p>323.121.02</p> | <p><b>52.251/220</b></p> <p>GICLEUR PRINCIPAL DUPLO WEBER 460<br/>CHT .. GPCHT CALIBRAGEM 220</p> <p>323.122.02</p> |

**260 GICLEUR PRINC WEBER 228 DFV (GPDFV) \*EMBALAGEM 10UN PREÇO UN\***

|   |   |   |   |
|---|---|---|---|
| <p><b>52.351/020</b></p> <p>GICLEUR PRINCIPAL WEBER 228 ... GPDFV<br/>CALIBRAGEM 20</p> <p>300.120.32</p> | <p><b>52.351/021</b></p> <p>GICLEUR PRINCIPAL WEBER 228 ... GPDFV<br/>CALIBRAGEM 21</p> <p>300.121.32</p> | <p><b>52.351/022</b></p> <p>GICLEUR PRINCIPAL WEBER 228 ... GPDFV<br/>CALIBRAGEM 22</p> <p>300.122.32</p> | <p><b>52.351/023</b></p> <p>GICLEUR PRINCIPAL WEBER 228 ... GPDFV<br/>CALIBRAGEM 23</p> <p>300.123.32</p> |
| <p><b>52.351/024</b></p> <p>GICLEUR PRINCIPAL WEBER 228 ... GPDFV<br/>CALIBRAGEM 24</p> <p>300.124.32</p> | <p><b>52.351/025</b></p> <p>GICLEUR PRINCIPAL WEBER 228 ... GPDFV<br/>CALIBRAGEM 25</p> <p>300.125.32</p> | <p><b>52.351/026</b></p> <p>GICLEUR PRINCIPAL WEBER 228 ... GPDFV<br/>CALIBRAGEM 26</p> <p>300.126.32</p> | <p><b>52.351/027</b></p> <p>GICLEUR PRINCIPAL WEBER 228 ... GPDFV<br/>CALIBRAGEM 27</p> <p>300.127.32</p> |
| <p><b>52.351/028</b></p> <p>GICLEUR PRINCIPAL WEBER 228 ... GPDFV<br/>CALIBRAGEM 28</p> <p>300.128.32</p> | <p><b>52.351/029</b></p> <p>GICLEUR PRINCIPAL WEBER 228 ... GPDFV<br/>CALIBRAGEM 29</p> <p>300.129.32</p> | <p><b>52.351/030</b></p> <p>GICLEUR PRINCIPAL WEBER 228 ... GPDFV<br/>CALIBRAGEM 30</p> <p>300.130.32</p> | <p><b>52.351/031</b></p> <p>GICLEUR PRINCIPAL WEBER 228 ... GPDFV<br/>CALIBRAGEM 31</p> <p>300.131.32</p> |
| <p><b>52.351/032</b></p> <p>GICLEUR PRINCIPAL WEBER 228 ... GPDFV<br/>CALIBRAGEM 32</p> <p>300.132.32</p> | <p><b>52.351/033</b></p> <p>GICLEUR PRINCIPAL WEBER 228 ... GPDFV<br/>CALIBRAGEM 33</p> <p>300.133.32</p> | <p><b>52.351/034</b></p> <p>GICLEUR PRINCIPAL WEBER 228 ... GPDFV<br/>CALIBRAGEM 34</p> <p>300.134.32</p> | <p><b>52.351/035</b></p> <p>GICLEUR PRINCIPAL WEBER 228 ... GPDFV<br/>CALIBRAGEM 35</p> <p>300.135.32</p> |



**260 GICLEUR PRINC WEBER 228 DFV (GPDFV) \*EMBALAGEM 10UN PREÇO UN\***

|  |  |   |  |
|--|--|---|--|
| <p><b>52.351/135</b></p>  <p>GICLEUR PRINCIPAL WEBER 228 ... GPDFV<br/>CALIBRAGEM 135</p> <p>300.113.52</p> | <p><b>52.351/140</b></p>  <p>GICLEUR PRINCIPAL WEBER 228 ... GPDFV<br/>CALIBRAGEM 140</p> <p>300.114.02</p> | <p><b>52.351/145</b></p>  <p>GICLEUR PRINCIPAL WEBER 228 ... GPDFV<br/>CALIBRAGEM 145</p> <p>300.114.52</p> | <p><b>52.351/165</b></p>  <p>GICLEUR PRINCIPAL WEBER 228 ... GPDFV<br/>CALIBRAGEM 165</p> <p>300.116.52</p> |
|--|--|---|--|



**265 GICLEUR PRINCIPAL SOLEX ( GAPR ) \*EMBALAGEM 10UN PREÇO UN\***

|   |   |  |   |
|---|---|--|---|
| <p><b>52.101/080</b></p>  <p>GICLEUR PRINCIPAL SOLEX GAPR<br/>CALIBRAGEM 80</p> <p>13.072/80</p>           | <p><b>52.101/082</b></p>  <p>GICLEUR PRINCIPAL SOLEX GAPR<br/>CALIBRAGEM 82</p> <p>13.072/82</p>     | <p><b>52.101/085</b></p>  <p>GICLEUR PRINCIPAL SOLEX GAPR<br/>CALIBRAGEM 85</p> <p>13.072/85</p>           | <p><b>52.101/087</b></p>  <p>GICLEUR PRINCIPAL SOLEX GAPR<br/>CALIBRAGEM 87</p> <p>13.072/87</p>     |
| <p><b>52.101/090</b></p>  <p>GICLEUR PRINCIPAL SOLEX GAPR<br/>CALIBRAGEM 90</p> <p>13.072/90</p>          | <p><b>52.101/095</b></p>  <p>GICLEUR PRINCIPAL SOLEX GAPR<br/>CALIBRAGEM 95</p> <p>13.072/95</p>    | <p><b>52.101/097,5</b></p>  <p>GICLEUR PRINCIPAL SOLEX GAPR<br/>CALIBRAGEM 97,5</p> <p>13.072/97,5</p>    | <p><b>52.101/100</b></p>  <p>GICLEUR PRINCIPAL SOLEX GAPR<br/>CALIBRAGEM 100</p> <p>13.072/100</p>  |
| <p><b>52.101/102,5</b></p>  <p>GICLEUR PRINCIPAL SOLEX GAPR<br/>CALIBRAGEM 102,5</p> <p>13.072/102,5</p> | <p><b>52.101/105</b></p>  <p>GICLEUR PRINCIPAL SOLEX GAPR<br/>CALIBRAGEM 105</p> <p>13.072/105</p> | <p><b>52.101/107,5</b></p>  <p>GICLEUR PRINCIPAL SOLEX GAPR<br/>CALIBRAGEM 107,5</p> <p>13.072/107,5</p> | <p><b>52.101/110</b></p>  <p>GICLEUR PRINCIPAL SOLEX GAPR<br/>CALIBRAGEM 110</p> <p>13.072/110</p> |
| <p><b>52.101/112,5</b></p>  <p>GICLEUR PRINCIPAL SOLEX GAPR<br/>CALIBRAGEM 112,5</p> <p>13.072/112,5</p> | <p><b>52.101/115</b></p>  <p>GICLEUR PRINCIPAL SOLEX GAPR<br/>CALIBRAGEM 115</p> <p>13.072/115</p> | <p><b>52.101/117,5</b></p>  <p>GICLEUR PRINCIPAL SOLEX GAPR<br/>CALIBRAGEM 117,5</p> <p>13.072/117,5</p> | <p><b>52.101/120</b></p>  <p>GICLEUR PRINCIPAL SOLEX GAPR<br/>CALIBRAGEM 120</p> <p>13.072/120</p> |
| <p><b>52.101/122,5</b></p>  <p>GICLEUR PRINCIPAL SOLEX GAPR<br/>CALIBRAGEM 122,5</p> <p>13.072/122,5</p> | <p><b>52.101/125</b></p>  <p>GICLEUR PRINCIPAL SOLEX GAPR<br/>CALIBRAGEM 125</p> <p>13.072/125</p> | <p><b>52.101/127,5</b></p>  <p>GICLEUR PRINCIPAL SOLEX GAPR<br/>CALIBRAGEM 127,5</p> <p>13.072/127,5</p> | <p><b>52.101/130</b></p>  <p>GICLEUR PRINCIPAL SOLEX GAPR<br/>CALIBRAGEM 130</p> <p>13.072/130</p> |

**265 GICLEUR PRINCIPAL SOLEX ( GAPR ) \*EMBALAGEM 10UN PREÇO UN\***

|   |   |  |   |
|---|---|--|---|
| <p><b>52.101/132,5</b></p>  <p>GICLEUR PRINCIPAL SOLEX GAPR<br/>CALIBRAGEM 132,5</p> <p>13.072/132,5</p>   | <p><b>52.101/135</b></p>  <p>GICLEUR PRINCIPAL SOLEX GAPR<br/>CALIBRAGEM 135</p> <p>13.072/135</p>         | <p><b>52.101/137,5</b></p>  <p>GICLEUR PRINCIPAL SOLEX GAPR<br/>CALIBRAGEM 137,5</p> <p>13.072/137,5</p>   | <p><b>52.101/140</b></p>  <p>GICLEUR PRINCIPAL SOLEX GAPR<br/>CALIBRAGEM 140</p> <p>13.072/140</p>   |
| <p><b>52.101/142,5</b></p>  <p>GICLEUR PRINCIPAL SOLEX GAPR<br/>CALIBRAGEM 142,5</p> <p>13.072/142,5</p>   | <p><b>52.101/145</b></p>  <p>GICLEUR PRINCIPAL SOLEX GAPR<br/>CALIBRAGEM 145</p> <p>13.072/145</p>         | <p><b>52.101/147,5</b></p>  <p>GICLEUR PRINCIPAL SOLEX GAPR<br/>CALIBRAGEM 147,5</p> <p>13.072/147,5</p>   | <p><b>52.101/150</b></p>  <p>GICLEUR PRINCIPAL SOLEX GAPR<br/>CALIBRAGEM 150</p> <p>13.072/150</p>   |
| <p><b>52.101/152,5</b></p>  <p>GICLEUR PRINCIPAL SOLEX GAPR<br/>CALIBRAGEM 152,5</p> <p>13.072/152,5</p>   | <p><b>52.101/155</b></p>  <p>GICLEUR PRINCIPAL SOLEX GAPR<br/>CALIBRAGEM 155</p> <p>13.072/155</p>         | <p><b>52.101/157,5</b></p>  <p>GICLEUR PRINCIPAL SOLEX GAPR<br/>CALIBRAGEM 157,5</p> <p>13.072/157,5</p>   | <p><b>52.101/160</b></p>  <p>GICLEUR PRINCIPAL SOLEX GAPR<br/>CALIBRAGEM 160</p> <p>13.072/160</p>   |
| <p><b>52.101/162,5</b></p>  <p>GICLEUR PRINCIPAL SOLEX GAPR<br/>CALIBRAGEM 162,5</p> <p>13.072/162,5</p> | <p><b>52.101/165</b></p>  <p>GICLEUR PRINCIPAL SOLEX GAPR<br/>CALIBRAGEM 165</p> <p>13.072/165</p>       | <p><b>52.101/167,5</b></p>  <p>GICLEUR PRINCIPAL SOLEX GAPR<br/>CALIBRAGEM 167,5</p> <p>13.072/167,5</p> | <p><b>52.101/170</b></p>  <p>GICLEUR PRINCIPAL SOLEX GAPR<br/>CALIBRAGEM 170</p> <p>13.072/170</p> |
| <p><b>52.101/172,5</b></p>  <p>GICLEUR PRINCIPAL SOLEX GAPR<br/>CALIBRAGEM 172,5</p> <p>13.072/172,5</p> | <p><b>52.101/175</b></p>  <p>GICLEUR PRINCIPAL SOLEX GAPR<br/>CALIBRAGEM 175</p> <p>13.072/175</p>       | <p><b>52.101/177,5</b></p>  <p>GICLEUR PRINCIPAL SOLEX GAPR<br/>CALIBRAGEM 177,5</p> <p>13.072/177,5</p> | <p><b>52.101/180</b></p>  <p>GICLEUR PRINCIPAL SOLEX GAPR<br/>CALIBRAGEM 180</p> <p>13.072/180</p> |
| <p><b>52.101/185</b></p>  <p>GICLEUR PRINCIPAL SOLEX GAPR<br/>CALIBRAGEM 185</p> <p>13.072/185</p>       | <p><b>52.101/187,5</b></p>  <p>GICLEUR PRINCIPAL SOLEX GAPR<br/>CALIBRAGEM 187,5</p> <p>13.072/187,5</p> | <p><b>52.101/190</b></p>  <p>GICLEUR PRINCIPAL SOLEX GAPR<br/>CALIBRAGEM 190</p> <p>13.072/190</p>       | <p><b>52.101/195</b></p>  <p>GICLEUR PRINCIPAL SOLEX GAPR<br/>CALIBRAGEM 195</p> <p>13.072/195</p> |

**265 GICLEUR PRINCIPAL SOLEX ( GAPR ) \*EMBALAGEM 10UN PREÇO UN\***

|   |   |  |   |
|---|---|--|---|
| <p><b>52.101/200</b></p>  <p>GICLEUR PRINCIPAL SOLEX GAPR<br/>CALIBRAGEM 200</p> <p>13.072/200</p> | <p><b>52.101/205</b></p>  <p>GICLEUR PRINCIPAL SOLEX GAPR<br/>CALIBRAGEM 205</p> <p>13.072/205</p> | <p><b>52.101/210</b></p>  <p>GICLEUR PRINCIPAL SOLEX GAPR<br/>CALIBRAGEM 210</p> <p>13.072/210</p> | <p><b>52.101/215</b></p>  <p>GICLEUR PRINCIPAL SOLEX GAPR<br/>CALIBRAGEM 215</p> <p>13.072/215</p> |
| <p><b>52.101/220</b></p>  <p>GICLEUR PRINCIPAL SOLEX GAPR<br/>CALIBRAGEM 220</p> <p>13.072/220</p> | <p><b>52.101/225</b></p>  <p>GICLEUR PRINCIPAL SOLEX GAPR<br/>CALIBRAGEM 225</p> <p>13.072/225</p> | <p><b>52.101/230</b></p>  <p>GICLEUR PRINCIPAL SOLEX GAPR<br/>CALIBRAGEM 230</p> <p>13.072/230</p> | <p><b>52.101/235</b></p>  <p>GICLEUR PRINCIPAL SOLEX GAPR<br/>CALIBRAGEM 235</p> <p>13.072/235</p> |
| <p><b>52.101/240</b></p>  <p>GICLEUR PRINCIPAL SOLEX GAPR<br/>CALIBRAGEM 240</p> <p>13.072/240</p> |   |  |   |

**270 GICLEUR PRINCIPAL SOLEX 35 ALFA 1 (GPMS) \*EMBALAGEM 10UN PREÇO UN\***

|  |  |   |  |
|--|--|---|--|
| <p><b>52.451/110</b></p>  <p>GICLEUR PRINCIPAL SOLEX 35 ALFA-1 ...<br/>GPMS CALIBRAGEM 110</p> <p>160.072/110</p> | <p><b>52.451/115</b></p>  <p>GICLEUR PRINCIPAL SOLEX 35 ALFA-1 ...<br/>GPMS CALIBRAGEM 115</p> <p>160.072/115</p>       | <p><b>52.451/120</b></p>  <p>GICLEUR PRINCIPAL SOLEX 35 ALFA-1 ...<br/>GPMS CALIBRAGEM 120</p> <p>160.072/120</p> | <p><b>52.451/125</b></p>  <p>GICLEUR PRINCIPAL SOLEX 35 ALFA-1 ...<br/>GPMS CALIBRAGEM 125</p> <p>160.072/125</p>       |
| <p><b>52.451/130</b></p>  <p>GICLEUR PRINCIPAL SOLEX 35 ALFA-1 ...<br/>GPMS CALIBRAGEM 130</p> <p>160.072/130</p> | <p><b>52.451/132,5</b></p>  <p>GICLEUR PRINCIPAL SOLEX 35 ALFA-1 ...<br/>GPMS CALIBRAGEM 132,5</p> <p>160.072/132,5</p> | <p><b>52.451/135</b></p>  <p>GICLEUR PRINCIPAL SOLEX 35 ALFA-1 ...<br/>GPMS CALIBRAGEM 135</p> <p>160.072/135</p> | <p><b>52.451/137,5</b></p>  <p>GICLEUR PRINCIPAL SOLEX 35 ALFA-1 ...<br/>GPMS CALIBRAGEM 137,5</p> <p>160.072/137,5</p> |
| <p><b>52.451/140</b></p>  <p>GICLEUR PRINCIPAL SOLEX 35 ALFA-1 ...<br/>GPMS CALIBRAGEM 140</p> <p>160.072/140</p> | <p><b>52.451/142,5</b></p>  <p>GICLEUR PRINCIPAL SOLEX 35 ALFA-1 ...<br/>GPMS CALIBRAGEM 142,5</p> <p>160.072/142,5</p> | <p><b>52.451/145</b></p>  <p>GICLEUR PRINCIPAL SOLEX 35 ALFA-1 ...<br/>GPMS CALIBRAGEM 145</p> <p>160.072/145</p> | <p><b>52.451/147,5</b></p>  <p>GICLEUR PRINCIPAL SOLEX 35 ALFA-1 ...<br/>GPMS CALIBRAGEM 147,5</p> <p>160.072/147,5</p> |

**270 GICLEUR PRINC SOLEX 35 ALFA 1(GPMS) \*EMBALAGEM 10UN PREÇO UN\***

|  |  |  |  |
|--|--|--|--|
| <p><b>52.451/150</b></p> <p>GICLEUR PRINCIPAL SOLEX 35 ALFA-1 ...<br/>GPMS CALIBRAGEM 150</p> <p>160.072/150</p> | <p><b>52.451/152,5</b></p> <p>GICLEUR PRINCIPAL SOLEX 35 ALFA-1 ...<br/>GPMS CALIBRAGEM 152,5</p> <p>160.072/152,5</p> | <p><b>52.451/155</b></p> <p>GICLEUR PRINCIPAL SOLEX 35 ALFA-1 ...<br/>GPMS CALIBRAGEM 155</p> <p>160.072/155</p> | <p><b>52.451/157,5</b></p> <p>GICLEUR PRINCIPAL SOLEX 35 ALFA-1 ...<br/>GPMS CALIBRAGEM 157,5</p> <p>160.072/157,5</p> |
| <p><b>52.451/160</b></p> <p>GICLEUR PRINCIPAL SOLEX 35 ALFA-1 ...<br/>GPMS CALIBRAGEM 160</p> <p>160.072/160</p> | <p><b>52.451/162,5</b></p> <p>GICLEUR PRINCIPAL SOLEX 35 ALFA-1 ...<br/>GPMS CALIBRAGEM 162,5</p> <p>160.072/162,5</p> | <p><b>52.451/165</b></p> <p>GICLEUR PRINCIPAL SOLEX 35 ALFA-1 ...<br/>GPMS CALIBRAGEM 165</p> <p>160.072/165</p> | <p><b>52.451/167,5</b></p> <p>GICLEUR PRINCIPAL SOLEX 35 ALFA-1 ...<br/>GPMS CALIBRAGEM 167,5</p> <p>160.072/167,5</p> |
| <p><b>52.451/170</b></p> <p>GICLEUR PRINCIPAL SOLEX 35 ALFA-1 ...<br/>GPMS CALIBRAGEM 170</p> <p>160.072/170</p> | <p><b>52.451/172,5</b></p> <p>GICLEUR PRINCIPAL SOLEX 35 ALFA-1 ...<br/>GPMS CALIBRAGEM 172,5</p> <p>160.072/172,5</p> |  |  |

**275 GICLEUR PRINC 190/495 TLDZ (GPTLDZ) \*EMBALAGEM 10UN PREÇO UN\***

|  |  |  |  |
|--|--|--|--|
| <p><b>52.201/090</b></p> <p>GICLEUR PRINCIPAL WEBER 190/495 TLDZ<br/>GPTLDZ CALIBRAGEM 90</p> <p>319.409.02</p>  | <p><b>52.201/092</b></p> <p>GICLEUR PRINCIPAL WEBER 190/495 TLDZ<br/>GPTLDZ CALIBRAGEM 92</p> <p>319.409.22</p>  | <p><b>52.201/095</b></p> <p>GICLEUR PRINCIPAL WEBER 190/495 TLDZ<br/>GPTLDZ CALIBRAGEM 95</p> <p>319.409.52</p>  | <p><b>52.201/097</b></p> <p>GICLEUR PRINCIPAL WEBER 190/495 TLDZ<br/>GPTLDZ CALIBRAGEM 97</p> <p>319.409.72</p>  |
| <p><b>52.201/100</b></p> <p>GICLEUR PRINCIPAL WEBER 190/495 TLDZ<br/>GPTLDZ CALIBRAGEM 100</p> <p>319.410.02</p> | <p><b>52.201/102</b></p> <p>GICLEUR PRINCIPAL WEBER 190/495 TLDZ<br/>GPTLDZ CALIBRAGEM 102</p> <p>319.410.22</p> | <p><b>52.201/105</b></p> <p>GICLEUR PRINCIPAL WEBER 190/495 TLDZ<br/>GPTLDZ CALIBRAGEM 105</p> <p>319.410.52</p> | <p><b>52.201/107</b></p> <p>GICLEUR PRINCIPAL WEBER 190/495 TLDZ<br/>GPTLDZ CALIBRAGEM 107</p> <p>319.410.72</p> |
| <p><b>52.201/110</b></p> <p>GICLEUR PRINCIPAL WEBER 190/495 TLDZ<br/>GPTLDZ CALIBRAGEM 110</p> <p>319.411.02</p> | <p><b>52.201/112</b></p> <p>GICLEUR PRINCIPAL WEBER 190/495 TLDZ<br/>GPTLDZ CALIBRAGEM 112</p> <p>319.411.22</p> | <p><b>52.201/115</b></p> <p>GICLEUR PRINCIPAL WEBER 190/495 TLDZ<br/>GPTLDZ CALIBRAGEM 115</p> <p>319.411.52</p> | <p><b>52.201/117</b></p> <p>GICLEUR PRINCIPAL WEBER 190/495 TLDZ<br/>GPTLDZ CALIBRAGEM 117</p> <p>319.411.72</p> |



**275 GICLEUR PRINC 190/495 TLDZ (GPTLDZ) \*EMBALAGEM 10UN PREÇO UN\***

|  |  |  |  |
|--|--|--|--|
| <p><b>52.201/120</b></p> <p>GICLEUR PRINCIPAL WEBER 190/495 TLDZ<br/>GPTLDZ CALIBRAGEM 120</p> <p>319.412.02</p> | <p><b>52.201/122</b></p> <p>GICLEUR PRINCIPAL WEBER 190/495 TLDZ<br/>GPTLDZ CALIBRAGEM 122</p> <p>319.412.22</p> | <p><b>52.201/125</b></p> <p>GICLEUR PRINCIPAL WEBER 190/495 TLDZ<br/>GPTLDZ CALIBRAGEM 125</p> <p>319.412.52</p> | <p><b>52.201/127</b></p> <p>GICLEUR PRINCIPAL WEBER 190/495 TLDZ<br/>GPTLDZ CALIBRAGEM 127</p> <p>319.412.72</p> |
| <p><b>52.201/130</b></p> <p>GICLEUR PRINCIPAL WEBER 190/495 TLDZ<br/>GPTLDZ CALIBRAGEM 130</p> <p>319.413.02</p> | <p><b>52.201/132</b></p> <p>GICLEUR PRINCIPAL WEBER 190/495 TLDZ<br/>GPTLDZ CALIBRAGEM 132</p> <p>319.413.22</p> | <p><b>52.201/135</b></p> <p>GICLEUR PRINCIPAL WEBER 190/495 TLDZ<br/>GPTLDZ CALIBRAGEM 135</p> <p>319.413.52</p> | <p><b>52.201/137</b></p> <p>GICLEUR PRINCIPAL WEBER 190/495 TLDZ<br/>GPTLDZ CALIBRAGEM 137</p> <p>319.413.72</p> |
| <p><b>52.201/140</b></p> <p>GICLEUR PRINCIPAL WEBER 190/495 TLDZ<br/>GPTLDZ CALIBRAGEM 140</p> <p>319.414.02</p> | <p><b>52.201/142</b></p> <p>GICLEUR PRINCIPAL WEBER 190/495 TLDZ<br/>GPTLDZ CALIBRAGEM 142</p> <p>319.414.22</p> | <p><b>52.201/145</b></p> <p>GICLEUR PRINCIPAL WEBER 190/495 TLDZ<br/>GPTLDZ CALIBRAGEM 145</p> <p>319.414.52</p> | <p><b>52.201/147</b></p> <p>GICLEUR PRINCIPAL WEBER 190/495 TLDZ<br/>GPTLDZ CALIBRAGEM 147</p> <p>319.414.72</p> |
| <p><b>52.201/150</b></p> <p>GICLEUR PRINCIPAL WEBER 190/495 TLDZ<br/>GPTLDZ CALIBRAGEM 150</p> <p>319.415.02</p> | <p><b>52.201/152</b></p> <p>GICLEUR PRINCIPAL WEBER 190/495 TLDZ<br/>GPTLDZ CALIBRAGEM 152</p> <p>319.415.22</p> | <p><b>52.201/155</b></p> <p>GICLEUR PRINCIPAL WEBER 190/495 TLDZ<br/>GPTLDZ CALIBRAGEM 155</p> <p>319.415.52</p> | <p><b>52.201/157</b></p> <p>GICLEUR PRINCIPAL WEBER 190/495 TLDZ<br/>GPTLDZ CALIBRAGEM 157</p> <p>319.415.72</p> |
| <p><b>52.201/160</b></p> <p>GICLEUR PRINCIPAL WEBER 190/495 TLDZ<br/>GPTLDZ CALIBRAGEM 160</p> <p>319.416.02</p> | <p><b>52.201/162</b></p> <p>GICLEUR PRINCIPAL WEBER 190/495 TLDZ<br/>GPTLDZ CALIBRAGEM 162</p> <p>319.416.22</p> | <p><b>52.201/165</b></p> <p>GICLEUR PRINCIPAL WEBER 190/495 TLDZ<br/>GPTLDZ CALIBRAGEM 165</p> <p>319.416.52</p> | <p><b>52.201/167</b></p> <p>GICLEUR PRINCIPAL WEBER 190/495 TLDZ<br/>GPTLDZ CALIBRAGEM 167</p> <p>319.416.72</p> |
| <p><b>52.201/170</b></p> <p>GICLEUR PRINCIPAL WEBER 190/495 TLDZ<br/>GPTLDZ CALIBRAGEM 170</p> <p>319.417.02</p> | <p><b>52.201/172</b></p> <p>GICLEUR PRINCIPAL WEBER 190/495 TLDZ<br/>GPTLDZ CALIBRAGEM 172</p> <p>319.417.22</p> | <p><b>52.201/175</b></p> <p>GICLEUR PRINCIPAL WEBER 190/495 TLDZ<br/>GPTLDZ CALIBRAGEM 175</p> <p>319.417.52</p> | <p><b>52.201/177</b></p> <p>GICLEUR PRINCIPAL WEBER 190/495 TLDZ<br/>GPTLDZ CALIBRAGEM 177</p> <p>319.417.72</p> |

**275 GICLEUR PRINC 190/495 TLDZ (GPTLDZ) \*EMBALAGEM 10UN PREÇO UN\***

|  |  |  |  |
|--|--|--|--|
| <p><b>52.201/180</b></p> <p>GICLEUR PRINCIPAL WEBER 190/495 TLDZ<br/>GPTLDZ CALIBRAGEM 180</p> <p>319.418.02</p> | <p><b>52.201/182</b></p> <p>GICLEUR PRINCIPAL WEBER 190/495 TLDZ<br/>GPTLDZ CALIBRAGEM 182</p> <p>319.418.22</p> | <p><b>52.201/185</b></p> <p>GICLEUR PRINCIPAL WEBER 190/495 TLDZ<br/>GPTLDZ CALIBRAGEM 185</p> <p>319.418.52</p> | <p><b>52.201/187</b></p> <p>GICLEUR PRINCIPAL WEBER 190/495 TLDZ<br/>GPTLDZ CALIBRAGEM 187</p> <p>319.418.72</p> |
| <p><b>52.201/190</b></p> <p>GICLEUR PRINCIPAL WEBER 190/495 TLDZ<br/>GPTLDZ CALIBRAGEM 190</p> <p>319.419.02</p> | <p><b>52.201/192</b></p> <p>GICLEUR PRINCIPAL WEBER 190/495 TLDZ<br/>GPTLDZ CALIBRAGEM 192</p> <p>319.419.22</p> | <p><b>52.201/195</b></p> <p>GICLEUR PRINCIPAL WEBER 190/495 TLDZ<br/>GPTLDZ CALIBRAGEM 195</p> <p>319.419.52</p> | <p><b>52.201/197</b></p> <p>GICLEUR PRINCIPAL WEBER 190/495 TLDZ<br/>GPTLDZ CALIBRAGEM 197</p> <p>319.419.72</p> |
| <p><b>52.201/200</b></p> <p>GICLEUR PRINCIPAL WEBER 190/495 TLDZ<br/>GPTLDZ CALIBRAGEM 200</p> <p>319.420.02</p> | <p><b>52.201/205</b></p> <p>GICLEUR PRINCIPAL WEBER 190/495 TLDZ<br/>GPTLDZ CALIBRAGEM 205</p> <p>319.420.52</p> | <p><b>52.201/210</b></p> <p>GICLEUR PRINCIPAL WEBER 190/495 TLDZ<br/>GPTLDZ CALIBRAGEM 210</p> <p>319.421.02</p> | <p><b>52.201/215</b></p> <p>GICLEUR PRINCIPAL WEBER 190/495 TLDZ<br/>GPTLDZ CALIBRAGEM 215</p> <p>319.421.52</p> |
| <p><b>52.201/220</b></p> <p>GICLEUR PRINCIPAL WEBER 190/495 TLDZ<br/>GPTLDZ CALIBRAGEM 220</p> <p>319.422.02</p> |  |  |  |

**280 GICLEUR MARCHA LENTA (GMLDFV) \*EMBALAGEM 10UN PREÇO UN\***

|   |   |   |   |
|---|---|---|---|
| <p><b>52.581/050</b></p> <p>GICLEUR MARCHA LENTA WEBER 228<br/>GMLDFV CALIBRAGEM 50</p> <p>301.701.50</p> | <p><b>52.581/055</b></p> <p>GICLEUR MARCHA LENTA WEBER 228<br/>GMLDFV CALIBRAGEM 55</p> <p>301.701.55</p> | <p><b>52.581/060</b></p> <p>GICLEUR MARCHA LENTA WEBER 228<br/>GMLDFV CALIBRAGEM 60</p> <p>301.701.60</p> | <p><b>52.581/065</b></p> <p>GICLEUR MARCHA LENTA WEBER 228<br/>GMLDFV CALIBRAGEM 65</p> <p>301.701.65</p> |
| <p><b>52.581/070</b></p> <p>GICLEUR MARCHA LENTA WEBER 228<br/>GMLDFV CALIBRAGEM 70</p> <p>301.701.70</p> | <p><b>52.581/075</b></p> <p>GICLEUR MARCHA LENTA WEBER 228<br/>GMLDFV CALIBRAGEM 75</p> <p>301.701.75</p> | <p><b>52.581/080</b></p> <p>GICLEUR MARCHA LENTA WEBER 228<br/>GMLDFV CALIBRAGEM 80</p> <p>301.701.80</p> |   |

**285 GICLEUR M LENTA WEBER(GMLTLDZ) FINO \*EMBALAGEM 10UN PREÇO UN\***

**285 GICLEUR M LENTA WEBER(GMLTLDZ) FINO \*EMBALAGEM 10UN PREÇO UN\***

|  |  |   |  |
|--|--|---|--|
| <p><b>52.652/047</b></p>  <p>GICLEUR MARCHA LENTA WEBER 495<br/>TLDZ/TLDF GMLTLDZ FINO CALIBRAGEM 47</p> <p>340.404.72/47</p> | <p><b>52.652/050</b></p>  <p>GICLEUR MARCHA LENTA WEBER 495<br/>TLDZ/TLDF GMLTLDZ FINO CALIBRAGEM 50</p> <p>340.405.02/50</p> | <p><b>52.652/052</b></p>  <p>GICLEUR MARCHA LENTA WEBER 495<br/>TLDZ/TLDF GMLTLDZ FINO CALIBRAGEM 52</p> <p>341.405.22/52</p> | <p><b>52.652/055</b></p>  <p>GICLEUR MARCHA LENTA WEBER 495<br/>TLDZ/TLDF GMLTLDZ FINO CALIBRAGEM 55</p> <p>341.405.52/55</p> |
| <p><b>52.652/057</b></p>  <p>GICLEUR MARCHA LENTA WEBER 495<br/>TLDZ/TLDF GMLTLDZ FINO CALIBRAGEM 57</p> <p>341.405.72/57</p> | <p><b>52.652/060</b></p>  <p>GICLEUR MARCHA LENTA WEBER 495<br/>TLDZ/TLDF GMLTLDZ FINO CALIBRAGEM 60</p> <p>340.406.02/60</p> | <p><b>52.652/062</b></p>  <p>GICLEUR MARCHA LENTA WEBER 495<br/>TLDZ/TLDF GMLTLDZ FINO CALIBRAGEM 62</p> <p>341.706.22/62</p> | <p><b>52.652/085</b></p>  <p>GICLEUR MARCHA LENTA WEBER 495<br/>TLDZ/TLDF GMLTLDZ FINO CALIBRAGEM 85</p> <p>341.408.52/85</p> |
| <p><b>52.652/090</b></p>  <p>GICLEUR MARCHA LENTA WEBER 495<br/>TLDZ/TLDF GMLTLDZ FINO CALIBRAGEM 90</p> <p>340.409.02/90</p> |  |   |  |

**290 GICLEUR M LENTA WEBER CHT (GPML) \*EMBALAGEM 10UN PREÇO UN\***

|   |   |  |   |
|---|---|--|---|
| <p><b>52.631/040</b></p>  <p>GICLEUR MARCHA LENTA WEBER 460 CHT<br/>GPML CALIBRAGEM 40</p> <p>467.204.02</p> | <p><b>52.631/042</b></p>  <p>GICLEUR MARCHA LENTA WEBER 460 CHT<br/>GPML CALIBRAGEM 42</p> <p>467.204.22</p> | <p><b>52.631/045</b></p>  <p>GICLEUR MARCHA LENTA WEBER 460 CHT<br/>GPML CALIBRAGEM 45</p> <p>467.204.52</p> | <p><b>52.631/047</b></p>  <p>GICLEUR MARCHA LENTA WEBER 460 CHT<br/>GPML CALIBRAGEM 47</p> <p>467.204.72</p> |
| <p><b>52.631/050</b></p>  <p>GICLEUR MARCHA LENTA WEBER 460 CHT<br/>GPML CALIBRAGEM 50</p> <p>467.205.02</p> | <p><b>52.631/052</b></p>  <p>GICLEUR MARCHA LENTA WEBER 460 CHT<br/>GPML CALIBRAGEM 52</p> <p>467.205.22</p> | <p><b>52.631/055</b></p>  <p>GICLEUR MARCHA LENTA WEBER 460 CHT<br/>GPML CALIBRAGEM 55</p> <p>467.205.52</p> | <p><b>52.631/057</b></p>  <p>GICLEUR MARCHA LENTA WEBER 460 CHT<br/>GPML CALIBRAGEM 57</p> <p>467.205.72</p> |
| <p><b>52.631/060</b></p>  <p>GICLEUR MARCHA LENTA WEBER 460 CHT<br/>GPML CALIBRAGEM 60</p> <p>467.206.02</p> | <p><b>52.631/062</b></p>  <p>GICLEUR MARCHA LENTA WEBER 460 CHT<br/>GPML CALIBRAGEM 62</p> <p>467.206.22</p> | <p><b>52.631/065</b></p>  <p>GICLEUR MARCHA LENTA WEBER 460 CHT<br/>GPML CALIBRAGEM 65</p> <p>467.206.52</p> | <p><b>52.631/067</b></p>  <p>GICLEUR MARCHA LENTA WEBER 460 CHT<br/>GPML CALIBRAGEM 67</p> <p>467.206.72</p> |

**290 GICLEUR M LENTA WEBER CHT (GPML) \*EMBALAGEM 10UN PREÇO UN\***

|  |   |  |   |
|--|---|--|---|
| <p><b>52.631/070</b></p>  <p>GICLEUR MARCHA LENTA WEBER 460 CHT<br/>GPML CALIBRAGEM 70</p> <p>467.207.02</p>  | <p><b>52.631/072</b></p>  <p>GICLEUR MARCHA LENTA WEBER 460 CHT<br/>GPML CALIBRAGEM 72</p> <p>467.207.22</p> | <p><b>52.631/075</b></p>  <p>GICLEUR MARCHA LENTA WEBER 460 CHT<br/>GPML CALIBRAGEM 75</p> <p>467.207.52</p> | <p><b>52.631/077</b></p>  <p>GICLEUR MARCHA LENTA WEBER 460 CHT<br/>GPML CALIBRAGEM 77</p> <p>467.207.72</p> |
| <p><b>52.631/080</b></p>  <p>GICLEUR MARCHA LENTA WEBER 460 CHT<br/>GPML CALIBRAGEM 80</p> <p>467.208.02</p>  | <p><b>52.631/082</b></p>  <p>GICLEUR MARCHA LENTA WEBER 460 CHT<br/>GPML CALIBRAGEM 82</p> <p>467.208.22</p> | <p><b>52.631/085</b></p>  <p>GICLEUR MARCHA LENTA WEBER 460 CHT<br/>GPML CALIBRAGEM 85</p> <p>467.208.52</p> | <p><b>52.631/087</b></p>  <p>GICLEUR MARCHA LENTA WEBER 460 CHT<br/>GPML CALIBRAGEM 87</p> <p>467.208.72</p> |
| <p><b>52.631/090</b></p>  <p>GICLEUR MARCHA LENTA WEBER 460 CHT<br/>GPML CALIBRAGEM 90</p> <p>467.209.02</p> |   |  |   |

**295 GICLEUR M L WEBER MINI PROG (GGML) \*EMBALAGEM 10UN PREÇO UN\***

|   |   |  |   |
|---|---|--|---|
| <p><b>52.591/040</b></p>  <p>GICLEUR MARCHA LENTA WEBER 190/ 450<br/>MINI MODERNO GGML CALIBRAGEM 40</p> <p>468.604.02</p> | <p><b>52.591/042</b></p>  <p>GICLEUR MARCHA LENTA WEBER 190/ 450<br/>MINI MODERNO GGML CALIBRAGEM 42</p> <p>468.604.22</p> | <p><b>52.591/045</b></p>  <p>GICLEUR MARCHA LENTA WEBER 190/ 450<br/>MINI MODERNO GGML CALIBRAGEM 45</p> <p>468.604.52</p> | <p><b>52.591/047</b></p>  <p>GICLEUR MARCHA LENTA WEBER 190/ 450<br/>MINI MODERNO GGML CALIBRAGEM 47</p> <p>468.604.72</p> |
| <p><b>52.591/050</b></p>  <p>GICLEUR MARCHA LENTA WEBER 190/ 450<br/>MINI MODERNO GGML CALIBRAGEM 50</p> <p>468.605.02</p> | <p><b>52.591/052</b></p>  <p>GICLEUR MARCHA LENTA WEBER 190/ 450<br/>MINI MODERNO GGML CALIBRAGEM 52</p> <p>468.605.22</p> | <p><b>52.591/055</b></p>  <p>GICLEUR MARCHA LENTA WEBER 190/ 450<br/>MINI MODERNO GGML CALIBRAGEM 55</p> <p>468.605.52</p> | <p><b>52.591/057</b></p>  <p>GICLEUR MARCHA LENTA WEBER 190/ 450<br/>MINI MODERNO GGML CALIBRAGEM 57</p> <p>468.605.72</p> |
| <p><b>52.591/060</b></p>  <p>GICLEUR MARCHA LENTA WEBER 190/ 450<br/>MINI MODERNO GGML CALIBRAGEM 60</p> <p>468.606.02</p> | <p><b>52.591/062</b></p>  <p>GICLEUR MARCHA LENTA WEBER 190/ 450<br/>MINI MODERNO GGML CALIBRAGEM 62</p> <p>468.606.22</p> | <p><b>52.591/065</b></p>  <p>GICLEUR MARCHA LENTA WEBER 190/ 450<br/>MINI MODERNO GGML CALIBRAGEM 65</p> <p>468.606.52</p> | <p><b>52.591/067</b></p>  <p>GICLEUR MARCHA LENTA WEBER 190/ 450<br/>MINI MODERNO GGML CALIBRAGEM 67</p> <p>468.606.72</p> |









**295 GICLEUR M L WEBER MINI PROG (GGML) \*EMBALAGEM 10UN PREÇO UN\***

|   |   |   |   |
|---|---|---|---|
| <p><b>52.591/070</b></p> <p>GICLEUR MARCHA LENTA WEBER 190/ 450 MINI MODERNO GGML CALIBRAGEM 70</p> <p>468.607.02</p> | <p><b>52.591/072</b></p> <p>GICLEUR MARCHA LENTA WEBER 190/ 450 MINI MODERNO GGML CALIBRAGEM 72</p> <p>468.607.22</p> | <p><b>52.591/075</b></p> <p>GICLEUR MARCHA LENTA WEBER 190/ 450 MINI MODERNO GGML CALIBRAGEM 75</p> <p>468.607.52</p> | <p><b>52.591/077</b></p> <p>GICLEUR MARCHA LENTA WEBER 190/ 450 MINI MODERNO GGML CALIBRAGEM 77</p> <p>468.607.72</p> |
| <p><b>52.591/080</b></p> <p>GICLEUR MARCHA LENTA WEBER 190/ 450 MINI MODERNO GGML CALIBRAGEM 80</p> <p>468.608.02</p> | <p><b>52.591/082</b></p> <p>GICLEUR MARCHA LENTA WEBER 190/ 450 MINI MODERNO GGML CALIBRAGEM 82</p> <p>468.608.22</p> | <p><b>52.591/085</b></p> <p>GICLEUR MARCHA LENTA WEBER 190/ 450 MINI MODERNO GGML CALIBRAGEM 85</p> <p>468.608.52</p> | <p><b>52.591/090</b></p> <p>GICLEUR MARCHA LENTA WEBER 190/ 450 MINI MODERNO GGML CALIBRAGEM 90</p> <p>468.609.02</p> |

**300 GICLEUR DE M LENTA C/ TUBO 2E/3E \*EMBALAGEM 10UN PREÇO UN\***

|  |  |   |   |
|--|--|---|---|
| <p><b>52.653</b></p> <p>GICLEUR MARCHA LENTA C/TUBO SOLEX 2E7/3E<br/>QUANTUM/ GOL GLS/ PARATI GLS GASOLINA - 175.218/45x120</p>  | <p><b>52.654</b></p> <p>GICLEUR MARCHA LENTA C/TUBO SOLEX 2E7/3E<br/>ESCORT/ VERONA/ LOGUS 2.0 GASOLINA - 176.215/50x125</p>     | <p><b>52.655</b></p> <p>GICLEUR MARCHA LENTA C/TUBO SOLEX 2E7/3E<br/>PAMPA 1.8 GASOLINA - 175.219/45x135</p>                    | <p><b>52.656</b></p> <p>GICLEUR MARCHA LENTA C/TUBO SOLEX 2E7/3E<br/>POINTER/ ESCORT/ VERONA/ LOGUS GASOLINA - 175.217/47x135</p> |
| <p><b>52.657</b></p> <p>GICLEUR MARCHA LENTA C/TUBO SOLEX 2E7/3E<br/>GOL/ VOYAGE/ QUANTUM GASOLINA - 175.202/80x140</p>          | <p><b>52.658</b></p> <p>GICLEUR MARCHA LENTA C/TUBO SOLEX 2E7/3E<br/>QUANTUM/ VERSALES/ ROYALE GASOLINA - 176.210/57x145</p>     | <p><b>52.659</b></p> <p>GICLEUR MARCHA LENTA C/TUBO SOLEX 2E7/3E<br/>SANTANA 2.0/ QUANTUM 2.0 GASOLINA - 175.210/47x150</p>     | <p><b>52.660</b></p> <p>GICLEUR MARCHA LENTA C/TUBO SOLEX 2E7/3E<br/>VERSALES/ ROYALE 1.8/ GOL GTS GASOLINA - 175.212/47x160</p>  |
| <p><b>52.661</b></p> <p>GICLEUR MARCHA LENTA C/TUBO SOLEX 2E7/3E<br/>ESCORT/ VERONA/ APOLLO 1.8 GASOLINA - 176.213/52x160</p>    | <p><b>52.662</b></p> <p>GICLEUR MARCHA LENTA C/TUBO SOLEX 2E7/3E<br/>CHEVET/ MARAJÓ/ CHEVY 500 1.6 GASOLINA - 174.204/55x160</p> | <p><b>52.663</b></p> <p>GICLEUR MARCHA LENTA C/TUBO SOLEX 2E7/3E<br/>OPALA/ CARAVAN/ VERANEIO 6CC GASOLINA - 176.210/57x160</p> | <p><b>52.664</b></p> <p>GICLEUR MARCHA LENTA C/TUBO SOLEX 2E7/3E<br/>CHEVETTE 1.6 GASOLINA - 174.205/65x160</p>                   |
| <p><b>52.665</b></p> <p>GICLEUR MARCHA LENTA C/TUBO SOLEX 2E7/3E<br/>ESCORT/ VERONA/ APOLLO/ MONZA GASOLINA - 176.201/52x145</p> | <p><b>52.667</b></p> <p>GICLEUR MARCHA LENTA C/TUBO SOLEX 2E7/3E<br/>ESCORT/ LOGUS/ VERONA/ POINTER ÁLCOOL - 175.220/57x125</p>  | <p><b>52.668</b></p> <p>GICLEUR MARCHA LENTA C/TUBO SOLEX 2E7/3E<br/>APOLO/ ESCORT/ VERONA ÁLCOOL - 175.216/67x135</p>          | <p><b>52.669</b></p> <p>GICLEUR MARCHA LENTA C/TUBO SOLEX 2E7/3E<br/>VERSALLES 2.0 ÁLCOOL - 176.216/80x140</p>                    |

**300 GICLEUR DE M LENTA C/ TUBO 2E/3E \*EMBALAGEM 10UN PREÇO UN\***

|   |  |  |  |
|---|--|--|--|
| <p><b>52.670</b></p>  <p>GICLEUR MARCHA LENTA C/TUBO SOLEX 2E7/3E<br/>PAMPA 1.8 ÁLCOOL - 175.215/62x145</p>                        | <p><b>52.671</b></p>  <p>GICLEUR MARCHA LENTA C/TUBO SOLEX 2E7/3E<br/>ESCORT GHIA/ VERONA 1.8 ÁLCOOL - 175.205/72,5x135</p>           | <p><b>52.672</b></p>  <p>GICLEUR MARCHA LENTA C/TUBO SOLEX 2E7/3E<br/>GOL GTS/ SANTANA/ PASSAT GTS GASOLINA - 175.069/50X150</p> | <p><b>52.673</b></p>  <p>GICLEUR MARCHA LENTA C/TUBO SOLEX 2E7/3E<br/>PAMPA/ DEL REY ÁLCOOL - 174.201/67,5x145</p>                            |
| <p><b>52.674</b></p>  <p>GICLEUR MARCHA LENTA C/TUBO SOLEX 2E7/3E<br/>PAMPA/ DEL REY 1.8 GASOLINA - 176.206/52,5x150</p>           | <p><b>52.675</b></p>  <p>GICLEUR MARCHA LENTA C/TUBO SOLEX 2E7/3E<br/>MONZA/KADET 1.8/2.0 4 FUROS GASOLINA - 174.200/52,5x155</p>     | <p><b>52.676</b></p>  <p>GICLEUR MARCHA LENTA C/TUBO SOLEX 2E7/3E<br/>MONZA 2.0 GASOLINA - 174.203/52,5x145</p>                  | <p><b>52.677</b></p>  <p>GICLEUR MARCHA LENTA C/TUBO SOLEX 2E7/3E<br/>MONZA/ KADET 1.8 ÁLCOOL - 175.201/50x140</p>                            |
| <p><b>52.678</b></p>  <p>GICLEUR MARCHA LENTA C/TUBO SOLEX 2E7/3E<br/>KADET/ MONZA 1.8 4 FUROS ÁLCOOL - 176.201/57,5x140</p>       | <p><b>52.679</b></p>  <p>GICLEUR MARCHA LENTA C/TUBO SOLEX 2E7/3E<br/>OPALA 4CC ÁLCOOL - 176.204/57,5x155</p>                         | <p><b>52.680</b></p>  <p>GICLEUR MARCHA LENTA C/TUBO SOLEX 2E7/3E<br/>OPALA 6CC ÁLCOOL - 176.205/60x160</p>                      | <p><b>52.681</b></p>  <p>GICLEUR MARCHA LENTA C/TUBO SOLEX 2E7/3E<br/>OPALA 6CC GASOLINA - 176.210/62,5x160</p>                               |
| <p><b>52.683</b></p>  <p>GICLEUR MARCHA LENTA C/TUBO SOLEX 2E7/3E<br/>SANTANA 2.0/ VERSALES/ ROYALE ÁLCOOL - 176.208/80x160</p>  | <p><b>52.686</b></p>  <p>GICLEUR MARCHA LENTA C/TUBO SOLEX 2E7/3E<br/>PASSAT GTS/ QUANTUM 1.8 ÁLCOOL - 175.202/60x140</p>           | <p><b>52.687</b></p>  <p>GICLEUR MARCHA LENTA C/TUBO SOLEX 2E7/3E<br/>GOL GT/ PASSAT 1.8/ QUANTUM ÁLCOOL - 145.209/60x145</p>  | <p><b>52.688</b></p>  <p>GICLEUR MARCHA LENTA C/TUBO SOLEX 2E7/3E<br/>PASSAT GTS/SANTANA/QUANTUM 1.8 APÓS 03/85 ÁLCOOL - 175.200/60x155</p> |
| <p><b>52.689</b></p>  <p>GICLEUR MARCHA LENTA C/TUBO SOLEX 2E7/3E<br/>SANTANA/QUANTUM 2.0 APÓS 05/88 ÁLCOOL - 175.204/65x135</p> | <p><b>52.690</b></p>  <p>GICLEUR MARCHA LENTA C/TUBO SOLEX 2E7/3E<br/>GOL GTS/ PASSAT GLS/ VOYAGE GLS GASOLINA - 175.209/50x155</p> | <p><b>52.691</b></p>  <p>GICLEUR MARCHA LENTA C/TUBO SOLEX 2E7/3E<br/>SANTANA 1.8 GASOLINA - 175.206/67,5x140</p>              | <p><b>52.693</b></p>  <p>GICLEUR MARCHA LENTA C/TUBO SOLEX 2E7/3E<br/>PAMPA/ VERSALES/ ROYALE 1.8 ÁLCOOL - 175.214/65x155</p>               |
| <p><b>52.694</b></p>  <p>GICLEUR MARCHA LENTA C/TUBO SOLEX 2E7/3E<br/>ESCORT/ VERONA/ APOLLO/ MONZA ÁLCOOL - 176.216/82x160</p>  | <p><b>52.697</b></p>  <p>GICLEUR MARCHA LENTA C/TUBO SOLEX 2E7/3E<br/>FORD 89 GASOLINA - 175.208/52x150</p>                         |  |  |

**305 GICLEUR DE M LENTA C/ TUBO BLFA \*EMBALAGEM 10UN PREÇO UN\***















**305 GICLEUR DE M LENTA C/ TUBO BLFA \*EMBALAGEM 10UN PREÇO UN\***

|   |   |   |   |
|---|---|---|---|
| <p><b>52.700</b></p> <p>GICLEUR MARCHA LENTA C/TUBO SOLEX 30-34 GML BLFA<br/>FORD 91/.. 1.6 GASOLINA - Furo 55x135 - 130.135-55</p>   | <p><b>52.701</b></p> <p>GICLEUR MARCHA LENTA C/TUBO SOLEX 30-34 GML BLFA<br/>FORD 85/.. 1.6 ÁLCOOL - Furo 65x140 - 130.140-65</p> | <p><b>52.702</b></p> <p>GICLEUR MARCHA LENTA C/TUBO SOLEX 30-34 GML BLFA<br/>VW 89/.. 1.6 ÁLCOOL - Furo 80x135 - 130.135-80</p>       | <p><b>52.703</b></p> <p>GICLEUR MARCHA LENTA C/TUBO SOLEX 30-34 GML BLFA<br/>VW 89/.. 1.6 GASOLINA - Furo 57,5x140 - 130.140-57,5</p> |
| <p><b>52.704</b></p> <p>GICLEUR MARCHA LENTA C/TUBO SOLEX 30-34 GML BLFA<br/>GM 85/.. 1.8 ÁLCOOL - Furo 62,5x140 - 130.140-62,5</p>   | <p><b>52.705</b></p> <p>GICLEUR MARCHA LENTA C/TUBO SOLEX 30-34 GML BLFA<br/>GM 85/1.8- ÁLCOOL - Furo 65x120 - 130.120-65</p>     | <p><b>52.706</b></p> <p>GICLEUR MARCHA LENTA C/TUBO SOLEX 30-34 GML BLFA<br/>GM 85/.. 1.8 GASOLINA - Furo 67,5x140 - 130.140-67,5</p> | <p><b>52.707</b></p> <p>GICLEUR MARCHA LENTA C/TUBO SOLEX 30-34 GML BLFA<br/>VW 92/.. 1.6 GASOLINA - Furo 55x140 - 130.140-55</p>     |
| <p><b>52.708</b></p> <p>GICLEUR MARCHA LENTA C/TUBO SOLEX 30-34 GML BLFA<br/>VW 92/.. 1.6 GASOLINA - Furo 57,5x150 - 130.150-57,5</p> | <p><b>52.709</b></p> <p>GICLEUR MARCHA LENTA C/TUBO SOLEX 30-34 GML BLFA<br/>FORD 91/.. 1.6 ÁLCOOL - Furo 80x140 - 130.140-80</p> |   |   |

**310 TUBO MISTURADOR \*EMBALAGEM 10UN PREÇO UN\***

|   |   |   |  |
|---|---|---|--|
| <p><b>53.050</b></p> <p>TUBO MISTURADOR WEBER 495 TLDZ - 314.800.02<br/>PASSAT/VOYAGE/PARATI/GOL 1.6 &gt;89 ÁLCOOL/GASOLINA-B-1</p> | <p><b>53.051</b></p> <p>TUBO MISTURADOR WEBER 190 E 450 MINI - 316.500.02<br/>CHEVETTE 1.4/CORCEL III/BELINA/DEL REY/OGGI 1300 &gt;80/ÁLCOOL/GASOLINA-B-2</p> | <p><b>53.052</b></p> <p>TUBO MISTURADOR WEBER 450 MINI - 318.100.02<br/>PASSAT/VOYAGE/PARATI 1.6 &gt;83/ÁLCOOL/GASOLINA-B-3</p> | <p><b>53.053</b></p> <p>TUBO MISTURADOR WEBER 450 MINI - 318.800.02<br/>PASSAT/VOYAGE/PARATI 1.6/CHEVETTE 1.4 &gt;83/ÁLCOOL/GASOLINA-B-4</p> |
| <p><b>53.054</b></p> <p>TUBO MISTURADOR WEBER 450 MINI - 320.800.02<br/>PASSAT TS &gt;77/SANTANA/GOL/VOYAGE &gt;89/GASOLINA-B-5</p> | <p><b>53.055</b></p> <p>TUBO MISTURADOR WEBER 450 MINI - 321.900.02<br/>PASSAT/VOYAGE/PARATI 1.6/GOL &gt;81 ÁLCOOL-B-6</p>                                    | <p><b>53.057</b></p> <p>TUBO MISTURADOR WEBER 190 SIMPLES - 322.600.02<br/>MONZA 1.6 &gt;83/ÁLCOOL-B-10</p>                     | <p><b>53.058</b></p> <p>TUBO MISTURADOR WEBER 450 MINI - 327.700.02<br/>PASSAT/VOYAGE/PARATI 1.6/GOL &gt;84/GASOLINA-B-11</p>                |
| <p><b>53.059</b></p> <p>TUBO MISTURADOR WEBER 450 MINI - 327.800.02<br/>PASSAT/VOYAGE/PARATI 1.6/GOL &gt;84/GASOLINA-B-12</p>       | <p><b>53.060</b></p> <p>TUBO MISTURADOR WEBER 460 CHT - 328.300.02<br/>UNO SX 1300 &gt;84/ÁLCOOL-B-13</p>   | <p><b>53.062</b></p> <p>TUBO MISTURADOR WEBER 460 CHT - 341.100.02<br/>TEMPRA 2.0/UNO MILLE BRIO &gt;91/GASOLINA-B-15 LONGO</p> | <p><b>53.063</b></p> <p>TUBO MISTURADOR WEBER 460 CHT - 341.200.02<br/>TEMPRA 2.0/UNO MILLE BRIO &gt;91/ÁLCOOL/GASOLINA-B-16 LONGO</p>       |

**310 TUBO MISTURADOR \*EMBALAGEM 10UN PREÇO UN\***

|   |   |   |   |
|---|---|---|---|
| <p><b>53.064</b></p>  <p>TUBO MISTURADOR WEBER 460 CHT - 341.800.02 - B 17<br/>LOGUS/ESCORT/VERONA/GOL 1000/GOL1.6/VOYAGE/PARATI/SAVEIRO</p>               | <p><b>53.066</b></p>  <p>TUBO MISTURADOR WEBER 495 TLDZ - 342.500.02<br/>UNO MILLE &gt;93/GASOLINA-B-24</p>                | <p><b>53.067</b></p>  <p>TUBO MISTURADOR WEBER 460 CHT - 341.800.02-26<br/>GOL 1000 &gt;92/GASOLINA-B-26 LONGO</p>                              | <p><b>53.100</b></p>  <p>TUBO MISTURADOR WEBER 190 - 319.300.02<br/>FIAT 147 1050 77 À 82/GASOLINA-F-2</p>   |
| <p><b>53.101</b></p>  <p>TUBO MISTURADOR WEBER 460 CHT - 324.900.02<br/>CORCEL II/BELINA II/ESCORT/UNO SX &gt;83/ÁLCOOL/GASOLINA-F-22</p>                  | <p><b>53.102</b></p>  <p>TUBO MISTURADOR WEBER 460 CHT - 328.700.02<br/>CHEVETTE 1.6 &gt;87/ÁLCOOL-F-24 LONGO</p>          | <p><b>53.103</b></p>  <p>TUBO MISTURADOR WEBER 495 TLDZ (F-24 CURTO) - 341.600.02<br/>ESCORT 1.8 &gt;83 ELETR/GOL/PARATI/VOYAGE/SAVEIRO 1.8</p> | <p><b>53.104</b></p>  <p>TUBO MISTURADOR WEBER 460 CHT - 325.100.02<br/>CHEVETTE 1.6/CORCEL II/BELINA/ESCORT/PAMPA/UNO &gt;87/ÁLCOOL-F-25</p>                |
| <p><b>53.105</b></p>  <p>TUBO MISTURADOR WEBER 495 TLDZ (CURTO) - 340.700.02<br/>FIAT UNO 1.6/ELBA/PRÊMIO &gt;89/ÁLCOOL-F-25 CURTO</p>                     | <p><b>53.106</b></p>  <p>TUBO MISTURADOR WEBER 60 CHT - 327.000.02<br/>CORCEL/BELINA II/DEL REY/PAMPA/SCALA/ESCORT 1.6</p> | <p><b>53.107</b></p>  <p>TUBO MISTURADOR WEBER 460 CHT - 325.200.02<br/>UNO/CORCEL II/BELINA II/ESCORT/PAMPA/DEL REY &gt;83/GASOLINA-F-30</p>   | <p><b>53.108</b></p>  <p>TUBO MISTURADOR WEBER 460 CHT - 325.000.02<br/>CHEVETTE/CORCEL II/BELINA II/DEL REY/PAMPA/SCALA/ESCORT 1.6 &gt;83/GASOLINA-F-36</p> |
| <p><b>53.110</b></p>  <p>TUBO MISTURADOR WEBER 460 CHT - 331.000.02<br/>CORCEL II/BELINA II/DEL REY/PAMPA/SCALA/ESC. 1.6 &gt;84/ÁLCOOL/GASOLINA-F-39</p> | <p><b>53.112</b></p>  <p>TUBO MISTURADOR WEBER 460 CHT - 332.200.02<br/>CHEVETTE 1.6 &gt;87/ÁLCOOL-F-43</p>              | <p><b>53.113</b></p>  <p>TUBO MISTURADOR WEBER 460 CHT - 388.600.02<br/>FIAT 1.5/PRÊMIO/ELBA &gt;89/ÁLCOOL/GASOLINA-F-44</p>                  | <p><b>53.114</b></p>  <p>TUBO MISTURADOR WEBER 495 TLDZ - 339.900.02<br/>UNO 1.6R/PRÊMIO/ELBA/PICK-UP LX/UNO MILLE &gt;89/GASOLINA-F-50 CURTO</p>          |
| <p><b>53.115</b></p>  <p>TUBO MISTURADOR WEBER 495 TLDZ - 341.300.02<br/>GOL/VOYAGE/PARATI 1.6 E 1.8/LOGUS &gt;91/ÁLCOOL/GASOLINA-F-66 CURTO</p>         | <p><b>53.116</b></p>  <p>TUBO MISTURADOR WEBER 190 - 323.300.02<br/>FIAT OGGI 1300 &gt;83/GASOLINA-F-73</p>              | <p><b>53.117</b></p>  <p>TUBO MISTURADOR WEBER 495 TLDZ - 340.200.02<br/>FIAT UNO A.6/ELBA/PRÊMIO/FIORINO &gt;89/ÁLCOOL-F-74</p>              | <p><b>53.118</b></p>  <p>TUBO MISTURADOR WEBER 460 CHT - 323.200.02<br/>FIAT UNO SX 1300 &gt;85/GASOLINA-F-86</p>  |

**315 TUBO MISTURADOR BLFA \*VENDIDO EM PARES - VALOR DO PAR\***

|  |  |   |   |
|--|--|---|---|
| <p><b>52.821</b></p>  <p>TUBO MISTURADOR CARB. SOLEX 30-34 BLFA - 130-502/21/24/25-1° CORPO<br/>CORCEL/BELINA 83 À 88/ DEL REY 83 À 88/PAMPA 83 À 89/ÁLCOOL/130x170</p> | <p><b>52.822</b></p>  <p>TUBO MISTURADOR CARB. SOLEX 30-34 BLFA - 130-528-1° CORPO<br/>ESCORT 91/VERONA/GASOLINA/97x130</p> | <p><b>52.823</b></p>  <p>TUBO MISTURADOR CARB. SOLEX 30-34 BLFA - 130-529-1° CORPO<br/>ESCORT 83 À 88/VERONA 90 À 91/ÁLCOOL/125x175</p> | <p><b>52.824</b></p>  <p>TUBO MISTURADOR CARB. SOLEX 30-34 BLFA - 130-532-1° CORPO<br/>VOYAGE 89 À 91/PARATI 89 À 91/SAVEIRO 91/GASOLINA/107x180</p> |
|--|--|---|---|





**315 TUBO MISTURADOR BLFA \*VENDIDO EM PARES - VALOR DO PAR\***

|   |   |  |  |
|---|---|--|--|
| <p><b>52.825</b></p>  <p>TUBO MISTURADOR CARB. SOLEX 30-34<br/>BLFA - 130-533-1° CORPO<br/>VOYAGE 89 À 91/PARATI 91/SAVEIRO 89 À<br/>91/GASOLINA/102x175</p> | <p><b>52.826</b></p>  <p>TUBO MISTURADOR CARB. SOLEX 30-34<br/>BLFA - 130-526/27-1° CORPO<br/>GOL GT GTS 84 À 85/GOL/PARATI/SAVEIRO 89 À<br/>91/ÁLCOOL/127,5x175</p> | <p><b>52.827</b></p>  <p>TUBO MISTURADOR CARB. SOLEX 30-34<br/>BLFA - 130-504/41-1° CORPO<br/>MONZA 1.8 85 À 86/ÁLCOOL/135x180</p> | <p><b>52.828</b></p>  <p>TUBO MISTURADOR CARB. SOLEX 30-34<br/>BLFA - 130-503-1° CORPO<br/>MONZA 85 À 86/GASOLINA/110x140</p> |
| <p><b>52.829</b></p>  <p>TUBO MISTURADOR CARB. SOLEX 30-34<br/>BLFA - 130-506-1° CORPO<br/>GOL/VOYAGE 1.6<br/>10/92/PARATI/SAVEIRO/GASOLINA/100x170</p>      | <p><b>52.830</b></p>  <p>TUBO MISTURADOR CARB. SOLEX 30-34<br/>BLFA - 130-507-1° CORPO<br/>GOL/VOYAGE 1.6<br/>10/92/PARATI/SAVEIRO/ÁLCOOL/127,5x175</p>              |  |  |

**320 PORTA GICLEUR \*EMBALAGEM 10UN PREÇO UN\***

|  |   |   |  |
|--|---|---|--|
| <p><b>52.907</b></p>  <p>PORTA GICLEUR PRINCIPAL CARB. SOLEX<br/>VW<br/>2814</p>   | <p><b>52.907-MJ</b></p>  <p>PORTA GICLEUR PRINCIPAL CARB. SOLEX<br/>VW<br/>2814-MJ</p>  | <p><b>52.909</b></p>  <p>PORTA GICLEUR PRINCIPAL CARB. DUPLO<br/>WEBER 450 MINI VW/ GM/ FORD<br/>201.669.02</p>          | <p><b>52.911</b></p>  <p>PORTA GICLEUR PRINCIPAL CARB. DUPLO<br/>WEBER 228 DFV GM/ FORD<br/>402.150.02</p>               |
| <p><b>52.911-MJ</b></p>  <p>PORTA GICLEUR PRINCIPAL CARB. WEBER<br/>228 DFV GM/ FORD<br/>402.150.02-MJ</p>              | <p><b>52.917</b></p>  <p>PORTA GICLEUR M. LENTA CARB. WEBER<br/>450 E 190 MINI VW/ GM/ FORD (MOD.<br/>ANTIGO)<br/>461.105.22</p> | <p><b>52.920/070</b></p>  <p>PORTA GICLEUR M. LENTA CARB. WEBER<br/>460 CHT VW/ FIAT/ FORD VAZÃO 70<br/>332.507.02</p>  | <p><b>52.920/100</b></p>  <p>PORTA GICLEUR M. LENTA CARB. WEBER<br/>460 CHT VW/ FIAT/ FORD VAZÃO 100<br/>332.510.02</p> |
| <p><b>52.920/110</b></p>  <p>PORTA GICLEUR M. LENTA CARB. WEBER<br/>460 CHT VW/ FIAT/ FORD VAZÃO 110<br/>332.511.02</p> | <p><b>52.920/115</b></p>  <p>PORTA GICLEUR M. LENTA CARB. WEBER<br/>460 CHT VW/ FIAT/ FORD VAZÃO 115<br/>332.511.52</p>          | <p><b>52.920/150</b></p>  <p>PORTA GICLEUR M. LENTA CARB. WEBER<br/>460 CHT VW/ FIAT/ FORD VAZÃO 150<br/>332.515.02</p> |  |

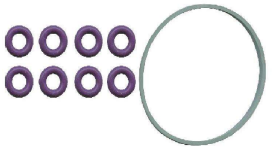
**325 JUNTAS INJ.ELETR. - CITROEN (SIMPLES)**

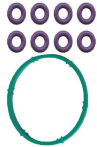
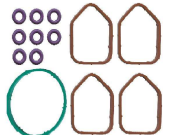
|  |   |  |   |
|--|---|--|---|
| <p><b>225083/3</b></p>  <p>JTAS.INJ. XSARA PICASSO GLX/EXCLUSIVE<br/>2.0 2001/MPI</p> | <p><b>225084/4</b></p>  <p>JTAS.INJ. XSARA PICASSO GLX/EXCL. 2.0<br/>2001/MPI C/ JTAS ADM.</p> | <p><b>225085/5</b></p>  <p>JTAS.INJ. BERLINGO 1.8 8V</p> | <p><b>225086/6</b></p>  <p>JTAS.INJ. BERLINGO 1.8 8V C/ JUNTAS DE<br/>ADM.</p> |
|--|---|--|---|



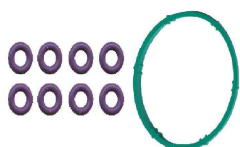
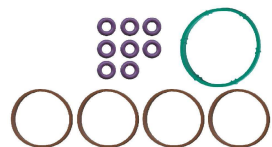
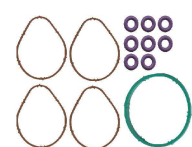

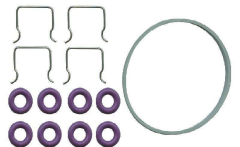
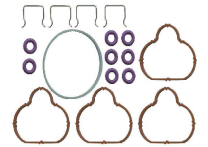
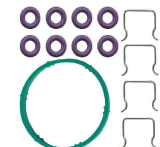
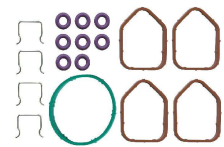
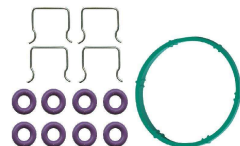
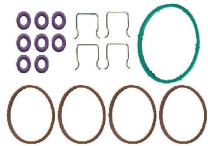
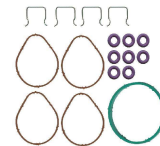

**325 JUNTAS INJ.ELETR. - CITROEN (SIMPLES)**

|  |  |  |  |
|--|--|--|--|
| <p><b>225087/7</b></p>  <p>JTAS.INJ. CITROEN XSARA 1.8/C3 1.6 16V</p> | <p><b>225088/8</b></p>  <p>JTAS.INJ. CITROEN C3 1.6 16V MPI C/ JUNTAS DE ADM.</p> | <p><b>225089/9</b></p>  <p>JTAS.INJ. CITROEN XSARA 1.8 16V C/ JUNTAS DE ADM.</p> |  |
|--|--|--|--|

**330 JUNTAS P/ INJ. ELETR. - CITROEN (COMPLETO)**

|   |  |   |   |
|---|--|---|---|
| <p><b>200083/3</b></p>  <p>JT.INJ.XSARA PICASSO GLX/EXCL. 2.0 2001/MPI</p> | <p><b>200084/4</b></p>  <p>JT.INJ.XSARA PICASSO GLX/EXCL. 2.0 2001/MPI C/JTAS ADM</p> | <p><b>200085/5</b></p>  <p>JT.INJ.BERLINGO 1.8 8V</p>                   | <p><b>200086/6</b></p>  <p>JT.INJ.BERLINGO 1.8 8V C/ JTA ADM</p> |
| <p><b>200087/7</b></p>  <p>JT.INJ.CITROEN XSARA 1.8/C3 1.6 16V</p>        | <p><b>200088/8</b></p>  <p>JT.INJ.CITROEN C3 1.6 16V MPI C/ COL ADM</p>              | <p><b>200089/9</b></p>  <p>JT.INJ.CITROEN XSARA 1.8 16V C/ JTA ADM</p> |   |

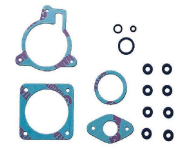
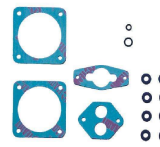
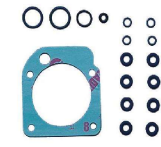
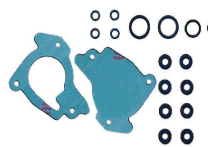
**335 JUNTAS INJ. ELETR. - FIAT (SIMPLES)**

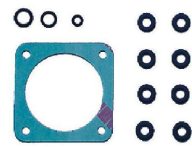
|  |  |  |  |
|--|--|--|--|
| <p><b>225002/2</b></p>  <p>JTAS INJ.UNO/PREM/ELBA 1.5/1.6 SPI</p>                     | <p><b>225005/5</b></p>  <p>JTAS INJ.TIPO I.E IMPORT.S/CALÇO MONO MOTRONIC</p> | <p><b>225005/C</b></p>  <p>JTAS INJ.TIPO I.E IMPORT. C/CALÇO MONO MOTRONIC</p> | <p><b>225009/9</b></p>  <p>JTAS INJ.TEMPRA 2000 I.E SIST. MARELLI G8 SP</p> |
| <p><b>225014/4</b></p>  <p>JTAS.INJ. FIAT TEMP. 2.0 16V. SIST. MARELLI G7 25 -MPI</p> | <p><b>225018/8</b></p>  <p>JTAS.INJ. TEMPRA 2.0 16V 94/ IAW P8 MPI</p>        | <p><b>225021/1</b></p>  <p>JTAS.INJ. TIPO 1.6/2.0 16V. SIST.BOSCH MPI</p>      | <p><b>225022/2</b></p>  <p>JTAS.INJ. PALIO 1.6 16V. IAW 1 AB MPI</p>        |
| <p><b>225023/3</b></p>  <p>JTAS.INJ. FIAT PALIO 1.0/1.5 8V.SIST.MARELLI MPI</p>       | <p><b>225025/5</b></p>  <p>JTAS.INJ. UNO MILLE EP 1.0 SIST.MARELLI G7 SPI</p> | <p><b>225028/8</b></p>  <p>JTAS.INJ. MAREA SW 2.0 20V. SIST. MARELLI -MPI</p>  | <p><b>225032/2</b></p>  <p>JTAS.INJ. TIPO 1.6 SIST.MARELLI M.P.I</p>        |











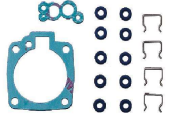
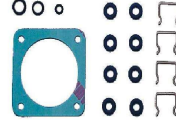

**335 JUNTAS INJ. ELETR. - FIAT (SIMPLES)**

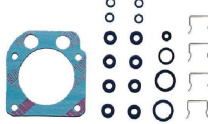
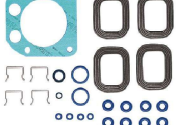
|   |  |   |   |
|---|--|---|---|
| <p><b>225034/4</b></p> <p>JTAS.INJ. UNO/PREM/ELBA 1.5/MILLE EP 1.0</p>                            | <p><b>225035/5</b></p> <p>JTAS.INJ. UNO A PARTIR DE DEZ.96 SIST.MARELLI SPI</p>      | <p><b>225036/6</b></p> <p>JTAS.INJ. PALIO 1.0/1.5 8V C/COLET. IAW MPI</p>   | <p><b>225037/7</b></p> <p>JTAS.INJ. SIENA/PALIO 1.6 SPI</p>                       |
| <p><b>225039/9</b></p> <p>JTAS.INJ. UNO/PREM/ELBA 1.5/1.6 ARGENTINO MPI</p>                       | <p><b>225063/3</b></p> <p>JTAS.INJ. UNO/PREM/ELBA 1.5/1.6 ARG</p>                    | <p><b>225068/8</b></p> <p>JTAS.INJ. PALIO/SIE/WEEK.ELX 1.0/1.3 16V FIRE</p> | <p><b>225069/9</b></p> <p>JTAS.INJ. PALIO/SIE/WEEK/FIRE 1.0/1.3 16 V C/COLET.</p> |
| <p><b>225070/0</b></p> <p>JTAS.INJ. UNO MILLE/PALIO/SIENA EX 1.0/1.3 8V</p>                       | <p><b>225071/1</b></p> <p>JTAS.INJ. UNO MILLE/PALIO/SIENA EX 1.0/1.3 8V C/COLET.</p> | <p><b>225100/1</b></p> <p>JTA. INJ. FIAT STILLO 1.8 - 16V</p>               | <p><b>225104/4</b></p> <p>JTA. INJ. FIAT STILLO ABARTH 2.4 20V 03/...</p>         |
| <p><b>225110/1</b></p> <p>JTAS.INJ. PALIO 1.6 16V 96/2000/PALIO WEEKEND SPORT 1.6 16V 97/2000</p> |  |   |   |



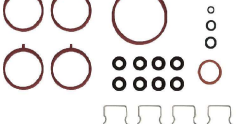

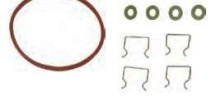
**340 JUNTAS P/ INJ. ELETR. - FIAT (COMPLETO)**

|  |  |  |   |
|--|--|--|---|
| <p><b>200002/2</b></p> <p>JT.INJ.UNO/PRÊMIO/ELBA 1.5/1.6-S.MARELLI G7</p>    | <p><b>200005/C</b></p> <p>JT.INJ. TIPO I.E IMP.C/CALÇO-S.BOSCH M.MOT</p> | <p><b>200009/9</b></p> <p>JT.INJ. TEMPRA 2000 I.E SIST.MARELLI G8</p>    | <p><b>200014/4</b></p> <p>JT.INJ. TEMPRA 2.0 16V-SIST.MARELLI G7 25</p> |
| <p><b>200018/8</b></p> <p>JT.INJ. TEMPRA 2.0 16V 94/SIST.MAR. IAW-P8-MPI</p> | <p><b>200021/1</b></p> <p>JT.INJ. TIPO 1.6/2.0 16V.SIST.BOSCH-MPI</p>    | <p><b>200022/2</b></p> <p>JT.INJ. PALIO 1.6 16V-SIST.MARELLI-IAW 1AB</p> | <p><b>200023/3</b></p> <p>JT.INJ. PALIO 1.0/1.5-8V-SIST.MARELLI-IAW</p> |

**340 JUNTAS P/ INJ. ELETR. - FIAT (COMPLETO)**

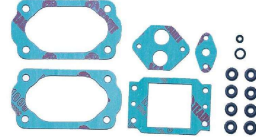

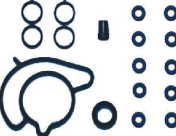
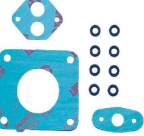

|  |  |   |   |
|--|--|---|---|
| <p><b>200025/5</b></p>  <p>JT.INJ. UNO MILLE EP 1.0-SIST.MARELLI G7</p>       | <p><b>200028/8</b></p>  <p>JT.INJ. MAREA SW 2.0-20V-SIST.MARELLI</p>          | <p><b>200032/2</b></p>  <p>JT.INJ. TIPO 1.6-SIST.MARELLI-MPI</p>                | <p><b>200034/4</b></p>  <p>JT.INJ.UNO/PREMIO/ELBA 1.5-MILLE EP-SIST.MAR.</p>                 |
| <p><b>200035/5</b></p>  <p>JT.INJ. UNO A PARTIR DEZ. 96-SIST.MARELLI</p>      | <p><b>200036/6</b></p>  <p>JT.INJ.PALIO 1.0/1.5 8V.C/COLETOR-SIST.MAR.</p>    | <p><b>200037/7</b></p>  <p>JT.INJ. SIENA/PALIO 1.6-SIST. MARELLI-SPI</p>        | <p><b>200039/9</b></p>  <p>JT.INJ.UNO/PREM/ELBA 1.5/1.6-MOT.ARG-S.B OSC</p>                  |
| <p><b>200063/3</b></p>  <p>JT.INJ. UNO/PREM/ELBA 1.5/1.6-ARG. C/BORR.</p>    | <p><b>200068/8</b></p>  <p>JT.INJ.PALIO/SIENA/WEEK. ELX 1.0/1.3 16V FIRE</p> | <p><b>200069/9</b></p>  <p>JT.INJ.PALIO/WEEK/SIENA 1.0/1.3-FIRE 16V C/COL.</p> | <p><b>200070/0</b></p>  <p>JT.INJ.UNO MIL/PALIO/SIENA EX 1.0/1.3 FIRE 8V</p>                |
| <p><b>200071/1</b></p>  <p>JT.INJUNO MIL/PAL/SIENA EX 1.0/1.3 FIRE 8V/C</p> | <p><b>200100/1</b></p>  <p>JT.INJ. STILLO 1.8 16V</p>                       | <p><b>200104/4</b></p>  <p>JT.INJ. STILLO ABARTH 2.4 20V 03/...</p>           | <p><b>200110/1</b></p>  <p>JT.INJ.PALIO 1.6 16 V 96/2000/ P.WEEK.SPORT 1.6 16V 97/2000</p> |

**345 JUNTAS INJ. ELETR. - FORD (SIMPLES)**



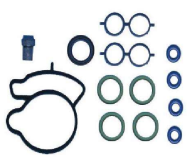
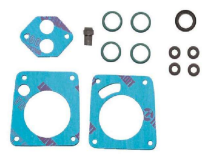

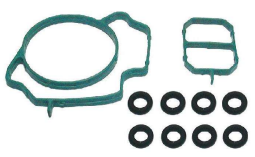
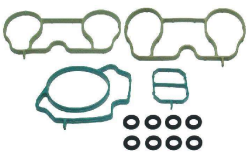
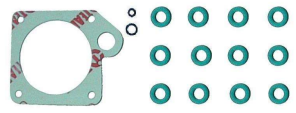
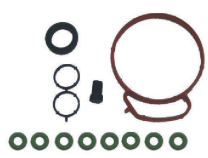
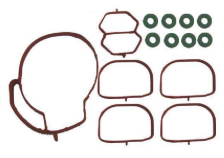
|  |  |  |   |
|--|--|--|---|
| <p><b>225007/7</b></p>  <p>JTAS.INJ.ESCORT/VER/VERS/ROY. 1.8 SIST.FIC VISTEON</p> | <p><b>225013/3</b></p>  <p>JTAS.INJ. ESCORT XR3/VER/VERS/ROY/2.0 MPFI</p>   | <p><b>225017/7</b></p>  <p>JTAS.INJ. FIESTA 1.3 IMPORT. S/CALCO VISTEON EEC IV SPI</p> | <p><b>225017/C</b></p>  <p>JTAS.INJ. FIESTA 1.3 IMPORT.C/CALCO SPI</p>     |
| <p><b>225041/1</b></p>  <p>JTAS.INJ. FIESTA/KA 1.0/1.3 ENDURA MPFI</p>            | <p><b>225048/8</b></p>  <p>JTAS.INJ. FORD RANGER 4CIL. 2.3/2.5 OHC MPFI</p> | <p><b>225049/9</b></p>  <p>JTAS.INJ. FORD F-1000 4.9 06 CIL.MPFI</p>                   | <p><b>225054/4</b></p>  <p>JTAS.INJ. ESCORT/ SWAGON ZETEC 1.8 16V.MPFI</p> |

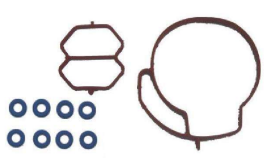
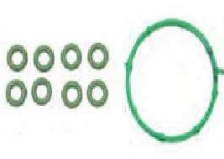
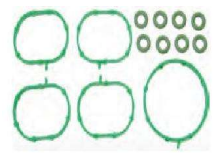



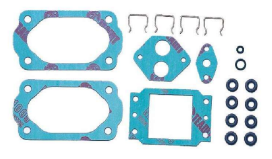

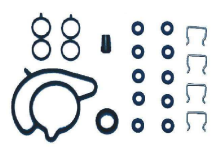
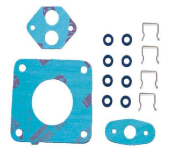

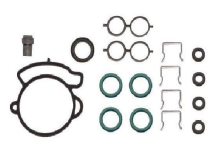
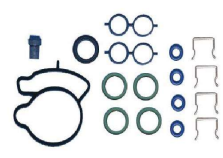
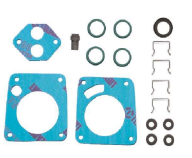
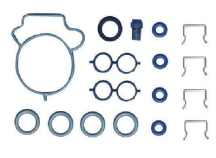
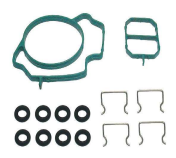
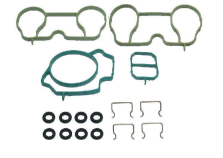
**345 JUNTAS INJ. ELETR. - FORD (SIMPLES)**

|   |  |  |  |
|---|--|--|--|
| <p><b>225055/5</b></p>  <p>JTAS.INJ. FIESTA CLX / KA/ COUR/ ZETEC 16V.MPI</p>                  | <p><b>225059/9</b></p>  <p>JTAS.INJ. FORD MONDEO 2.0 4CIL. ZETEC 16V. MPI</p> | <p><b>225064/4</b></p>  <p>JTAS.INJ. KA 1.0/COUR. 1.6/ESCT 2000 ZETEC ROCAN 16V.</p> | <p><b>225072/2</b></p>  <p>JTAS.INJ. FORD FIESTA/ ECO SPORT S/COLET.</p>            |
| <p><b>225073/3</b></p>  <p>JTAS.INJ. FORD FIESTA/ECO SPORT C/COLET.</p>                        | <p><b>225074/4</b></p>  <p>JTAS.INJ. FORD RANGER 4.0L 94/95 S/COLET.</p>      | <p><b>225098/8</b></p>  <p>JTA. INJ. FORD FOCUS 1.8/2.0 - 16V 2001/... ZETEC MPI</p> | <p><b>225105/5</b></p>  <p>JTA. INJ. FORD ECO SPORT 2.0 2003/... DURATEC C/ADM.</p> |
| <p><b>225106/6</b></p>  <p>JTA. INJ. FORD FOCUS 1.8/2.0 16V 2001/... ZETEC MPI C/ADMISSÃO</p> | <p><b>225107/7</b></p>  <p>JTA. INJ. FORD ECO SPORT 2.0 2003/... DURATEC</p> | <p><b>225117/7</b></p>  <p>JT.INJ.FORD NEW FIESTA</p>                               | <p><b>225118/8</b></p>  <p>JT.INJ.FORD NEW FIESTA C/ COLETORES</p>                 |

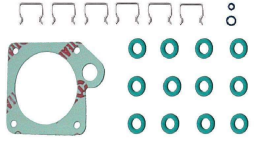

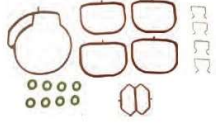

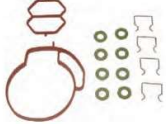







**350 JUNTAS P/ INJ. ELETR. - FORD (COMPLETO)**

|   |  |  |  |
|---|--|--|--|
| <p><b>200007/7</b></p>  <p>JT.INJ.ESC/VER/VERS/ROYALE 1.8-S.FIC VIST.EEC IV</p>  | <p><b>200013/3</b></p>  <p>JT.INJ.ESC. XR3/VER/VERS/ROY.2.0-SIST.BOSCH</p>  | <p><b>200017/C</b></p>  <p>JT.INJ.FIESTA 1.3 IMPORT.C/CALÇO-SIST.FIC-SPI</p> | <p><b>200041/1</b></p>  <p>JT.INJ.FIESTA/KA 1.0/1.3- ENDURA-SIST. MPI</p> |
| <p><b>200048/8</b></p>  <p>JT.INJ.RANGER 4CIL.2.3/2.5 MOT. OHC-SIST.MPI</p>      | <p><b>200049/9</b></p>  <p>JT.INJ.F-1000 4.9 06 CIL.MPI</p>                 | <p><b>200054/4</b></p>  <p>JT.INJ.ESC/S WAGON- ZETEC 1.8 16V.-SIST.MPI</p>   | <p><b>200055/5</b></p>  <p>JT.INJ.FIESTA CLX/KA/COURIER-ZETEC 1.4 16V</p> |
| <p><b>200059/9</b></p>  <p>JT.INJ.MONDEO 2.0 4CIL.-ZETEC 16V. - SIST.M.POINT</p> | <p><b>200064/4</b></p>  <p>JT.INJ.KA 1.0/COUR.1.6/ESC.2000-Z..ROCAN 16V</p> | <p><b>200072/2</b></p>  <p>JT.INJ.FORD FIESTA/ECO SPORT S/COLETOR</p>        | <p><b>200073/3</b></p>  <p>JT.INJ.FORD FIESTA/ECO SPORT C/COLETOR</p>     |

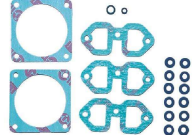
**350 JUNTAS P/ INJ. ELETR. - FORD (COMPLETO)**

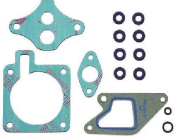
|  |   |  |  |
|--|---|--|--|
| <p><b>200074/4</b></p>  <p>JT.INJ.FORD RANGER 4.0L 94/95 S/COLETOR</p>      | <p><b>200098/8</b></p>  <p>JT.INJ. FORD FOCUS 1.8-2.0 16V 2001/... ZETEC</p> | <p><b>200105/5</b></p>  <p>JT.INJ.FORD ECO SPORT 2.0-2003/... DURAT. C/ ADM.</p> | <p><b>200106/6</b></p>  <p>JT.INJ.FORD FOCUS 1.8-2.0 16V 2001/... ZET.C/ ADM.</p> |
| <p><b>200107/7</b></p>  <p>JT.INJ.FORD ECO SPORT 2.0 - 2003/... DURATEC</p> | <p><b>200117/7</b></p>  <p>JT.INJ.FORD NEW FIESTA</p>                        | <p><b>200118/8</b></p>  <p>JT.INJ.FORD NEW FIESTA C/ COLETORES</p>               |  |

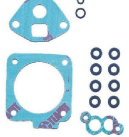
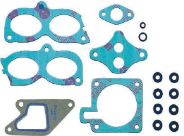
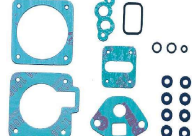
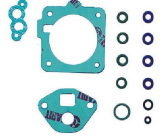





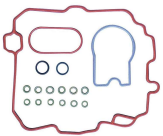
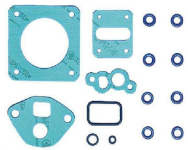
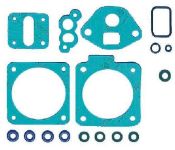
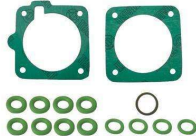
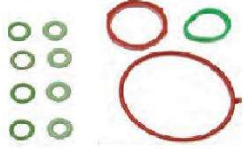
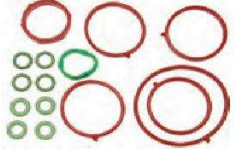

**355 JUNTAS INJ. ELETR. - GM (SIMPLES)**

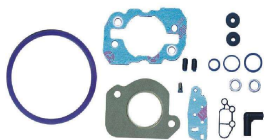
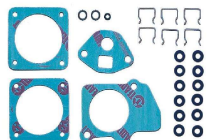
|   |   |  |  |
|---|---|--|--|
| <p><b>225001/1</b></p>  <p>JTAS INJ.MONZA/KADET/IPAN/S10 1.8/2.0 EFI</p>            | <p><b>225001/3</b></p>  <p>JTAS INJ.MONZA/KADT/IPAN/S10 1.8/2.0 C/ BORR.</p>          | <p><b>225003/3</b></p>  <p>JTAS INJ.OMEGA/SUPR.3.1 6 CIL. MOTRONIC MPFI</p>           | <p><b>225006/6</b></p>  <p>JTAS INJ.MZA/KADET GSI VECT/OME.2.0 4CIL MPFI</p>             |
| <p><b>225010/1</b></p>  <p>JTAS INJ.CORSA WIND 1.0/ GL 1.4/PICK-UP/EFI</p>         | <p><b>225010/2</b></p>  <p>JTAS INJ.CORSA WIND 1.0/GL 1.4/SEDAN 1.4/1.6 C/ BORR.</p> | <p><b>225012/2</b></p>  <p>JTAS.INJ. OMEGA/SUPR.CD 3.0 6CIL.MULTEC MPFI</p>          | <p><b>225016/6</b></p>  <p>JTAS.INJ. CORSA WIND/SEDAN/GL 1.0/1.4/1.6 MULTEC MPFI</p>    |
| <p><b>225019/9</b></p>  <p>JTAS.INJ. VECTRA GSI/CALIBRA 2.0 16V.MOTRONIC MPFI</p>  | <p><b>225024/4</b></p>  <p>JTAS.INJ. CORSA SEDAN 1.6 GSI 16V.MULTEC MPFI</p>         | <p><b>225029/9</b></p>  <p>JTAS.INJ. PICK-UP SILVER/OMEGA 4.1 6CIL MOTRONIC MPFI</p> | <p><b>225031/1</b></p>  <p>JTAS.INJ. VECTRA/ S10/ BLAZ. 2.0/2.2 GLS 8V MULTEC MPFI</p>  |
| <p><b>225045/5</b></p>  <p>JTAS.INJ. CORSA GSI/SEDAN/ WAGON 16V MPFI-C/ COLET.</p> | <p><b>225047/7</b></p>  <p>JTAS.INJ. VECT.2.0/2.2/AST.2.0/OME. 2.0 16V 1.5 MPFI</p>  | <p><b>225061/1</b></p>  <p>JTAS.INJ. CELTA 1.0/CORSA WIND1.0/CORSA 1.6</p>           | <p><b>225062/2</b></p>  <p>JTAS.INJ. CORSA WIND 1.0/CORSA1.6 16V.MPI 99/...SIST.MPI</p> |

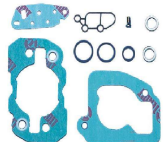
**355 JUNTAS INJ. ELETR. - GM (SIMPLES)**

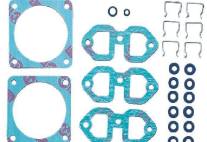
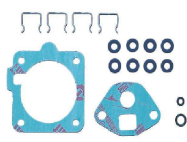

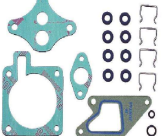
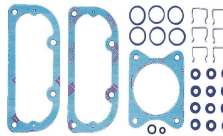
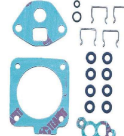
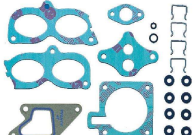
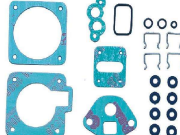
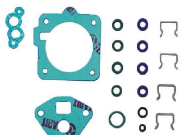
|  |   |  |  |
|--|---|--|--|
| <p><b>225065/5</b></p>  <p>JTAS.INJ. S10/BLAZER C/MOT. 4.3 3L V6<br/>SIST.ROCHESTER</p> | <p><b>225066/6</b></p>  <p>JTAS.INJ. ASTRA 1.8 8 V99/SIST.BOSCH MPI</p>                              | <p><b>225067/7</b></p>  <p>JTAS.INJ. VECT.GLS/S10/BLAZER 2.2<br/>8V.99/..SIST.BOSCH MPFI</p> | <p><b>225097/7</b></p>  <p>JUNTA INJ. GM CORSA 96/HATCH/SEDAN<br/>W.SUPER/PICK-UP 99 1.0 GAS/1.3ALC./1.6<br/>MPFI</p> |
| <p><b>225113/3</b></p>  <p>JTAS INJ.GM CORSA/MERIVA/MONTANA<br/>2006/ 1.8 8V FLEX</p>   | <p><b>225114/4</b></p>  <p>JTAS INJ.GM CORSA/MERIVA/MONTANA<br/>2006/ 1.8 8V FLEX C/ COLETOR ADM</p> |  |  |

**360 JUNTAS P/ INJ. ELETR.- GM (COMPLETO)**

|  |   |   |   |
|--|---|---|---|
| <p><b>200001/1</b></p>  <p>JT.INJ. GM MONZA/KAD/IPAN/S10 1.8/2.0<br/>S.ROC</p>   | <p><b>200001/3</b></p>  <p>JT.INJ GM MON/KAD/IPAN/S10 1.8/2.0<br/>S.R.-C/B</p>    | <p><b>200003/3</b></p>  <p>JT.INJ. GM OM/SUPRE. 3.1 6CIL/BOSCH<br/>MOTRO</p>     | <p><b>200006/6</b></p>  <p>JT.INJ. MZA/KADET GSI VECT/OME.2.0 4CIL<br/>MPFI</p>   |
| <p><b>200010/1</b></p>  <p>JT.INJ CORSA<br/>WIND1.0/GL1.4/PICK.SED1.4/1.6</p>   | <p><b>200010/2</b></p>  <p>JT.INJ COR.WIND1.0/GL1.4/PICK/SED1.4/1.6<br/>C/B.</p> | <p><b>200012/2</b></p>  <p>JT.INJ. OMEGA/SUPRE. CD 3.0 6CIL.-ROCH.</p>          | <p><b>200016/6</b></p>  <p>JT.INJ.CORSA WIND/SED/GL 1.0/1.4/1.6-S.RO</p>         |
| <p><b>200019/9</b></p>  <p>JT.INJ.VEC.GSI/CALIB.2.0 16.-SIST.BOSCH<br/>MOT.</p> | <p><b>200024/4</b></p>  <p>JT.INJ.COR.SED1.6 GSI 16V- MOT.POWERT<br/>S.ROC</p>   | <p><b>200029/9</b></p>  <p>JT.INJ. PICK UP SILV/OM 4.1 6CIL- S.BOSCH</p>        | <p><b>200031/1</b></p>  <p>JT.INJ. VEC/S10/BLAZER 2.0/2.2 GLS<br/>8V-S.ROCH.</p> |
| <p><b>200045/5</b></p>  <p>JT.INJ. CORSA GSI/SED/WAGON<br/>16V-S.M.P.C/COL</p>  | <p><b>200047/7</b></p>  <p>JT.INJ.VEC.2.0-2.2/ASTRA 2.0/OM 2.0<br/>16V-BOSC.</p> | <p><b>200061/1</b></p>  <p>JT.INJ.CORSA 1.0/1.6 8V.MPI 99/.../CELTA<br/>1.0</p> | <p><b>200062/2</b></p>  <p>JT.INJ. CORSA 1.0/1.6 16V MPFI ANO 99</p>             |

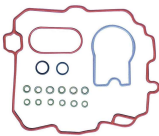
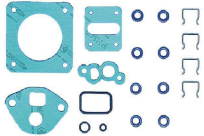
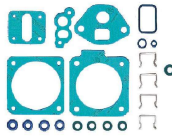
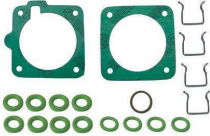

**360 JUNTAS P/ INJ. ELETR.- GM (COMPLETO)**

|  |   |   |   |
|--|---|---|---|
| <p><b>200065/5</b></p>  <p>JT.INJ. S10/BLAZER C/MOT.4.3L<br/>V6-SIST.ROCH.</p>      | <p><b>200066/6</b></p>  <p>JT.INJ. ASTRA 1.8-08 VALV.<br/>99/...SIST.BOSCH</p>                     | <p><b>200067/7</b></p>  <p>JT.INJ. VEC.GLS/S10/BLAZER 2.2<br/>8V.99/S.BOSCH</p> | <p><b>200097/7</b></p>  <p>JT.INJ.GM CORSA<br/>96/HAT/SED.WINDSUP/PICK-UP 99 1.0</p> |
| <p><b>200113/3</b></p>  <p>JT.INJ.GM CORSA/MERIVA/MONTANA 2006/<br/>1.8 8V FLEX</p> | <p><b>200114/4</b></p>  <p>JT.INJ.GM CORSA/MERIVA/MONTANA 2006/<br/>1.8 8V FLEX C/ COLETOR ADM</p> |   |   |



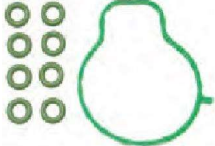
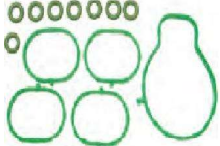

**365 JUNTAS P/ INJ. ELETR. - HONDA (SIMPLES)**

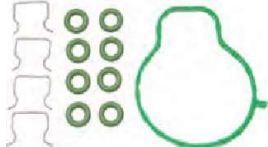
|  |   |  |  |
|--|---|--|--|
| <p><b>225119/9</b></p>  <p>JTAS INJ.HONDA CIVIC 2005</p> | <p><b>225120/0</b></p>  <p>JTAS INJ.HONDA CIVIC 2005 C/ COLETORES</p> |  |  |
|--|---|--|--|

**370 JUNTAS P/ INJ. ELETR. - HONDA (COMPLETO)**

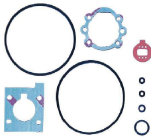
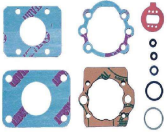
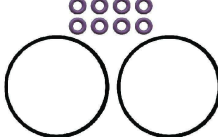
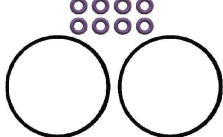
|   |  |  |  |
|---|--|--|--|
| <p><b>200119/9</b></p>  <p>JT.INJ.HONDA CIVIC 2005</p> | <p><b>200120/0</b></p>  <p>JT.INJ.HONDA CIVIC 2005 C/ COLETORES</p> |  |  |
|---|--|--|--|

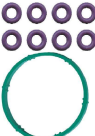
**375 JUNTAS INJ. ELETR. - PEUGEOT (SIMPLES)**

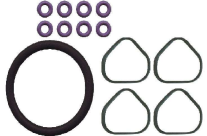



|   |   |  |  |
|---|---|--|--|
| <p><b>225050/0</b></p>  <p>JTAS.INJ. PEUGEOT 205 /405 SPI</p>                          | <p><b>225056/6</b></p>  <p>JTAS.INJ. PEUGEOT 205 XSI 1.4<br/>SIST.BOSCH -SPI</p> | <p><b>225090/0</b></p>  <p>JTAS.INJ. PEUGEOT 206 1.6 8V MPI</p>  | <p><b>225091/1</b></p>  <p>JTAS.INJ. PEUGEOT 206 1.6 8V MPI C/<br/>JUNTAS DE ADMISSAO</p> |
| <p><b>225092/2</b></p>  <p>JTAS.INJ. PEUGEOT 206 1.6 16V MPI C/<br/>JUNTAS DE ADM.</p> | <p><b>225093/3</b></p>  <p>JTAS.INJ. PEUGEOT 206 1.6 16V MPI</p>                 | <p><b>225094/4</b></p>  <p>JTAS.INJ. PEUGEOT 206 1.0 16V MPI</p> | <p><b>225095/5</b></p>  <p>JTAS.INJ. PEUGEOT 206 1.0 16V MPI C/<br/>JUNTAS DE ADM.</p>    |

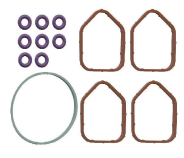



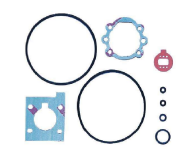

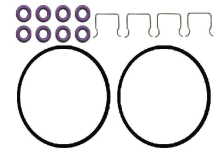
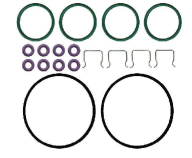
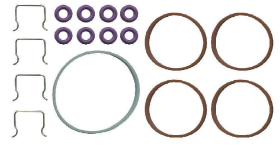
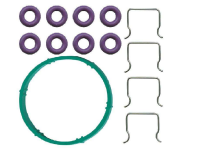

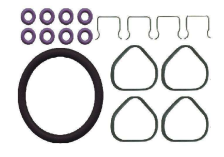
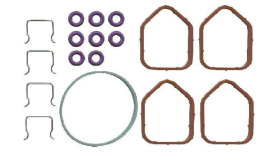

**375 JUNTAS INJ. ELETR. - PEUGEOT (SIMPLES)**

|   |  |  |  |
|---|--|--|--|
| <p><b>225096/6</b></p>  <p>JTAS.INJ. PEUGEOT PARTNER 1.8<br/>8V-C/JTA.ADM.</p> |  |  |  |
|---|--|--|--|

**380 JUNTAS P/ INJ. ELETR. - PEUGEOT (COMPLETO)**

|   |  |  |  |
|---|--|--|--|
| <p><b>200050/0</b></p>  <p>JT.INJ.PEUGEOT 205/405 SPI SIST.BOSCH</p>             | <p><b>200056/6</b></p>  <p>JT.INJ.PEUGEOT 205 XSI 1.4 SPI<br/>SIST.BOSCH</p>  | <p><b>200090/0</b></p>  <p>JT.INJ.PEUGEOT 206 1.6 8V MPI</p>   | <p><b>200091/1</b></p>  <p>JT.INJ.PEUGEOT 206 1.6 8V MPI C/ JTAS<br/>ADM</p>  |
| <p><b>200092/2</b></p>  <p>JT.INJ.PEUGEOT 206 1.6 16V MPI</p>                   | <p><b>200093/3</b></p>  <p>JT.INJ.PEUGEOT 206 1.6 16V MPI C/ JTA<br/>ADM</p> | <p><b>200094/4</b></p>  <p>JT.INJ.PEUGEOT 206 1.0 16V MPI</p> | <p><b>200095/5</b></p>  <p>JT.INJ.PEUGEOT 206 1.0 16V MPI C/ JTA<br/>ADM</p> |
| <p><b>200096/6</b></p>  <p>JT.INJ.PEUGEOT PART. 1.8 8V MPI C/ JTAS<br/>ADM</p> |  |  |  |

**385 JUNTAS INJ. ELETR - RENAULT (SIMPLES)**

|  |   |  |   |
|--|---|--|---|
| <p><b>225026/6</b></p>  <p>JTAS.INJ. RENAULT TWINGO SIST. MARELLI<br/>SPI</p> | <p><b>225027/7</b></p>  <p>JTAS.INJ. RENAULT CLIO/19 SIST. MARELLI<br/>SPI</p>           | <p><b>225043/3</b></p>  <p>JTAS.INJ. RENAULT MEGANE 2.0 MPFI</p>                 | <p><b>225051/1</b></p>  <p>JTAS.INJ. RENAULT CLIO/19 RN/RT 1.6 SPI</p>                   |
| <p><b>225052/2</b></p>  <p>JTAS.INJ. RENAULT LAGUNA 1.8 MPFI</p>              | <p><b>225076/6</b></p>  <p>JTAS.INJ. RENAULT RN/RL/RT1.0/CLIO<br/>HATCH 16V 2000 MPI</p> | <p><b>225077/7</b></p>  <p>JTAS.INJ. RENAULT SEDAN CLIO 1.6 2000<br/>16V MPI</p> | <p><b>225078/8</b></p>  <p>JTAS.INJ. RENAULT CLIO HATCH RN/RL/RT<br/>1.0 8V 2000 MPI</p> |

**385 JUNTAS INJ. ELETR. - RENAULT (SIMPLES)**

|   |   |  |  |
|---|---|--|--|
| <p><b>225079/9</b></p> <p>JTAS.INJ. RENAULT RN/RL/RT 1.0/CLIO HATCH 16V 2000 MPI C/COLET.</p> | <p><b>225080/0</b></p> <p>JTAS.INJ. RENAULT SEDAN CLIO 1.6 2000 16V MPI C/COLETOR</p> | <p><b>225081/1</b></p> <p>JTAS.INJ. RENAULT CLIO HATCH RN/RL/RT 1.0 8V 2000 MPI C/COLET.</p> | <p><b>225121/1</b></p> <p>JTAS INJ.MPI 1.6 MOTOR K4M 16 VL SENIC/CLIO/MEGANE/KANGOO 2000/... C/COLETOR</p> |
|---|---|--|--|













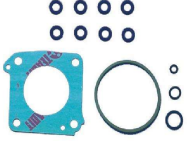

**390 JUNTAS P/ INJ. ELETR. - RENAULT (COMPLETO)**

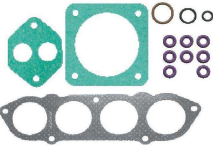
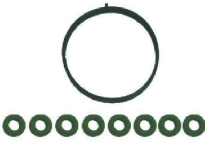
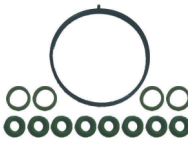
|   |   |  |  |
|---|---|--|--|
| <p><b>200026/6</b></p> <p>JT.INJ. UNO MILLE EP 1.0-SIST.MARELLI G7</p>    | <p><b>200027/7</b></p> <p>JT.INJ. RENAULT 19 / CLIO-SPI</p>             | <p><b>200043/3</b></p> <p>JT.INJ. RENAULT MEGANE 2.0 MPFI</p>            | <p><b>200051/1</b></p> <p>JT.INJ.RENAULT CLIO/19RN/RT1.6 S.BOSCH-SPI</p>                                     |
| <p><b>200052/2</b></p> <p>JT.INJ. RENAULT LAGUNA 1.8 MPFI</p>             | <p><b>200076/6</b></p> <p>JT.INJ.REN. RN/RL/RT1.0/CLIO HAT.16V 2000</p> | <p><b>200077/7</b></p> <p>JT.INJ.RENAULT SEDAN CLIO 1.6 2000 16V MPI</p> | <p><b>200078/8</b></p> <p>JT.INJ.REN.CLIO HAT. RN/RL/RT1.0 8V 2000</p>                                       |
| <p><b>200079/9</b></p> <p>JT.INJ.REN.RN/RL/RT1.0/CLIO 16V 2000 C/COL.</p> | <p><b>200080/0</b></p> <p>JT.INJ.REN.SEDAN CLIO 1.6 2000 16V C/COL.</p> | <p><b>200081/1</b></p> <p>JT.INJ.REN.CLIO HAT. RN/RL/RT1.0 8V 2000/C</p> | <p><b>200121/1</b></p> <p>JT.INJ. RENAULT MPI 1.6 MOTOR K4M 16V SENIC/CLIO/MEGANE/KANGOO 2000/... C/ COL</p> |

**395 JUNTAS INJ. ELETR. - VW (SIMPLES)**

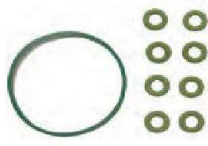
|   |   |   |   |
|---|---|---|---|
| <p><b>225004/4</b></p> <p>JTAS INJ.GOL 1.0 FASE I/III/GOL CLI/SANT.1.8 92/</p>  | <p><b>225008/8</b></p> <p>JTAS INJ.GOL 1000 PLUS AE SIST. FIC VISTEON</p> | <p><b>225011/1</b></p> <p>JTAS.INJ. GOL/PAR/SANT/LOGUS 94/... AE 1.6 E AP 1.8</p> | <p><b>225015/5</b></p> <p>JTAS.INJ. GOL 1.0/1.8/2.0 AP PAR/2.0 GOL GTI/MI</p> |
| <p><b>225020/0</b></p> <p>JTAS.INJ. GOLF GLX/GTI 1.8/2.0 IMPORT.DIGIFANT MI</p> | <p><b>225030/0</b></p> <p>JTAS.INJ. POLO CLASSIC 1.8 M.I</p>              | <p><b>225033/3</b></p> <p>JTAS.INJ. GOLF GL/POINT/CORD.GLX 1.8 SIST.BOSCH SPI</p> | <p><b>225038/8</b></p> <p>JTAS.INJ. GOL 1.6/1.8/2.0 SANT.1.8/2.0 MI</p>       |

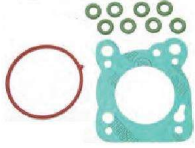
**395 JUNTAS INJ. ELETR. - VW (SIMPLES)**

|  |   |  |  |
|--|---|--|--|
| <p><b>225040/0</b></p>  <p>JTAS.INJ. GOL/PARATI 1000 MI 8V. AT</p>                          | <p><b>225042/2</b></p>  <p>JTAS.INJ. KOMBI 04 CIL. MI MOTRONIC</p>                             | <p><b>225044/4</b></p>  <p>JTAS.INJ. GOLF GLX/GTI/CORD./POINT.1.8/2.0 MI. DIGIFAN C/COL.</p> | <p><b>225046/6</b></p>  <p>JTAS.INJ. VW GOL/PARATI 1000 MI 16V AVS MPFI</p>   |
| <p><b>225053/3</b></p>  <p>JTAS.INJ. GOL 1000 PLUS AE SIST. FIC VISTEON</p>                 | <p><b>225060/0</b></p>  <p>JTAS.INJ. GOLF GL/POINTER/CORD.GLX 1.8 BOSCH MONOTR. C/COL.BORR</p> | <p><b>225075/5</b></p>  <p>JTAS.INJ. GOLF 1.6 NACIONAL MPFI</p>                              | <p><b>225075/6</b></p>  <p>JTAS.INJ. VW GOLF 1.6 NACIONAL MPFI S/ COLETOR</p> |
| <p><b>225082/2</b></p>  <p>JTAS.INJ. GOLF 2.0 MPI 2001 C/ JUNTA DE ADM.</p>                | <p><b>225099/9</b></p>  <p>JTA. INJ. VW GOL IV - 1.0 8V AT TOTALFLEX 06/...</p>               | <p><b>225101/1</b></p>  <p>JTA. INJ. VW FOX 1.0 8V.</p>                                     | <p><b>225102/2</b></p>  <p>JTA. INJ. VW FOX 1.0 8V C/COLETORES</p>           |
| <p><b>225103/3</b></p>  <p>JTA. INJ. VW GOL IV - 1.0 8V AT TOTALFLEX 06/... C/COLETOR</p> | <p><b>225108/8</b></p>  <p>JTAS.INJ. GOLF 1.6 8V -POLO 1.6 8V 2002/...</p>                   | <p><b>225109/9</b></p>  <p>JTAS.INJ. FOX 1.6 8V ANO 2003/... MPI</p>                       | <p><b>225111/1</b></p>  <p>JTAS.INJ. GOL TREND 1.0 8V ANO 2002</p>          |
| <p><b>225112/2</b></p>  <p>JTAS.INJ. GOL POWER/GOL PLUS 1.0 16V ANO 2002</p>              | <p><b>225115/5</b></p>  <p>JT.INJ.VW KOMBI TOTAL FLEX 1.4 8V 2007/</p>                       | <p><b>225116/6</b></p>  <p>JT.INJ.VW KOMBI TOTAL FLEX 1.4 8V 2007/ C/ COLETORES</p>        |  |

**400 JUNTAS P/ INJ. ELETR. - VW (COMPLETO)**

|  |   |  |  |
|--|---|--|--|
| <p><b>200004/4</b></p>  <p>JT.INJ.GOL 1.0 FASE I/II-GOLCLI/SANT1.8 92/...</p> | <p><b>200008/8</b></p>  <p>JT.INJ.GOL MIL PLUS-AE/SIST.FIC VIST.ECC IV</p> | <p><b>200011/1</b></p>  <p>JT.INJ.GOL/PAR/SANT/LOGUS 94/AE1.6/AP 1.8</p> | <p><b>200015/5</b></p>  <p>JT.INJ.GOL1.0/1.8/2.0-AP/PART-2.0/GOLTI/L OGUS/SANT.2.0 MI</p> |
|--|---|--|--|

**400 JUNTAS P/ INJ. ELETR. - VW (COMPLETO)**

|   |  |  |  |
|---|--|--|--|
| <p><b>200020/0</b></p> <p>JT.INJ.GOLF GLX/GTI 1.8/2.0 MI IMP. BOSCH</p>           | <p><b>200030/0</b></p> <p>JT.INJ.POLO CLASSIC 1.8 MI-SIST.MAR. IAW-MPFI</p>  | <p><b>200033/3</b></p> <p>JT.INJ.GOLF GL/POINT./CORD. GLX 1.8 - SIST.BOSCH</p>     | <p><b>200038/8</b></p> <p>JT.INJ.GOL 1.6/1.8/2.0/SANT. 1.8/2.0 MI-S.MAR.</p> |
| <p><b>200040/0</b></p> <p>JT.INJ.GOL/PARATI 1000 MI 8V-AT-S.BOSCH</p>             | <p><b>200042/2</b></p> <p>JT.INJ.KOMBI 04 CIL.MI-S.BOSCH MOTRON.MP 9.0</p>   | <p><b>200044/4</b></p> <p>JT.INJ.GOLF/CORD./POINT. 1.8/2.0 MI-BOSCH C/COL.</p>     | <p><b>200046/6</b></p> <p>JT.INJ.PARATI/GOL 1000 MI 16V. S.MARELLI 1 AVS</p> |
| <p><b>200053/3</b></p> <p>JT.INJ.GOL 1000 PLUS AE-SIST.FIC VIST.EEC IV</p>        | <p><b>200060/0</b></p> <p>JT.INJ.GOLF GL/POINT./CORD.GLX 1.8-C/COLETOR</p>   | <p><b>200075/5</b></p> <p>JT.INJ.GOLF 1.6 NACIONAL MPFI C/ COLETOR</p>             | <p><b>200075/6</b></p> <p>JT.INJ. VW GOLF 1.6 NACIONAL MPFI S/ COLETOR</p>   |
| <p><b>200082/2</b></p> <p>JT.INJ.GOLF 2.0 MPI 2001 C/ JTA ADMISSAO</p>            | <p><b>200099/9</b></p> <p>JT.INJ. VW GOL IV - 1.0 8V AT TOTALFLEX 06/...</p> | <p><b>200101/1</b></p> <p>JT.INJ. VW FOX 1.0 8V</p>                                | <p><b>200102/2</b></p> <p>JT.INJ. VW FOX 1.0 8V C/ COLETORES</p>             |
| <p><b>200103/3</b></p> <p>JT.INJ.VW GOL IV-1.0 8V AT-TOTALFLEX 06/... C/ COL.</p> | <p><b>200108/8</b></p> <p>JT.INJ. GOLF 1.6 8V - POLO 1.6 8V 2002/...</p>     | <p><b>200109/9</b></p> <p>JT.INJ. FOX 1.6 8V ANO 2003/ MPI</p>                     | <p><b>200111/1</b></p> <p>JT.INJ. GOL TREND 1.0 8V ANO 2002</p>              |
| <p><b>200112/2</b></p> <p>JT.INJ.GOL POWER /GOL PLUS 1.0 16V ANO 2002</p>         | <p><b>200115/5</b></p> <p>JT.INJ.VW KOMBI TOTAL FLEX 1.4 8V 2007/...</p>     | <p><b>200116/6</b></p> <p>JT.INJ.VW KOMBI TOTAL FLEX 1.4 8V 2007/ C/ COLETORES</p> |  |



**405 JUNTAS INJ. ELETR. - SUZUKI (SIMPLES)**

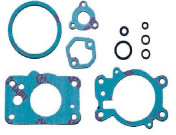

**405 JUNTAS INJ. ELETR. - SUZUKI (SIMPLES)**

|  |   |  |  |
|--|---|--|--|
| <p><b>225057/7</b></p>  <p>JTAS.INJ. SUZUKI SWIFT -SINGLE POINT</p> | <p><b>225058/8</b></p>  <p>JTAS.INJ. SUZUKI VITARA -SINGLE POINT</p> |  |  |
|--|---|--|--|

**410 JUNTAS P/ INJ. ELETR. - SUZUKI (COMPLETO)**

|   |  |  |  |
|---|--|--|--|
| <p><b>200057/7</b></p>  <p>JT.INJ.SUZUKI SWIFT SPI</p> | <p><b>200058/8</b></p>  <p>JT.INJ.SUZUKI VITARA SPI</p> |  |  |
|---|--|--|--|

**415 JUNTAS AVULSAS INJ.ELETR.**

|   |  |  |  |
|---|--|--|--|
| <p><b>300001/C</b></p>  <p>JTA INJ.TBI INTERMEDIARIA TBI MONZA EFI - 2,4MM</p>  | <p><b>300001/D</b></p>  <p>JTA INJ.TBI BASE MONZA EFI (CORBESTO)</p>   | <p><b>300004/A</b></p>  <p>JTA INJ.TBI GOL (LOSANGO FECHADO)</p>  | <p><b>300011/A</b></p>  <p>JTA INJ.TBI BASE GOL (LOSANGO ABERTO)</p>   |
| <p><b>300016/A</b></p>  <p>JTA INJ.TBI QUADRADA CORSA WIND 1.0/1.4/1.6MPFI</p> | <p><b>300038/A</b></p>  <p>JTA INJ.TBI GOL 1.6/1.8/2.0 (038) PHMR</p> | <p><b>320001/B</b></p>  <p>GUARNIÇÃO FILTRO MONZA EFI (NBR )</p> | <p><b>320002/F</b></p>  <p>JUNTA DO FILTRO DE AR TBI FIAT UNO SPI</p> |









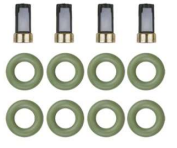
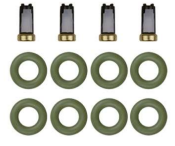

**420 PEÇAS DIVERSAS INJ. ELETR.**

|   |   |  |  |
|---|---|--|--|
| <p><b>207.003/T</b></p>  <p>TRAVA BICO INJETOR INOX MPFI</p> | <p><b>207.029/A</b></p>  <p>PINO TRAVA - FIXAÇÃO CALÇO SPI - 02 PONTAS</p> | <p><b>207.030/A</b></p>  <p>PINO TRAVA - FIXAÇÃO SPI FIAT /VW/ SEAT - 01 PONTA</p> | <p><b>207.9003</b></p>  <p>DISPOSITIVO PARA MONTAR FILTRO MARELLI NOS INJETORES IPE</p> |
| <p><b>320001/3B</b></p>  <p>BUCHA FILTRO MONZA EFI (NBR)</p> | <p><b>320001/3D</b></p>  <p>TAMPAO NBR EFI</p>                             | <p><b>320001/C</b></p>  <p>COTOVELO NBR MONZA EFI</p>                              | <p><b>320001/E</b></p>  <p>AUTODROMO (NBR) EFI</p>                                      |

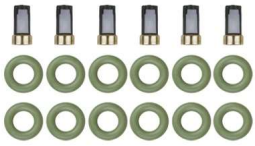























**420 PEÇAS DIVERSAS INJ. ELETR.**

|   |   |  |  |
|---|---|--|--|
| <p><b>320010/2</b></p>  <p>GUARNIÇÃO FILTRO CORSA EFI (NBR)</p>                | <p><b>320010/2A</b></p>  <p>BUCHA CORSA EFI GRANDE (NBR)</p> | <p><b>320041/T</b></p>  <p>TAMPÃO DO ENDURAZETEC NBR</p>   | <p><b>320046/T</b></p>  <p>TAMPÃO DO SISTEMA DE INJEÇÃO</p> |
| <p><b>320047/7</b></p>  <p>JUNTA MODULO VECTRA 2.0 2.2</p>                     | <p><b>320068/AB</b></p>  <p>VEDADOR PALIO FIRE 16V</p>       | <p><b>320107/A</b></p>  <p>JUNTA DO ATUADOR ECO ESPORT</p> | <p><b>320121/A</b></p>  <p>ANEL TRIANGULAR RENAULT</p>      |
| <p><b>320121/D</b></p>  <p>JUNTA DESVIO DE AR QUADRADA INJ. FIAT SILICONE</p> |   |  |  |

**430 KITS P/ BICO INJETOR**

|   |  |  |   |
|---|--|--|---|
| <p><b>208.2003</b></p>  <p>SISTEMA M.MARELLI-SINGLE POINT VW /FORD / FIAT (TELA EM AÇO INOX)</p> <p>(02 FILTROS/02 ANÉIS DE VITON)</p> | <p><b>208.2003 P</b></p>  <p>SISTEMA M.MARELLI-SINGLE POINT VW /FORD / FIAT (TELA EM POLIESTER)</p> <p>(02 FILTROS/02 ANÉIS DE VITON)</p>                               | <p><b>208.2004</b></p>  <p>SISTEMA ROCHESTER - SINGLE POINT GM</p> <p>(02 FILTROS/02 ANÉIS DE VITON)</p>   | <p><b>208.2015</b></p>  <p>SISTEMA BOSCH - MULTI POINT</p> <p>(04 FILTROS/08 ANÉIS DE VITON)</p>                             |
| <p><b>208.2016</b></p>  <p>SISTEMA M.MARELLI - MULTI POINT</p> <p>(04 FILTROS/08 ANÉIS DE VITON)</p>                                   | <p><b>208.2017</b></p>  <p>SISTEMA BOSH - MULTI POINT CELTA/CORSA/VECTRA/S-10 99/...</p> <p>(04 FILTROS/08 ANÉIS DE VITON) BICO INJETOR 25.319.301</p>                  | <p><b>208.2018</b></p>  <p>SISTEMA BOSCH - MULTI POINT ÔMEGA 3.0/4.1 6 CILINDROS</p> <p>(06 FILTROS/12 ANÉIS DE VITON)</p>                                 | <p><b>208.2019</b></p>  <p>SISTEMA M. MARELLI - MULTI POINT ZAFIRA 1.8/PALIO/STILO</p> <p>(04 FILTROS/08 ANÉIS DE VITON)</p> |
| <p><b>208.2022</b></p>  <p>MULTI POINT NISSAN PATHFINDER 06 CILINDROS</p> <p>(06 FILTROS/12 ANÉIS DE VITON)</p>                        | <p><b>208.2023</b></p>  <p>MULTI POINT FIESTA (NACIONAL) /COURIER MOTOR ZETEC1.4 16V</p> <p>(04 FILTROS/04 PONTEIRAS/08 ANÉIS DE VITON) BICO INJETOR: 96MF/9F593/AB</p> | <p><b>208.2024</b></p>  <p>MULTI POINT ESCORT 97/... MOTOR ZETEC 1.816V</p> <p>(04 FILTROS/04 PONTEIRAS/08 ANÉIS DE VITON) BICO INJETOR: 958F/9F593/BB</p> | <p><b>208.2029</b></p>  <p>SISTEMA SIEMENS - MULTI POINT RENAULT 19 / FORD COURIER</p> <p>(04 FILTROS/08 ANÉIS DE VITON)</p> |

**430 KITS P/ BICO INJETOR**

|   |   |   |   |
|---|---|---|---|
| <p><b>208.2064</b></p>  <p>SINGLE POINT FIAT TIPO 1.6 96/... (IMPORT) /REN 19 1.6 96/... REN CLIO1.6 97/...<br/>(02 FILTROS/02 ANÉIS DE VITON / 01 PONTEIRA)<br/>BICO INJETOR: 0.280.150.698</p> | <p><b>208.2306</b></p>  <p>SISTEMA DELPHI - MULTI POINT<br/>CORSA/MERIVA/MONTANA 1.4/1.8FLEX/<br/>CELTA<br/>PRISMA 1.4 FLEX/CORSA/ CELTA 1.0 FLEX - (04<br/>FILTROS/08 ANÉIS DE VITON)</p>                   | <p><b>208.2308</b></p>  <p>SINGLE POINT GOLF1.8 96/...TIPO 1.6<br/>(NACIONAL)<br/>(01FILTRO/01 PONTEIRA/02 ANÉIS DE VITON) BICO<br/>INJETOR:0.280.150.071</p>                                 | <p><b>208.2309</b></p>  <p>KIT P/ BICO INJETOR HONDA CIVIC 02/...<br/>(04 FILTROS/08 ANÉIS DE VITON)</p>   |
| <p><b>208.2312</b></p>  <p>KIT P/ BICO INJETOR SISTEMA DENSO<br/>TOYOTA<br/>(04 FILTROS/04 ANÉIS DE VITON)</p>   | <p><b>208.2313</b></p>  <p>KIT P/ BICO INJETOR SISTEMA DENSO<br/>TOYOTA/COROLLA 1.8 95/02<br/>(04 FILTROS/04 ANÉIS/08 VEDAÇÕES) BICO<br/>INJETOR Nº 232501616</p>  | <p><b>208.2314</b></p>  <p>KIT P/ BICO INJETOR SISTEMA M.MARELLI<br/>FOX/GOL POWER<br/>(4 FILTROS/8 ANÉIS DE VITON/4 GUARDA-PÓS BICO<br/>INJ.KIT COMP.) BICO:IWP170/IWP 176</p>               | <p><b>208.2316</b></p>  <p>KIT P/ BICO INJETOR MEGANE/SCENIC 2.0<br/>16V/CLIO/ LAGUNA 1.6/2.0 16V<br/>(04 FILTROS/ 08 ANÉIS) BICOS : H028797/H132254</p>   |
| <p><b>208.2317</b></p>  <p>KIT P/ BICO INJETOR NISSAN / BICO :<br/>FBY2850 RENAULT FLUENCE 2.0 / BICO :<br/>H106845<br/>(04 FILTROS/ 08 ANÉIS)</p>  | <p><b>208.2318</b></p>  <p>KIT P/ BICO INJETOR NISSAN / BICO :<br/>FBY2850 RENAULT FLUENCE 2.0 / BICO :<br/>H106845<br/>(04 FILTROS/08 ANÉIS/04 PONTEIRAS)</p>   | <p><b>208.2319</b></p>  <p>KIT P/ BICO INJETOR TOYOTA HILUX<br/>GASOLINA - BICO DENSO VINHO<br/>(04 FILTROS, 04 ANÉIS 04 PONTEIRAS) INJETOR<br/>23250-35040</p>                              | <p><b>208.2321</b></p>  <p>KIT P/ BICO INJETOR TOYOTA COROLLA 1.8<br/>16 V 02/07 BICO DENSO VERDE<br/>(04 FILTROS, 04 ANÉIS E 08 VEDAÇÕES) INJETOR<br/>23250-22040</p>                                    |
| <p><b>208.2322</b></p>  <p>KIT P/ BICO INJETOR HONDA CIVIC/FIT 01/05<br/>(04 FILTROS, 04 PONTEIRAS E 08 ANÉIS) INJETOR<br/>IPH21/16450PLC003</p>   | <p><b>208.2323</b></p>  <p>KIT P/ BICO INJETOR SISTEMA MAGNETI<br/>MARELLI - INJETORES IPE<br/>(04 FILTROS E 08 ANÉIS)</p>   | <p><b>208.2324</b></p>  <p>KIT P/ BICO INJETOR FIESTA 95<br/>IMPORTADO<br/>(01 FILTRO E 02 ANÉIS)</p>   | <p><b>208.2325</b></p>  <p>KIT P/ BICO INJETOR SUBARU<br/>(04 FILTROS E 08 ANÉIS)</p>  |
| <p><b>208.2326</b></p>  <p>KIT P/ BICO INJETOR PEUGEOT<br/>(04 FILTROS E 08 ANÉIS)</p>   | <p><b>208.2327</b></p>  <p>KIT P/ BICO INJETOR NEW CIVIC 1.8 16 V<br/>FLEX / FIT 1.4/1.5 FLEX / CITY 1.5 FLEX<br/>(04 FILTROS/08 ANÉIS/04 PONTEIRAS/04<br/>ARRUELAS) - BICOS: YD073SD/YD024SD/YD0 62SD</p> | <p><b>208.2328</b></p>  <p>KIT P/ BICO INJETOR TOYOTA MOTOR V6 -<br/>HILUX SW4/ CAMRY - INJETOR DENSO<br/>MARRON<br/>(06 FILTROS, 06 PONTEIRAS, 06 ANÉIS E 12<br/>VEDAÇÕES)</p>             | <p><b>208.2330</b></p>  <p>KIT P/ BICO INJETOR - SISTEMA BOSCH<br/>MULTI POINT<br/>(KIT COM 04 FILTROS, 08 ANÉIS, 04 PONTEIRAS)</p>  |
| <p><b>208.2338</b></p>  <p>KIT P/ BICO INJETOR BLAZER/S10 06<br/>CILINDROS<br/>(KIT COM 06 FILTROS, 12 ANÉIS E 06 ARRUELAS)</p>  | <p><b>208.2339</b></p>  <p>KIT P/ BICO INJETOR - PARTIDA À FRIO<br/>NEW CITY/NEW FIT BICO YG21 - KIT<br/>COMPLETO<br/>(KIT COM 05 FILTROS/10 ANÉIS/04 PONTEIRAS)</p>                                       | <p><b>208.2342</b></p>  <p>KIT P/ BICO INJETOR S10 2.5 FLEX/CAPTIVA<br/>2.4 4CC / CAMARO 3.6 6CC<br/>(KIT COM 1 FILTRO/1 CAP. BORR./ 2 ANÉIS<br/>TEFLON/2 DISCOS APOIO/1 ANEL DE VITON)</p> | <p><b>208.2343</b></p>  <p>KIT P/ BICO INJETOR AUDI A3/ AUDI<br/>SPORTBACK/AUDI TSFI /RANGE ROVER<br/>EVOQUE 2.0<br/>(KIT COM 01 FILTRO/02 DISCOS DE TEFLON/ 01<br/>ANEL DE TEFLON/01 ANEL DE VITON)</p> |













**430 KITS P/ BICO INJETOR**

|  |   |   |  |
|--|---|---|--|
| <p><b>208.2344</b></p>  <p>KIT P/ BICO INJ. AUDI/PASSAT/JETTA 2.0<br/>TSFI /TIGUAN/GOLF/MINI<br/>/PEUGEOT/CITROENTHP<br/>(01 ANEL DE VITON/ 01ANEL DE TEFLON/01 DISCO<br/>DE TEFLON/ 01 SUPORTE PLÁSTICO)</p> | <p><b>208.2345</b></p>  <p>KIT P/ BICO INJETOR CAPTIVA 3.0 LT/LTZ<br/>V6/CAMARO1LS/2LS 3,6L 6CC<br/>(01 FILTRO/01 ANEL DE VITON/01 CAP BORR./ 02<br/>ANÉIS DE TEFLON/02DISCOS DE TEFLON)</p> | <p><b>208.2360</b></p>  <p>KIT P/ BICO INJ. AUDI/PASSAT/JETTA 2.0<br/>TSFI TIGUAN/GOLF/MINI /PEUGEOT<br/>CITROENTHP<br/>(1 ANEL VITON,1 ANEL TEFLON, 1 DISCO DE<br/>TEFLON, 1 SUPORTE PLÁSTICO,01 FILTRO)</p> |  |
|--|---|---|--|

**432 FILTRO P/ BICO INJETOR**

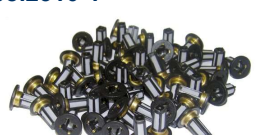



|   |  |   |  |
|---|--|---|--|
| <p><b>208.2013</b></p>  <p>FILTROS BICO INJ. SISTEMA<br/>M.MARELLI-SINGLE POINT VW/FORD/FIAT<br/>(02 FILTROS) (TELA EM AÇO INOX)</p> | <p><b>208.2013 P</b></p>  <p>FILTROS BICO INJ. SISTEMA<br/>M.MARELLI-SINGLE POINT VW/FORD/FIAT<br/>(02 FILTROS) (TELA EM POLIESTER)</p> | <p><b>208.2014</b></p>  <p>FILTROS BICO INJ. SISTEMA<br/>ROCHESTER-SINGLE POINT GM<br/>(02 FILTROS)</p> | <p><b>208.2025</b></p>  <p>FILTROS BICO INJ. SISTEMA BOSCH-MULTI<br/>POINT<br/>(04 FILTROS)</p> |
| <p><b>208.2026</b></p>  <p>FILTROS BICO INJ. SISTEMA M.MARELLI -<br/>MULTI POINT<br/>(04 FILTROS)</p>                               |  |   |  |

**433 FILTRO, ANEL E ARRUELA \*EMBALAGEM 100UN PREÇO UN\***





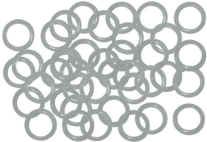











|  |   |   |  |
|--|---|---|--|
| <p><b>208.2025-1</b></p>  <p>FILTROS BICO INJ. SISTEMA BOSCH-MULTI<br/>POINT<br/>(EMBALAGEM 100 UN PREÇO UN)</p>    | <p><b>208.2026-1</b></p>  <p>FILTROS BICO INJ. SISTEMA<br/>M.MARELLI-MULTI POINT<br/>(EMBALAGEM 100 UN PREÇO UN)</p> | <p><b>208.2033</b></p>  <p>ANEL DE VITON P/ BICO INJETOR SISTEMA<br/>BOSCH/M.MARELLI<br/>(EMBALAGEM 100 UN PREÇO UN)</p>  | <p><b>208.2043</b></p>  <p>ANEL DE VITON CELTA/CORSA/VECTRA/S<br/>10<br/>(EMBALAGEM 100 UN PREÇO UN)</p>  |
| <p><b>208.2044</b></p>  <p>ANEL DE VITON P/ BICO INJETOR<br/>ZAFIRA/STILO/PALIO<br/>(EMBALAGEM 100 UN PREÇO UN)</p> | <p><b>208.2048</b></p>  <p>ANEL DE VITON PARA BICOS IMPORTADOS<br/>(EMBALAGEM 100 UN PREÇO UN)</p>                   | <p><b>208.2049</b></p>  <p>ANEL DE VITON P/ BICO INJETOR GOL<br/>POWER/FOX 1.0 8 VÁLVULAS<br/>(EMBALAGEM 100 UN PREÇO UN)</p>                                     | <p><b>208.2307-1</b></p>  <p>FILTROS BICO INJ. SISTEMA DELPHI -<br/>MULTI POINT<br/>(EMBALAGEM 100 UN PREÇO UN)</p>                                 |
| <p><b>208.2310-1</b></p>  <p>FILTROS BICO INJ. HONDA CIVIC 02/...<br/>(EMBALAGEM 100 UN PREÇO UN)</p>               | <p><b>208.2312-1</b></p>  <p>FILTROS BICO INJ. SISTEMA DENSO -<br/>TOYOTA<br/>(VENDA MIN. 100 PÇS / PREÇO UNIT)</p>  | <p><b>208.2316-1</b></p>  <p>FILTROS BICO INJ. MEGANE/SCENIC 2.0<br/>16V/CLIO/ LAGUNA 1.6/2.0 16V<br/>(EMBALAGEM 100 UN PREÇO UN) BICOS :<br/>H028797/H132254</p> | <p><b>208.2317-1</b></p>  <p>FILTROS BICO INJ. NISSAN / BICO : FBY2850<br/>RENAULT FLUENCE 2.0 / BICO : H106845<br/>(EMBALAGEM 100 UN PREÇO UN)</p> |

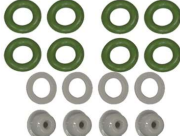

**433 FILTRO, ANEL E ARRUELA \*EMBALAGEM 100UN PREÇO UN\***

|  |  |  |  |
|--|--|--|--|
| <p><b>208.2322-1</b></p>  <p>FILTROS BICO INJ. HONDA CIVIC/FIT 01/05</p> <p>(EMBALAGEM 100 UN PREÇO UN)</p>                         | <p><b>208.2360-1</b></p>  <p>FILTROS BICO INJ. AUDI/PASSAT/JETTA 2.0 TSFI TIGUAN/GOLF/MINI/PGEOT CITROEN THP</p> <p>(EMB. 100 PCS) INJ 0.261.500.073/ 0.261.500.076/ 0.261.500.244/ 0.261.500.162</p> | <p><b>208.2361</b></p>  <p>ANÉIS DE VITON (INJEÇÃO DIRETA) AUDI/PASSAT/JETTA – TSFI PEUGEOT/CITROEN – THP</p> <p>(EMB. 100 PCS) INJ. 0.261.500.073/0.261.500.076/0.261.500.244/0.261/500.1</p> | <p><b>208.2362</b></p>  <p>ANÉIS DE VITON (INJEÇÃO DIRETA) CAPTIVA 3.0 LT/LTZ V6/ CAMARO V6</p> <p>(EMBALAGEM 100 UN PREÇO UN) Nº ORIG. INJETORES 12642021 / 12629927</p> |
| <p><b>208.2367-1</b></p>  <p>ARRUELAS PLÁSTICAS SUPERIORES TRAVA MENOR - BICOS BOSCH E DENSO</p> <p>(EMBALAGEM 100 UN PREÇO UN)</p> | <p><b>208.5339</b></p>  <p>ANEL DE VITON AZUL PARTIDA A FRIO HONDA</p> <p>(EMBALAGEM 100 UN PREÇO UN)</p>   |  |  |

**435 COMPONENTES P/ BICO INJETOR**

|  |  |   |   |
|--|--|---|---|
| <p><b>208.1714</b></p>  <p>GUARDA-PÓ PARA BICO INJETOR M.MARELLI VW</p> <p>(04 UNIDADES)</p>   | <p><b>208.2006</b></p>  <p>PONTAS P/ BICO INJETOR SISTEMA BOSCH-MULTI POINT</p> <p>(04 PONTEIRAS/04 ARRUELAS)</p>                                      | <p><b>208.2007</b></p>  <p>PONTAS P/ BICO INJETOR SISTEMA MAGNETI MARELLI-MULTI POINT</p> <p>(04 PONTEIRAS/04 ARRUELAS) BICO INJETOR:214.303.000/IW330</p> | <p><b>208.2008</b></p>  <p>PONTAS P/ BICO INJETOR SISTEMA MAGNETI MARELLI-MULTI POINT</p> <p>(04 PONTEIRAS/04ARRUELAS)</p>  |
| <p><b>208.2011</b></p>  <p>PONTAS P/ BICO INJETOR SISTEMA BOSCH-MULTI POINT</p> <p>(04 PONTEIRAS) BICO INJETOR:25.319.300</p>                 | <p><b>208.2012</b></p>  <p>PONTAS P/ BICO INJETOR SISTEMA DELPHI-MULTI POINT</p> <p>(04 PONTEIRAS) BICOS INJETORES: 0.280.155.929 / 0.280.156.095</p> | <p><b>208.2027</b></p>  <p>KIT DE BUCHAS FIXAÇÃO BICO INJ. AO CABEÇOTE GM-ÔMEGA 4.1/ 06 CC SIST.MULTI POINT</p>   | <p><b>208.2028</b></p>  <p>BUCHAS DE FIXAÇÃO DO BICO INJETOR AO CABEÇOTE VW SISTEMA MULTI POINT</p> <p>(04 PONTEIRAS)</p>  |
| <p><b>208.2034</b></p>  <p>KIT DE ANÉIS DE VITON P/BICO INJETOR SISTEMA MARELLI/ROCHESTER- SINGLE POINT</p> <p>(02 ANÉIS)</p>                 | <p><b>208.2035</b></p>  <p>PONTAS P/ BICO INJETOR SISTEMA BOSCH-MULTI POINT</p> <p>(04 PONTEIRAS) BICOS INJETORES: 0.280.155.929 / 0.280.156.095</p>  | <p><b>208.2036</b></p>  <p>PONTAS P/ BICO INJETOR SISTEMA BOSCH-MULTI POINT</p> <p>(04 PONTEIRAS/04 ARRUELAS/08 ANÉIS DE VITON)</p>                       | <p><b>208.2037</b></p>  <p>PONTAS P/ BICO INJETOR SISTEMA MAGNETI MARELLI-MULTI POINT</p> <p>(04 PONTEIRAS/04 ARRUELAS/08 ANÉIS DEVITON) BICO INJETOR: 214.303.000/IW330</p> |
| <p><b>208.2038</b></p>  <p>PONTAS P/ BICO INJETOR SISTEMA MAGNETI MARELLI-MULTI POINT</p> <p>(04 PONTEIRAS/04 ARRUELAS/08 ANÉIS DE VITON)</p> | <p><b>208.2040</b></p>  <p>BUCHAS DE FIXAÇÃO DO BICO INJETOR AO CABEÇOTE VW-GOLF SISTEMA MULTI POINT</p> <p>(04 PONTEIRAS)</p>                        | <p><b>208.2041</b></p>  <p>PONTAS P/ BICO INJETOR SISTEMA DELPHI-MULTI POINT</p> <p>(04 PONTEIRAS/08 ANÉIS DE VITON) BICO INJETOR: 25.319.300</p>         | <p><b>208.2042</b></p>  <p>PONTAS P/ BICO INJETOR SISTEMA BOSCH-MULTI POINT</p> <p>(04 PONTEIRAS/ 08 ANÉIS DE VITON) BICOS INJETORES:0.280.155.929 / 0.280.156.095</p>       |





**435 COMPONENTES P/ BICO INJETOR**

|   |   |   |   |
|---|---|---|---|
| <p><b>208.2045</b></p> <p>KIT DE ANÉIS DE VITON P/ BICO INJETOR CELTA/CORSA/VECTRA/S 10</p> <p>(08 ANÉIS)</p>   | <p><b>208.2046</b></p> <p>KIT DE ANÉIS DE VITON SISTEMA M. MARELLI/ROCHESTER/BOSCH</p> <p>(08 ANÉIS)</p>  | <p><b>208.2047</b></p> <p>KIT DE ANÉIS DE VITON P/ BICO INJETOR ZAFIRA/STILO/PALIO</p> <p>(08 ANÉIS)</p>                                | <p><b>208.2061</b></p> <p>PONTAS P/ BICO INJETOR TOYOTA</p> <p>(04 PONTEIRAS)</p>   |
| <p><b>208.2329</b></p> <p>PONTAS P/ BICO INJETOR NISSAN – BICO FBY2850 RENAULT FLUENCE – BICO H106845</p> <p>(04 PONTEIRAS)</p>   | <p><b>208.2335</b></p> <p>KIT DE ANÉIS PARA BICO INJETOR SUZUKI VITARA/SIDEKICK/GRAN VITARA MITSUBISHI LANCER/ECLIPSE - (KIT COM 04 ANÉIS, 08 VEDAÇÕES)</p> | <p><b>208.2336</b></p> <p>KIT DE ANÉIS PARA BICO INJETOR COROLLA 1.6 1.8/CAMRY/HILUX 2.2 2.7</p> <p>(KIT COM 04 ANÉIS, 08 VEDAÇÕES)</p> | <p><b>208.2337</b></p> <p>KIT DE ANÉIS PARA BICO INJETOR HONDA 1.6 16 V GASOLINA</p> <p>(KIT COM 04 ANÉIS, 08 VEDAÇÕES)</p> |
| <p><b>208.2346</b></p> <p>CAPAS DE BORR. P/ INJ. S10 2.5 FLEX/CAPTIVA 2.4 4 CC/ 3.0 6CC/ CAMARO 3.6 6 CC</p> <p>(EMBALAGEM COM 10 PEÇAS) Nº ORIG.INJETORES:12633784/0.261.500.106</p> | <p><b>208.2348</b></p> <p>PONTAS P/ BICO INJETOR HONDA CIVIC/FIT</p> <p>(KIT COM 04 PONTEIRAS) NºORIG.INJETOR IPH21/16450PL0003</p>                         | <p><b>208.2349</b></p> <p>PONTAS P/ BICO INJETOR HONDA NEW CIVIC/FIT/CITY</p> <p>(KIT COM 04 PONTEIRAS E 04 ARRUELAS)</p>               | <p><b>208.2365</b></p> <p>PONTAS P/BICO INJETOR - SISTEMA DENSO</p> <p>(04 PONTEIRAS)</p>                                   |
| <p><b>208.2367</b></p> <p>ARRUELAS PLÁSTICAS SUPERIORES TRAVA MENOR - BICOS BOSCH E DENSO</p> <p>(KIT COM 04 ARRUELAS)</p>  | <p><b>208.5004</b></p> <p>KIT DE ANÉIS DE VITON P/ BICO INJETOR IWP170/IWP176 GOL POWER/FOX</p> <p>(08 ANÉIS)</p>   | <p><b>208.5007</b></p> <p>GUARDA PÓ PARA O BICO INJETOR BOSCH</p> <p>(04 UNIDADES)</p>  | <p><b>208.5008</b></p> <p>BORRACHA DE VEDAÇÃO DO BICO INJETOR DENSO - PARTE INFERIOR</p> <p>(04 UNIDADES)</p>               |
| <p><b>208.5009</b></p> <p>BORRACHA DE VEDAÇÃO DO BICO INJETOR DENSO - PARTE SUPERIOR</p> <p>(04 UNIDADES)</p>   | <p><b>208.5340</b></p> <p>KIT VEDAÇÃO P/ BICO INJETOR GOLF/CORDOBA 2.0 MI</p> <p>(04 PONTEIRAS)</p>   | <p><b>208.5342</b></p> <p>BORRACHA VEDAÇÃO BICO INJETOR - RENAULT MEGANE</p> <p>(04 PONTEIRAS)</p>                                      |   |

**440 FILTRO DE COMBUSTIVEL**

|  |  |  |  |
|--|--|--|--|
| <p><b>110000</b></p> <p>FILT.COMB. GOL 1.6/1.8 MI/GOL 1.0/16V./GOL TURBO/GOL 2.0 16V</p> | <p><b>110010</b></p> <p>FILT.COMB. ESCORT 1.6/ 1.8-16V ZETEC ROCAN</p> | <p><b>110020</b></p> <p>FILT.COMB. GOL 1000 AE/GOL PLUS/GOL 1.6/1.8/2.0 AE</p> | <p><b>110030</b></p> <p>FILT.COMB. VECTRA GSI 2.0 16V-ASTRA 1.4I /1.6I /1.8I</p> |
|--|--|--|--|

**440 FILTRO DE COMBUSTIVEL**

|  |  |  |   |
|--|--|--|---|
| <p><b>110040</b></p>  <p>FILT.COMB. CORSA 1.0/1.4/1.6-16V/CORSA 1.0 8V/1.8 8V</p> | <p><b>110050</b></p>  <p>FILT.COMB. MONZA/IPANEMA 1.6/1.8/2.0 EFI</p>                   | <p><b>110060</b></p>  <p>FILT.COMB. UNO FIRE 1.0/PALIO/WEEKEND/STRADA /SIENA FIRE 1.0 8V</p> | <p><b>110065</b></p>  <p>FILT.COMB. GOL 2.0 8V/GOL GTI 2.0/GOLF 1.6/1.8/2.0</p>        |
| <p><b>110070</b></p>  <p>FILT.COMB. PALIO 1.0 8V/PALIO/WEEKEND/SIENA</p>          | <p><b>110075</b></p>  <p>FILT.COMB. AUDI A3 1.6/A3 1.8 20V/TT 1.8 20V/VW BEETLE 2.0</p> | <p><b>110080</b></p>  <p>FILT.COMB. UNIV-GAS/ALC.(SACO PLAST.)<br/><b>GRANDE</b></p>         | <p><b>110090</b></p>  <p>FILT.COMB. UNIV-GASOLINA (SACO PLAST.)<br/><b>PEQUENO</b></p> |
| <p><b>110100</b></p>  <p>FILT.COMB. UNIV-PART.RÁP./MOTOS(SACO PLAST.)</p>         | <p><b>110110</b></p>  <p>FILT.COMB. UNO 1.6/UNO MILLE/FIOR.MPI/TEMPRA 16V</p>           | <p><b>110120</b></p>  <p>FILT.COMB. FOX 1.0 TOTALFLEX</p>                                    | <p><b>110130</b></p>  <p>FILT.COMB. ECOSPORT 1.0/1.6/2.0 /NOVO FIESTA 02</p>           |

**445 GUARNIÇÕES**

|  |  |   |  |
|--|--|---|--|
| <p><b>211.2067</b></p>  <p>GUARN. FLANGE MÓD. COMB. FIAT PALIO/UNO/STRADA/ WEEKEND/SIENA<br/>N° ORIG. 7.527.545</p>                 | <p><b>211.2068</b></p>  <p>GUARN. FLANGE MÓD. COMB. CORSA/CLASSIC 94/99 / VECTRA 97/05<br/>N° ORIG. 90.411.085</p>                                  | <p><b>211.2069</b></p>  <p>GUARN. FLANGE MÓD. COMB. GOL MOD. 96/SANTANA/VERSAILLES /F1000 / R19 KOMBI FLEX<br/>N° ORIG. 377.919.133/325.998.053</p> | <p><b>211.2070</b></p>  <p>GUARN. FLANGE MÓD. COMB. GOL/LOGUS/ ESCORT/PAMPA/MAREA99/ CIVIC 1.7 01/07 (GAS.)<br/>FIT 1.4/1.5 03/09 (GAS.) - N° ORIG. 547.919.131/547.988.055/17574-S1A-E01</p> |
| <p><b>211.2071</b></p>  <p>GUARN. FLANGE MÓD. COMB. BLAZER/S10 FLEX 07/.../ BLAZER/S10 2.2/4.3 V6 96/00<br/>N° ORIG. 25.027.014</p> | <p><b>211.2072</b></p>  <p>GUARN. FL MÓD. COMB. ECOSPORT 03/ KA 08/ FIESTA 96/06 /FOCUS 00/NEW FIESTA 12/ COURIER 97/00 - N° ORIG. 98AP/9276/AB</p> | <p><b>211.2073</b></p>  <p>GUARN. FLANGE MÓD. COMB. NISSAN LIVINA/GRAND LIVINA / TIIDA/NOVO SENTRA<br/>N° ORIG. 17342AZ60A</p>                      | <p><b>211.2074</b></p>  <p>GUARN. FLANGE MÓD. COMB. OMEGA 2.0/2.2/3.0/4.11 TODOS GASOLINA 92/...<br/>N° ORIG. 90.322.794</p>  |
| <p><b>211.2075</b></p>  <p>GUARN. FLANGE MÓD. COMB. ASTRA 99/... (GAS.) / MERIVA/ZAFIRA 1.8/2.0 01/...<br/>N° ORIG. 90.572.097</p>  | <p><b>211.2076</b></p>  <p>GUARN. FLANGE MÓD. COMB. PRISMA 06/14 / AGILE 10/14 / CELTA 01/14 CLASSIC 99/14 / CORSA 99/14 - N° ORIG. 93.280.050</p>  | <p><b>211.2077</b></p>  <p>GUARN. FLANGE MÓD. COMB. KADETT /IPANEMA 97/...<br/>N° ORIG. 92.211.923</p>  | <p><b>211.2078</b></p>  <p>GUARN. FLANGE MÓD. COMB. PEUGEOT 206 (TODOS) / PARTNER /406 / 306 98/01 1.8 16 V<br/>N° ORIG. 15.31.24</p>   |

**445 GUARNIÇÕES**

|   |   |   |  |
|---|---|---|--|
| <p><b>211.2079</b></p> <p>GUARN. FLANGE MÓD. COMB. RENAULT CLIO II/III/LAGUNA/ LOGAN 07/.../ SANDERO 08/... /MEGANE II/SCENIC II/ TWINGO/ KANGOO 99/...</p>                             | <p><b>211.2080</b></p> <p>GUARN. FLANGE MÓD. COMB. ESCORT 88/92/F-1000 92/98/ HOBBY 93/96</p> <p>Nº ORIG. 542.919.131</p> | <p><b>211.2081</b></p> <p>GUARN. FLANGE MÓD. COMB. RANGER 97/...</p> <p>Nº ORIG. F87A/9417/AA</p>   | <p><b>211.2082</b></p> <p>GUARN. FLANGE MÓD. COMB. F-250 / F-350 98/...</p> <p>Nº ORIG. F75Z/9A307/AA</p>  |
| <p><b>211.2083</b></p> <p>GUARN. BOMBA DE COMB. FIAT 500 10/... /BRAVO II/... / DOBLO 02/... LINEA 09/... PUNTO 08/... / STILO 03/11 ALPHA ROMEO 147 / 156 SW - Nº ORIG. 46.523.406</p> | <p><b>211.2084</b></p> <p>GUARNIÇÃO DA FLANGE TUBULAR FIAT - MOTOR 1.5 (10 FUROS)</p>                                     | <p><b>211.2085</b></p> <p>GUARN. FLANGE MÓD. COMB. VECTRA 94/96 / ASTRA 95/96</p> <p>Nº ORIG. 90.232.009</p>  | <p><b>211.2086</b></p> <p>GUARNIÇÃO DA BOIA TUBULAR FIAT (8 FUROS)</p>   |
| <p><b>211.2087</b></p> <p>GUARN. FLANGE MÓD. COMB. PEUGEOT 306/CITROEN XANTIA</p> <p>Nº ORIG. 15.28.23</p>  | <p><b>211.2088</b></p> <p>GUARN. FLANGE MÓD. COMB. PEUGEOT 207/307/ CITROEN C3/C4</p> <p>Nº ORIG. 15.31.41</p>            | <p><b>211.2089</b></p> <p>GUARN. FLANGE MÓD. COMB. CORSA 1.4/1.8 FLEX 10/11 / MERIVA 03/12 / MONTANA 04/11</p> <p>Nº ORIG. 93.360.898</p>   | <p><b>211.2090</b></p> <p>JUNTA VED. MED. NÍVEL GOL/VOYAGE/PARATI/ SAVEIRO 83/96 (S/I.E)</p> <p>SANTANA/ QUANTUM (TODOS S/I.E.) - Nº ORIG. ZBA.919131/AA</p> |
| <p><b>211.2091</b></p> <p>JUNTA VED. MED. NÍVEL IPANEMA/KADETT 94/98 (EFI/MPFI)</p> <p>OPALA 90/92 C/D20 93/96 SILVERADO 97/01 - Nº ORIG. 93.205.389</p>                                | <p><b>211.2092</b></p> <p>GUARNIÇÃO DA BÓIA TUBULAR ELBA/FIORINO/PRÊMIO/UNO .../88</p>                                    | <p><b>211.2093</b></p> <p>GUARN. FLANGE MÓD. COMB. CIVIC 1.8 07/... (GAS/FLEX)</p> <p>Nº ORIG. 170.52</p>   | <p><b>211.2094</b></p> <p>JUNTA DO TANQUE DE COMBUSTÍVEL AO TUBO ESCORT 86/... HOBBY 93/96</p>   |
| <p><b>211.2095</b></p> <p>JUNTA DO TANQUE DE COMBUSTÍVEL AO TUBO ESCORT 93/... (TODOS) / F1000 92/98</p>  | <p><b>211.2096</b></p> <p>JUNTA DE VEDAÇÃO DO MEDIDOR DE NÍVEL ELBA/FIORINO/PRÊMIO/UNO .../88</p>                         | <p><b>211.2099</b></p> <p>GUARN. FLANGE MÓD. COMB. COBALT 12/... /ONIX 13/... / PRISMA 13/... /SPIN 13/...</p> <p>Nº ORIG. 52.029.978 DIÂMETRO INTERNO: 144,00 MM / SECCÃO: 5,30 MM</p> | <p><b>211.5001</b></p> <p>GUARNIÇÃO DO FILTRO DE AR FIAT UNO (TODOS-MONOPONTO)</p>   |
| <p><b>211.5002</b></p> <p>GUARNIÇÃO DO FILTRO DE AR CORSA (TODOS-MONOPONTO)</p>   | <p><b>211.5003</b></p> <p>GUARNIÇÃO DO FILTRO DE AR MONZA (TODOS-MONOPONTO)</p>   | <p><b>211.5010</b></p> <p>VEDADOR DO GARGALO TANQUE COMB. CORSA 1.0/1.8 02/... FLEX/GASOLINA</p> <p>Nº ORIG. 24.426.086</p>   | <p><b>211.5011</b></p> <p>VEDADOR DO GARGALO TANQUE COMB. CORSA 94/01 / CELTA 00/14 / CLASSIC 94/14</p> <p>PRISMA 06/13 - Nº ORIG. 90.411.904</p>            |

**445 GUARNIÇÕES**

|   |   |   |  |
|---|---|---|--|
| <p><b>211.5012</b></p>  <p>VEDADOR DO GARGALO TANQUE COMB. MERIVA 03/12 / MONTANA 04/11<br/>N° ORIG. 93.340.653</p>                                    | <p><b>211.5013</b></p>  <p>GUARN. FLANGE MÓD. COMB. HB20 / HB20 S 1.0/1.6 TUCSON 13/... (FLEX)<br/>N° ORIG. 311152P000</p>   | <p><b>211.5014</b></p>  <p>GUARN. FLANGE MÓD. COMB. TOYOTA HILUX 04/...<br/>N° ORIG. 77169-0K010</p>                      | <p><b>211.5015</b></p>  <p>GUARN. FLANGE MÓD. COMB. TOYOTA ETIOS 12/...<br/>N° ORIG. 77169-0D060</p>      |
| <p><b>211.5016</b></p>  <p>GUARN. FLANGE MÓD. COMB. TOYOTA COROLLA 08/14<br/>N° ORIG. 77169-02080</p>  | <p><b>211.5017</b></p>  <p>GUARN. FLANGE MÓD. COMB. CAMINHÕES VW .../02 / MBB .../00 / AGRALE .../05</p>   | <p><b>211.5018</b></p>  <p>GUARN. BOMBA DE COMB. CITROEN C3/C4/AIR CROSS 13/...<br/>N° ORIG. 153153</p>                   | <p><b>211.5019</b></p>  <p>GUARN. BOMBA DE COMB. VW JETTA 10/15<br/>N° ORIG. 150919133B</p>               |
| <p><b>211.5020</b></p>  <p>GUARN. BOMBA DE COMB. CRUZE 12/14 / OMEGA 99/09 / TRACKER 14/...<br/>CAPTIVA 08/14 / SONIC 12/15 - N° ORIG. 22.682.111</p> | <p><b>211.5021</b></p>  <p>GUARN. BOMBA DE COMB. HYUNDAI TUCSON<br/>N° ORIG. 311152E300</p>   | <p><b>211.5022</b></p>  <p>GUARN. BOMBA DE COMB. KIA SOUL FLEX<br/>N° ORIG. 31110-1Y700</p>                              | <p><b>211.5023</b></p>  <p>GUARN. BOMBA DE COMB. S10/BLAZER 2.8 DIESEL 03/10<br/>N° ORIG. 93.340.908</p> |
| <p><b>211.5024</b></p>  <p>GUARN. BOMBA DE COMB. LOGAN/SANDERO 13/...<br/>N° ORIG. 93.340.908</p>  | <p><b>211.5025</b></p>  <p>GUARN. BOMBA DE COMB. ÔNIX 13/17 / PRISMA 13/17 / SPIN 13/18 / COBALT 14/18<br/>DIÁ. INT.: 140,2 MM /SECCÃO 5,40 MM N° ORIG. 52.071.053</p> | <p><b>211.5026</b></p>  <p>GUARN. BOMBA DE COMB. S10 12/18/TRAILBLAZER 13/18 2.5/2.8 DIESEL<br/>N° ORIG. 94.726.496</p> |  |

**450 MANGUEIRAS DIVERSAS**

















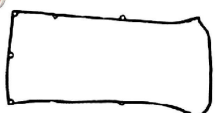



|  |   |   |  |
|--|---|---|--|
| <p><b>216.1015</b></p>  <p>MANGUEIRA LEITOSA 1.2X1,0 P/ ENCAP. MOLA</p> | <p><b>216.1035</b></p>  <p>MANGUEIRA LONADA 3,5 MM</p>       | <p><b>216.1050</b></p>  <p>MANGUEIRA LONADA 5,0 MM</p>  | <p><b>216.1070</b></p>  <p>MANGUEIRA LONADA 7,0 MM</p>    |
| <p><b>216.1090</b></p>  <p>MANGUEIRA LONADA 9,0 MM</p>                  | <p><b>216.1100</b></p>  <p>MANGUEIRA DE HIDROVACUO 12 MM</p> | <p><b>216.1120</b></p>  <p>MANGUEIRA LONADA 12,0 MM</p> | <p><b>216.2035</b></p>  <p>MANGUEIRA DE INJEÇÃO 3,5MM</p> |



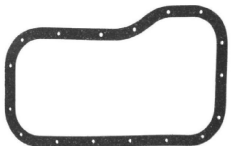



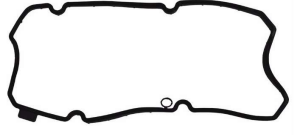

**450 MANGUEIRAS DIVERSAS**

|  |  |   |  |
|--|--|---|--|
| <p><b>216.2050</b></p>  <p>MANGUEIRA DE INJEÇÃO 5,0MM</p> | <p><b>216.2070</b></p>  <p>MANGUEIRA DE INJEÇÃO 7,0MM</p> | <p><b>216.2090</b></p>  <p>MANGUEIRA DE INJECAO 9,0MM</p> | <p><b>216.3050</b></p>  <p>MANGUEIRA COMBUSTIVEL CRISTAL 5,0 MM</p> |
|--|--|---|--|

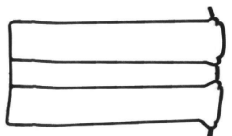
**455 JTA TAMPA VALV/CARTER - FIAT (BOR.)**

|   |  |  |   |
|---|--|--|---|
| <p><b>800200/1</b></p>   <p>JTAS.TP VALV FIRE 1.0 8V</p>                  | <p><b>800201/1</b></p>   <p>JTAS.TP VALV TIPO/TEMPRA16V</p>                          | <p><b>800202/1</b></p>   <p>JTAS.TP VALV TIPO/TEMPRA 8V</p>     | <p><b>800203/1</b></p>   <p>JTAS.TP VALV MAREA 20V</p>                  |
| <p><b>800204/1</b></p>   <p>JTAS.TP VALV DUCATO2.8 INJ.INDIR.</p>        | <p><b>800205/1</b></p>   <p>JTAS.TP VALV DUCATO 2.8 INJ.DIRE./DUCATO 2.5 TODOS-</p> | <p><b>800206/1</b></p>   <p>JTA CARTER FIRE 8V</p>             | <p><b>800207/1</b></p>   <p>JTA CARTER FIAT 147/ELBA/PREM. 1.0/1.3</p> |
| <p><b>800208/1</b></p>   <p>JTA CARTER FIASA C/ ILHÓS 1.0/1.3/1.5</p> | <p><b>800209/1</b></p>   <p>JTA CARTER DUCATO LADO ESQ.</p>                      | <p><b>800210/1</b></p>   <p>JTA CARTER DUCATO LADO DIR.</p> | <p><b>800214/1</b></p>  <p>JTATP VALV UNO EVO</p>  |

**460 JTA TAMPA VALV/CARTER - FORD (BORR.)**

|   |   |  |  |
|---|---|--|--|
| <p><b>800400/1</b></p>  <p>JTAS.TP VALV FIESTA/COURIER 1.4 16V</p> | <p><b>800401/1</b></p>  <p>JTAS.TP VALV ZETEC 1.8/2.0 16V</p>                  | <p><b>800402/1</b></p>  <p>JTAS.TP VALV. ZETEC ROCAN 1.4/1.6</p> | <p><b>800403/1</b></p>  <p>JTAS.TP VALV ZETEC 1.6/1.8/2.0 16V</p> |
| <p><b>800404/1</b></p>  <p>JTAS.TP VALV MOTOR CHT</p>              | <p><b>800404/K</b></p>  <p>KIT TP VALV CORCEL I/SED/GT 1.4 (COM VEDADORES)</p> |  |  |

**465 JTA TAMPA VALV/CARTER - GM (BORR.)**

**465 JTA TAMPA VALV/CARTER - GM (BORR.)**

|   |  |  |  |
|---|--|--|--|
| <p><b>800100/1</b></p> <p>JTAS.TP VALV CORSA 1.0/1.4/1.6 8V</p>     | <p><b>800101/1</b></p> <p>JTAS.TP VALV CORSA 8 V. 99/...</p>   | <p><b>800102/1</b></p> <p>JTAS.TP VALV CORSA 1.0/1.6 LADO DIR. E ESQ.-</p> | <p><b>800103/1</b></p> <p>JTAS.TP VALV MONZA/VECT...96 C/ILHÓS</p> |
| <p><b>800104/1</b></p> <p>JTAS.TP VALV VECTRA 8V.97/...</p>         | <p><b>800105/1</b></p> <p>JTAS.TP VALV VECTRA 16V</p>          | <p><b>800106/1</b></p> <p>JTA CARTER CORSA 1.0/1.6 16V</p>                 | <p><b>800107/1</b></p> <p>JTA CARTER MONZA</p>                     |
| <p><b>800109/1</b></p> <p>JTA TP VALV TRAFFIC MOTOR AIR ALC/GAS</p> | <p><b>800110/1</b></p> <p>JTA TP VALV S10 MOTOR MAXION 2.5</p> |  |  |

**470 JTA TAMPA VALV/CARTER - VW (BORR.)**

|   |  |   |  |
|---|--|---|--|
| <p><b>800300/1</b></p> <p>JTAS.TP VALV CENTRAL MOTOR AT 1.0 16V</p>         | <p><b>800300/K</b></p> <p>JTAS.TP VALV KIT CENTRAL E INTER. MOTOR AT 1.0 16V</p>           | <p><b>800301/1</b></p> <p>JTAS.TP VALV MOTOR AT 1.0 - 8V</p>        | <p><b>800302/1</b></p> <p>JTAS.TP VALV MOTOR AT 1.0 16V</p>      |
| <p><b>800303/1</b></p> <p>JTAS.TP VALV TODA LINHA 1.6/1.8/2.0 BORR. 8MM</p> | <p><b>800303/KB</b></p> <p>JTA VALV .(BORRACHA)TODA LINHA 1.6/1.8/2.0 8MM C/ VEDADORES</p> | <p><b>800304/1</b></p> <p>JTAS.TP VALV VW AP 1.6/1.8/2.0 97/...</p> | <p><b>800305/1</b></p> <p>JTA CARTER MOTOR AT (BORR.C/ILHÓS)</p> |
| <p><b>800306/1</b></p> <p>JTA CARTER MOTOR AP (BORR. C/ ILHÓS DE LATAO)</p> |  |   |  |

**475 JTA TAMPA VALV/CARTER - IMPORT. (BORR.)**

**475 JTA TAMPA VALV/CARTER - IMPORT. (BORR.)**

|   |   |  |  |
|---|---|--|--|
| <p><b>800500/1</b></p> <p>JTAS TP VALVULA TOPIC</p>           | <p><b>800501/1</b></p> <p>JTAS TP VALV TOWER</p>      | <p><b>800502/1</b></p> <p>JTAS TP VALV H-100</p> <p>2244142000</p> | <p><b>800503/1</b></p> <p>JTAS.TP VALV BESTA 2.7/GS</p>              |
| <p><b>800504/1</b></p> <p>JTAS TP VALV BESTA 2.7 GASOLINA</p> | <p><b>800505/1</b></p> <p>JTAS TP VALV.GRAN BESTA</p> | <p><b>800506/1</b></p> <p>JTAS TP CARTER TOWER</p>                 | <p><b>800507/1</b></p> <p>JTA TP VALV PEUGEOT 306 405 406 PATNER</p> |

**480 JTA TAMPA VALV/CARTER - FIAT (CORTIÇA)**

|   |  |   |  |
|---|--|---|--|
| <p><b>800207/C</b></p> <p>JTA CARTER FIAT 147/ELBA/PREM.1.0/1.3</p> | <p><b>800211/C</b></p> <p>JTA TP VALV F147/UNO/PREM./ELB/1050/1300</p> | <p><b>800212/C</b></p> <p>JTA TP VALV UNO/PREM./ELB/FIOR/1600 SEVEL</p> | <p><b>800213/C</b></p> <p>JTA CARTER PALIO/DOBLO 1.0/1.3 16V FIRE 99</p> |
|---|--|---|--|

**485 JTA TAMPA VALV/CARTER - FORD (CORTIÇA)**

|   |   |   |  |
|---|---|---|--|
| <p><b>800406/C</b></p> <p>JTAS.TP VALV KA/FIESTA/COUR/ ZETEC 1.4 16V 96..C/ILHOS CORT</p> | <p><b>800407/C</b></p> <p>JTA CARTER KA/FIESTA/COUR/ENDU.1.0 96/99(S/AR COND)</p> | <p><b>800408/C</b></p> <p>JTAS.TP VALV KA/FIESTA/COUR/ENDU.1.0 96/99(S/AR COND)</p> |  |
|---|---|---|--|

**490 JTA TAMPA VALV/CARTER - GM (CORTIÇA)**

|  |  |   |  |
|--|--|---|--|
| <p><b>800100/C</b></p> <p>JTA TP VALV CORSA 1.0/1.4/1.6 8V S/ILHOS</p> | <p><b>800103/C</b></p> <p>JTA TP VALV MZA/KADETT/IPAN.1.6/2.0 C/ILHOS</p>      | <p><b>800107/C</b></p> <p>JTA CARTER MONZA/KADETT/IPAN/1.6/2.0</p>    | <p><b>800108/C</b></p> <p>JTA TP VALV CORSA MOTOR 1.4 8V EFI C/ILHOS</p> |
| <p><b>800111/C</b></p> <p>JTA CARTER VECT 2.0/2.2/ASTRA 1.8/2.0 8V</p> | <p><b>800112/C</b></p> <p>JTA TAMPA DE VALVULA MONZA MOTOR 1.6/1.8 S/ILHOS</p> | <p><b>800113/C</b></p> <p>JTA TP VALV CHEV/MAR/CHEVY1.4/1.6 73/81</p> | <p><b>800113/K</b></p> <p>JTA TP VALV CHEV/MAR/CHEVY 1.4/1.6 73/81</p>   |

**490 JTA TAMPA VALV/CARTER - GM (CORTIÇA)**

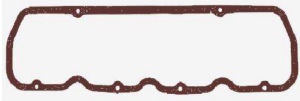
|  |  |  |  |
|--|--|--|--|
| <p><b>800114/C</b></p>  <p>JTA TP VALV OPALA/CARAV/COMOD.74</p> | <p><b>800115/C</b></p>  <p>JTA TP VALV OPA/CARAV/COMOD/C10 2500 4 CIL</p> |  |  |
|--|--|--|--|



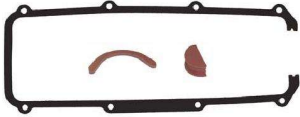
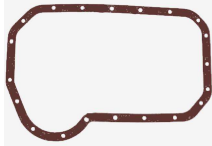
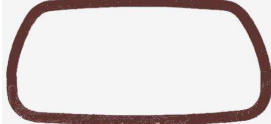

**495 JTA TAMPA VALV/CARTER - VW (CORTIÇA)**

|  |  |   |  |
|--|--|---|--|
| <p><b>800303/C</b></p>  <p>JTA TP VALV TODA LINHA 1.6/1.8/2.0 - 8MM</p> | <p><b>800303/K</b></p>  <p>JTA VALV .(CORTIÇA)TODA LINHA 1.6/1.8/2.0 8MM C/ VEDADORES</p> | <p><b>800307/C</b></p>  <p>JTA CARTER PASSAT/GOL/SANT.1.5/1.6/1.8</p> | <p><b>800308/C</b></p>  <p>JTA TP VALV VW/1200/1300/1500/1600</p> |
|--|--|---|--|





**500 COLETORES E ESCAPAMENTOS - ASIA MOTORS**

|   |  |  |  |
|---|--|--|--|
| <p><b>700501/1</b></p>  <p>JTA ADM. ASIA MOTORS TOWNER PHMR</p> | <p><b>700505/1</b></p>  <p>JTA SAÍDA ESCAPE TOWNER<br/>N.O.063.613.483</p> |  |  |
|---|--|--|--|

**505 COLETORES E ESCAPAMENTOS - AUDI**

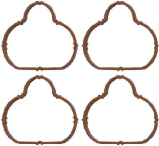
|  |   |   |   |
|--|---|---|---|
| <p><b>700506/1</b></p>  <p>JTA ADM AUDI A4 E A6 MOTOR 2.8 98/05<br/>N.O.078.129.717/A</p> | <p><b>700507/1</b></p>  <p>JTA ESCAPE AUDI A4 98/99/CORDOBA IBIZA 99<br/>N.O.037.253.039.D</p> | <p><b>700508/1</b></p>  <p>JTA ESCAPE AUDI A3</p> | <p><b>700509/1</b></p>  <p>JTA TURBINA AUDI A3 TURBO 20V. A6 20V. TT TURBO<br/>N.O.253115R</p> |
|--|---|---|---|

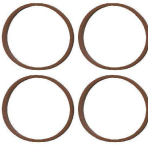
**510 COLETORES E ESCAPAMENTOS - CITROEN**

|   |  |  |   |
|---|--|--|---|
| <p><b>700601/1</b></p>  <p>JTAS ADM. CITROEN XSARA PICASSO GLX/EXCL.2.0 2001 / MPI</p> | <p><b>700602/1</b></p>  <p>JTAS ADM. CITROEN BERLINGO 1.8 8V(04 PÇS) SIL.</p> | <p><b>700603/1</b></p>  <p>JTAS ADM. CITROEN C3 1.6 16V(04 PÇS) SIL.</p> | <p><b>700604/1</b></p>  <p>JTAS ADM. CITROEN XSARA.8/16V (04 PÇS) SIL.</p> |
|---|--|--|---|

**515 COLETORES E ESCAPAMENTOS - FIAT**

|   |  |  |   |
|---|--|--|---|
| <p><b>700103/1</b></p>  <p>JTA ADM. ESCAPE FIAT1050/1300/1500 -85/..UNO MILLE MET.</p> | <p><b>700104/1</b></p>  <p>JTA ADM. FIAT TIPO 2.0 SLX 94/..16V PHMR</p> | <p><b>700105/1</b></p>  <p>JTA ADM. FIAT PALIO/SIENA 16V. METÁLICA</p> | <p><b>700106/1</b></p>  <p>JTA ESCAPE FIAT PALIO/SIENA 16V. METÁLICA</p> |
|---|--|--|---|



**515 COLETORES E ESCAPAMENTOS - FIAT**

|   |   |  |   |
|---|---|--|---|
| <p><b>700107/1</b></p> <p>JTA ADM ESCAPE PALIO 1.0-ED/EDX MPI 1.5 - 96/... MET.</p>                 | <p><b>700108/1</b></p> <p>JTA ESCAPE SAIDA FIAT PALIO 1.0/1.5-ED/EDX/MPI/ EL/SIENA/STRADA/UNO 96/..MET.</p> | <p><b>700109/1</b></p> <p>JTA ADMIS. FIAT TEMPRA 2.0 PHMR</p>  | <p><b>700110/1</b></p> <p>JTA ADMIS. FIAT PALIO 1.0-8V. PHMR</p>  |
| <p><b>700111/1</b></p> <p>JTA ESCAPE SAIDA PALIO/WEEKEND FIRE 8V METÁLICA</p>                       | <p><b>700112/1</b></p> <p>JTA ESCAPE SAIDA UNO/SIE/PALIO/WEEK/STR/BRAVA/16V FIRE</p>                        | <p><b>700113/1</b></p> <p>JTA ESCAPE FIAT FIRE 8V (02 PEÇAS) METÁLICA</p>                                | <p><b>700114/1</b></p> <p>JTA ADM. FIAT MAREA 20V PHMR</p>  |
| <p><b>700115/1</b></p> <p>JTA.ESCAPE FIAT UNO/SIENA/DOBLO/BRAVA FIRE 16V METÁLICA</p>               | <p><b>700116/1</b></p> <p>JTAS ADM. FIAT PALIO 1.6 16 V DOBLO ELX 1.6 (NBR)<br/>(04 PEÇAS)</p>              | <p><b>700117/1</b></p> <p>JTAS ADM. FIAT PALIO/WEEK/SIE/ELX/EX 1.0/1.3 16V (SILICONE)<br/>(04 PEÇAS)</p> | <p><b>700118/1</b></p> <p>JTAS ADM. FIAT PALIO/WEEK/SIE/ELX/EX 1.0/1.3 8V (SILICONE)<br/>(04 PEÇAS)</p> |
| <p><b>700119/1</b></p> <p>JTAS ADM. FIAT PALIO/SIENA 04/06 1.0 FIRE 8V(SILICONE)<br/>(04 PEÇAS)</p> | <p><b>700120/1</b></p> <p>JTA ADM. FIAT UNO MILE/ELX<br/>N.O.4.398.359</p>                                  | <p><b>700121/1</b></p> <p>JTA ADM. ESCAPE FIAT 1050/1300 - MILLE<br/>N.O.4.398.359</p>                   | <p><b>700122/1</b></p> <p>JTA ADM. ESCAPE FIAT 1500<br/>N.O. 4.195.133</p>                              |
| <p><b>700123/1</b></p> <p>JTA ADM. ESCAPE FIAT ELBA 1.6<br/>N.O.7.772.495</p>                       | <p><b>700125/1</b></p> <p>JTA ESCAPE FIAT TEMPRA 8 V/TIPO 2.0 16 V<br/>N.O.7.526.677</p>                    | <p><b>700126/1</b></p> <p>JTA ADM. ESCAPE FIAT TIPO 1.6 / UNO/ PREMIO / ELBA<br/>N.O.7.772.495</p>       | <p><b>700127/1</b></p> <p>JTA ADM. FIAT TIPO 2.0 SLX 94/... TEMPRA 2.0 8 V<br/>N.O.70.700.197</p>       |
| <p><b>700130/1</b></p> <p>JTA ESCAPE FIAT MAREA/BRAVA 1.8 16V<br/>N.O.73502761</p>                  | <p><b>700131/1</b></p> <p>JTA ESCAPE FIAT MAREA 2.0/2.4-BRAVA 2.0 20V TURBO<br/>N.O.46525557</p>            | <p><b>700132/1</b></p> <p>JTA ADM. FIAT MAREA/BRAVA/PUNTO STILO 1.8 16V.</p>                             | <p><b>700135/1</b></p> <p>JTA ESCAPE FIAT UNO/PREMIO 1.5/1.6 ARGENTINO</p>                              |

**515 COLETORES E ESCAPAMENTOS - FIAT**

|   |   |  |   |
|---|---|--|---|
| <p><b>700137/1</b></p> <p>JTA ESCAPE FIAT UNO BRIO 1.0 FURO OVAL</p>  | <p><b>700138/1</b></p> <p>JTA ESCAPE FIAT MAREA 1.8 2003</p> <p>N.O.46.772.217</p>              | <p><b>700139/1</b></p> <p>JTA ESCAPE FIAT BRAVA 1.6/MAREA 06/07-ALFA 145 98/99</p>               | <p><b>700140/1</b></p> <p>JTA ESCAPE FIAT SIENA/PALIO</p> |
| <p><b>700141/1</b></p> <p>JTA ESCAPE FIAT DOBLO/STILO</p>   | <p><b>700142/1</b></p> <p>JTA ESCAPE FIAT PALIO/SIENA/IDEA/STRADA/DOBLO/STILO 1.8 16V DOHC</p>  | <p><b>700143/1</b></p> <p>JTA CATALIZADOR FIAT TIPO 2.0 SLX ANO 94/...</p> <p>N.O.25.251.509</p> | <p><b>700144/1</b></p> <p>JTA CATALIZADOR LINHA FIAT</p>  |
| <p><b>700145/1</b></p> <p>JTA CATALIZADOR FIAT TEMPRA TURBO E 16 V. MAREA 2.0/2.4</p> <p>N.O.7.526.676 55181842</p> | <p><b>700146/1</b></p> <p>JTA CATALIZADOR FIAT PALIO EL/EDX/PALIO 1.6</p> <p>N.O.46.413.166</p> | <p><b>700147/1</b></p> <p>JTA ESCAPE FIAT FIORINO 1.3 FIRE/ IDEA 1.4 8V</p> <p>N.O.5519.7682</p> |   |







**520 COLETORES E ESCAPAMENTOS - FORD**

|   |  |  |  |
|---|--|--|--|
| <p><b>700129/1</b></p> <p>JTA ESCAPE FIAT PALIO/DOBLÓ 1.6 16V</p> <p>N.O.46.820.225</p> | <p><b>700203/1</b></p> <p>JTA CATALIZADOR FORD TODOS (METÁLICA)</p>              | <p><b>700204/1</b></p> <p>JTA ESCAPE FORD FIESTA (METÁLICA)</p>  | <p><b>700205/1</b></p> <p>JTAS ESCAPE FORD FIESTA ( METÁLICAS )</p> <p>(04 PEÇAS)</p>                        |
| <p><b>700206/1</b></p> <p>JTA ESCAPE FORD FIESTA-ENDURA-96/..(METÁLICA)</p>             | <p><b>700207/1</b></p> <p>JTA ESCAPE FORD KA ( ANEL METÁLICA )</p>               | <p><b>700208/1</b></p> <p>JTAS ADM. FORD ZETEC ROCAN 16V/KA 1.0/COUR.1.6( SILICONE )</p> <p>(02 PEÇAS)</p> | <p><b>700209/1</b></p> <p>JTAS ADM. FORD FIESTA/ECOSPORT 1.0L 8V (SILICONE)</p> <p>(02 PEÇAS)</p>            |
| <p><b>700210/0</b></p> <p>JTAS ADM. FORD RANGER 4.0L 94/95 PHMR</p> <p>(02 PEÇAS)</p>   | <p><b>700211/1</b></p> <p>JTA ESCAPE FORD ZETEC (METÁLICA)</p> <p>(02 PEÇAS)</p> | <p><b>700212/1</b></p> <p>JTAS ADM. FORD ZETEC 1.8/2.0 (SILICONE)</p> <p>(04 PEÇAS)</p>                    | <p><b>700213/1</b></p> <p>JTAS ADM. FORD FIESTA 1.4/COUR- 1.3/1.4 ZETEC 16V (SILICONE)</p> <p>(02 PEÇAS)</p> |

















**520 COLETORES E ESCAPAMENTOS - FORD**

|   |  |  |   |
|---|--|--|---|
| <p><b>700214/1</b></p> <p>JTAS ADM. FORD RANGER 2300 L 95/97/2500 L 98/ (SILICONE)</p> <p>(04 PEÇAS)</p>        | <p><b>700216/1</b></p> <p>JTAS ADM. FORD FOCUS 1.8/2.0 16V 2001/ESCORT 1.8 16V SW 97/99/MONDEO 2.0</p> <p>(04 PEÇAS)</p> | <p><b>700217/1</b></p> <p>JTAS ADM. FORD NEW FIESTA (SILICONE)</p> <p>(04 PEÇAS)</p>         | <p><b>700218/1</b></p> <p>JTAS ADM. FORD RANGER 95/2001</p>   |
| <p><b>700219/1</b></p> <p>JTA COLETOR FORD CORCEL II</p> <p>N.O.BD9M.9448.A</p>                                 | <p><b>700220/1</b></p> <p>JTA ADM. ESCAPE FORD ESCORT CHT</p> <p>N.O.94AV.9498.P</p>                                     | <p><b>700221/1</b></p> <p>JTA COLETOR FORD CORCEL II ÁLCOOL</p> <p>N.O.BOM.9448.A</p>        | <p><b>700222/1</b></p> <p>JTA ENTRADA COLETOR ESCAPE FORD CHT 1.3/1.6</p> <p>N.O.029.129.589.1</p>            |
| <p><b>700223/1</b></p> <p>JTA ESCAPE FORD KA 1.6 2001/... FIESTA/ESCORT ZETEC ROCAM</p> <p>N.O.XS6E/9448/BB</p> | <p><b>700224/1</b></p> <p>JTA ESCAPE FORD KA/FIESTA 1.0 ROCAM 99/...</p> <p>N.O.XS6E/9448/AC</p>                         | <p><b>700225/1</b></p> <p>JTA ESCAPE FORD FIESTA ASPIRADO 03/...</p> <p>N.O.2S6G/9448/CB</p> | <p><b>700226/1</b></p> <p>JTA ESCAPE FORD FIESTA/ECOSPORT 1.6 SUPER CHARGE 03/...</p> <p>N.O.2S6G/9448/AD</p> |
| <p><b>700227/1</b></p> <p>JTA ESCAPE FORD FIESTA SEDAN 2001</p> <p>N.O.YS6G/9448/EC</p>                         | <p><b>700228/1</b></p> <p>JTA ADM. FORD KA/FIESTA ENDURO 96/99</p> <p>N.O. XS6G/9441/AA</p>                              | <p><b>700229/1</b></p> <p>JTA ADM.ESCAPE FORD F-1.000 FALCON - ARGENTINO</p>                 | <p><b>700230/1</b></p> <p>JTA ADM. FORD ESCORT/FIESTA/FOCUS 1.8/2.0 16V.</p>                                  |
| <p><b>700231/1</b></p> <p>JTA ESCAPE FORD CORCEL II 1.4 / 1.6 ANO 78 / 83/...</p> <p>N.O.BOM.9451.A</p>         | <p><b>700232/1</b></p> <p>JTA ESCAPE FORD FIESTA / KA / 1.0 / 1.3</p>  | <p><b>700233/1</b></p> <p>JTA CANO INTERM. FORD FIESTA/ ESCORT MOTOR ZETEC</p>               | <p><b>700234/1</b></p> <p>JTA INTER.FORD FIESTA COURIER 1.4 / 16 V</p> <p>N.O.95 FB/9451/AA</p>               |
| <p><b>700235/1</b></p> <p>JTA INTERMEDIÁRIA FORD ESCORT 1.8 / 16 V.</p>   | <p><b>700236/1</b></p> <p>JTA ESCAPE FORD FIESTA 96</p>  | <p><b>700237/1</b></p> <p>JTA ESCAPE FORD ESCORT/FIESTA MOTOR ZETEC</p>                      | <p><b>700238/1</b></p> <p>JTA ESCAPE FORD RURAL WILLYS 6 CIL. ANO 1960 A 1975</p>                             |

**520 COLETORES E ESCAPAMENTOS - FORD**

|  |  |   |   |
|--|--|---|---|
| <p><b>700239/1</b></p>  <p>JTA INTERM. ESCAPE FORD<br/>MONDEO/FOCUS/FUSION<br/>FIESTA/ECOSPORT 2.0 16V. DURATEC</p> | <p><b>700240/1</b></p>  <p>JTA ESCAPE FORD KA/FIESTA/ECOSPORT<br/>ZETEC ROCAM/SUPERCHARGE 1.0/1.6 99/03</p> <p>N.O.XS 619451/DC</p> | <p><b>700241/1</b></p>  <p>JTA ESCAPE FORD FIESTA COURIER 1999</p> <p>N.O.N91AB 9451/MA</p> | <p><b>700242/1</b></p>  <p>JTA ESCAPE FORD F-1000 / F-4000</p> |
| <p><b>700243/1</b></p>  <p>JTA CATALISADOR VERTICAL FORD<br/>COURIER / FIESTA</p>                                   | <p><b>700244/1</b></p>  <p>JTA TURBINA FORD F-1000 (GRANDE)</p> <p>N.O.7.526.677</p>  | <p><b>700245/1</b></p>  <p>JTA DA BASE TURBINA FORD<br/>F-1.000/RANGER/GM S-10</p>          |   |

**525 COLETORES E ESCAPAMENTOS - GM**

|   |  |   |  |
|---|--|---|--|
| <p><b>700300/1</b></p>  <p>JTA ESCAPE GM<br/>MONZA/KADET/VECT/OME/IPAN. (METALICA)</p>      | <p><b>700302/1</b></p>  <p>JTA ESCAPE GM<br/>MONZA/KADET/OME/S-10/1.6/1.8/2.0<br/>(METALICA)</p> | <p><b>700303/1</b></p>  <p>JTA ADM. GM MONZA/KADET 1.6/1.8 (PHMR)</p>                        | <p><b>700304/1</b></p>  <p>JTA ESCAPE GM ANTI<br/>RUIDO-MZA/KADET/IPANE-(CHAP. DE UM<br/>LADO)</p>   |
| <p><b>700305/1</b></p>  <p>JTA ESCAPE GM ANTI<br/>RUIDO-MZA/KADET/IPAN-(CHAP.02 LADOS)</p> | <p><b>700307/1</b></p>  <p>JTA ADM. GM MONZA 2.0 87/...(PHMR)</p>                               | <p><b>700308/1</b></p>  <p>JTA ADM. GM CORSA 1.0 ( PHMR )</p>                               | <p><b>700309/1</b></p>  <p>JTA ESCAPE GM CORSA 1.0/1.4/1.6-8V.94/...( METÁLICA )</p>                |
| <p><b>700310/1</b></p>  <p>JTA ADM. GM CORSA 1.4/1.6 ( PHMR )</p>                          | <p><b>700311/1</b></p>  <p>JTA ESCAPE GM VECTRA/ASTRA2.0/2.2 16V<br/>97/02 (METÁLICA)</p>       | <p><b>700312/1</b></p>  <p>JTA ESCAPE GM VECTRA/ASTRA2.0/2.2 16V<br/>2003/...(METÁLICA)</p> | <p><b>700313/1</b></p>  <p>JTA ADM. GM CORSA 1.6 99/... GSI 16V ( PHMR )</p>                        |
| <p><b>700314/1</b></p>  <p>JTA ADM. GM OMEGA 4 CIL.2.0/MONZA<br/>CLAS.MPI (PHMR)</p>       | <p><b>700315/1</b></p>  <p>JTA ADM. GM VECTRA 1.8/2.0 16V ( PHMR )</p>                          | <p><b>700316/1</b></p>  <p>JTA ADM. GM CORSA 1.6 16V 1995/...( PHMR )</p>                   | <p><b>700317/1</b></p>  <p>JTAS ADM. GM CORSA/MERIVA/MONTANA<br/>2006/ 1.8 8V FLEX ( SILICONE )</p> |



**525 COLETORES E ESCAPAMENTOS - GM**

|   |   |  |   |
|---|---|--|---|
| <p><b>700318/1</b></p>  <p>JTA COLETOR GM OPALA 73 MOTOR 151 4 CC<br/>N.O.9.298.047</p>                                      | <p><b>700319/1</b></p>  <p>JTA ADM. CHEVETTE 1.4/1.6<br/>N.O.8.966.825</p>                         | <p><b>700320/1</b></p>  <p>JTA COLETOR GM OPALA 68/ 3 MOTOR 153 4CC / C-10/C-60<br/>N.O.3.731.062</p>  | <p><b>700321/1</b></p>  <p>JTA COLETOR ESCAPE GM CHEVETTE 1.4/1.6<br/>N.O.8.966.704</p>                            |
| <p><b>700322/1</b></p>  <p>JTA ADM. GM OPALA 4/6CC/A-10/A-20/A-40-70/C-10/C-20/C-60<br/>N.O. 3.788.485</p>                   | <p><b>700323/1</b></p>  <p>JTA COLETOR GM OPALA 6 CC<br/>N.O.3.953.746</p>                         | <p><b>700324/1</b></p>  <p>JTA COLETOR GM OPALA 6 CC<br/>N.O.3.826.261</p>                             | <p><b>700325/1</b></p>  <p>JTA ADM. GM VECTRA/ASTRA/MONZA</p>  |
| <p><b>700326/1</b></p>  <p>JTA ADM. INFERIOR GM TIGRA/CORSA GSI 16 V<br/>N.O.90.502.462</p>                                  | <p><b>700327/1</b></p>  <p>JTA COLETOR TUBO INTERMEDIARIO GM S-10 TURBO 2.5<br/>N.O.93.235.798</p> | <p><b>700328/1</b></p>  <p>JTA ESCAPE GM TRAFIC GASOLINA<br/>N.O.03533</p>                             | <p><b>700329/1</b></p>  <p>JTA ADM.ESCAPE GM MERIVA 1.8 MOTOR 8/16 V. S-10/BLAZER 2.5 DIESEL<br/>N.O.MI 704308</p> |
| <p><b>700330/1</b></p>  <p>JTA ADM. S-10/BLAZER 2.5 DIESEL<br/>N.O.MSB 85304/8</p>   | <p><b>700331/1</b></p>  <p>JTA ESCAPE S-10/ BLAZER/SILVERADO MOTOR MWM</p>                       | <p><b>700332/1</b></p>  <p>JTA ESCAPE BLAZER 4.3 V6</p>  | <p><b>700333/1</b></p>  <p>JTA ADM.ESCAPE GM OMEGA 3.0 93/98<br/>N.O.90409357</p>                                |
| <p><b>700334/1</b></p>  <p>JTA ADM.GM MERIVA 1.8 GAS 16V 2003/2005</p>   | <p><b>700335/1</b></p>  <p>JTA ADM/ESCAPE OMEGA 4.1</p>  | <p><b>700336/1</b></p>  <p>ANEL ANTI RUIDO VECTRA/ASTRA/OMEGA 3.0/CALIBRA 16V<br/>N.O.90.500.601</p> | <p><b>700337/1</b></p>  <p>JTA ESCAPE GM CHEV.HATCH/MARAJÓ/CHEVY 500<br/>N.O.9.308.295</p>                       |
| <p><b>700339/1</b></p>  <p>JTA TUBO INTER. S-10/BLAZER 2.2 / 2.5 DIESEL TURBO/S-10 CABINE SUPER 2.2<br/>N.O.93.228.370</p> | <p><b>700340/1</b></p>  <p>JTA ESCAPE S-10/BLAZER 4.3 MOTOR V 6<br/>N.O.15.997.161</p>           | <p><b>700341/1</b></p>  <p>JTA ESCAPE GM CORSA/TIGRA 1.6 16V/MERIVA 1.4/1.8<br/>N.O.90231452</p>     | <p><b>700342/1</b></p>  <p>JTA ESCAPE BLAZER/S-10 DIESEL</p>   |

**525 COLETORES E ESCAPAMENTOS - GM**

|   |  |  |   |
|---|--|--|---|
| <p><b>700343/1</b></p>  <p>JTA TURBINA PEQUENA D-20 / F-1000 TURBO</p> <p>N.O.90.231.063</p>                             | <p><b>700344/1</b></p>  <p>JTA ESCAPE PRIMÁRIO S-10 TURBO HSD</p> <p>N.O.93.214.342</p>                 | <p><b>700345/1</b></p>  <p>JTA ESCAPE GM TIGRA / CORSA GSI 16 V</p> <p>N.O. 93.470.036</p> | <p><b>700347/1</b></p>  <p>JTA CATALIZADOR LINHA CHEVROLET</p> <p>N.O.52.257.553</p> |
| <p><b>700348/1</b></p>  <p>JTA CATALIZADOR GM OMEGA 3.0 93/94/VECTRA 94/96/SUPR.2.0/2.2/CALIB.</p> <p>N.O.90.231.063</p> | <p><b>700349/1</b></p>  <p>JTA CATALIZADOR GM OMEGA 4.1 / 2.2 I ANO 95&lt;...</p> <p>N.O.93.214.342</p> | <p><b>700350/1</b></p>  <p>JTA CATALIZADOR BLAZER 4.3/2007</p>                             | <p><b>700504/1</b></p>  <p>JTA ADM. TOPIC</p> <p>N.O. K.706.131.11</p>               |

**530 COLETORES E ESCAPAMENTOS - HONDA**

|  |  |   |   |
|--|--|---|---|
| <p><b>700900/1</b></p>  <p>JTAS ADM. HONDA CIVIC 2005 (4 PÇS) SILICONE</p> | <p><b>700903/1</b></p>  <p>JTA ESCAPE HONDA CIVIC 16V. 87/02</p> <p>N.O.18.115.P.2.A.003</p> | <p><b>700904/1</b></p>  <p>JTA ESCAPE HONDA CIVIC 16V ANO 2001</p> | <p><b>700905/1</b></p>  <p>JTA ESCAPE HONDA</p> |
|--|--|---|---|

**535 COLETORES E ESCAPAMENTOS - HYUNDAI**



|   |   |  |  |
|---|---|--|--|
| <p><b>700511/1</b></p>  <p>JTA ESCAPE SECUN. HYUNDAI HR 2005/CAMINHÃO TUCSON 2.0 16V/2.7 V6/H100</p> <p>N.O.2876428020</p> | <p><b>700512/1</b></p>  <p>JTA ESCAPE PRIMÁRIA HYUNDAI HR 2005/CAMINHÃO</p> <p>N.O.287.764.4A000</p> | <p><b>700513/1</b></p>  <p>JTA ESCAPE ELANTRA/TUCSON 97/00</p> | <p><b>700514/1</b></p>  <p>JTA ESCAPE HYUNDAI HR 05/...</p> |
| <p><b>700515/1</b></p>  <p>JTA ADM. HYUNDAI HR 05/...</p>  | <p><b>700516/1</b></p>  <p>JTA ADM. ESCAPE HYUNDAI HR 05/...</p>                                     |  |  |

**540 COLETORES E ESCAPAMENTOS - JEEP**

|   |  |  |  |
|---|--|--|--|
| <p><b>700517/1</b></p>  <p>JTA ESCAPE JEEP GRAND CHEROKEE V8 16 VÁLVULAS 93/96</p> |  |  |  |
|---|--|--|--|

**545 COLETORES E ESCAPAMENTOS - KIA MOTORS**

**545 COLETORES E ESCAPAMENTOS - KIA MOTORS**

|  |   |  |  |
|--|---|--|--|
| <p><b>700502/2</b></p>  <p>JTA ADM. KIA MOTORS BESTA 2.7 PHMR</p> | <p><b>700503/3</b></p>  <p>JTA ADM. KIA MOTORS BESTA GS PHMR</p> |  |  |
|--|---|--|--|



**550 COLETORES E ESCAPAMENTOS - MERCEDES BENZ**

|  |  |  |  |
|--|--|--|--|
| <p><b>700346/1</b></p>  <p>JTA BASE DA TURBINA GM D-20/FORD F-1.000/MERCEDES-BENZ</p> |  |  |  |
|--|--|--|--|

**560 COLETORES E ESCAPAMENTOS - NISSAN**

|  |  |   |   |
|--|--|---|---|
| <p><b>700521/1</b></p>  <p>JTA ESCAPE NISSAN MÁXIMA/PATHFINDER 92/95<br/>N.O.14037.V5000</p> | <p><b>700522/1</b></p>  <p>JTA INTERMEDIARIA NISSAN PATHFINDER 92/95<br/>N.O.20692 / 31G02</p> | <p><b>700523/1</b></p>  <p>JTA INTERMEDIARIA NISSAN PATHFINDER 92/95<br/>20692/31G01-20692/31G80</p> | <p><b>700524/1</b></p>  <p>JTA ESCAPE NISSAN PATHFINDER 93/95<br/>N.O.20691/01E80</p> |
| <p><b>700525/1</b></p>  <p>JTA CATALIZADOR NISSAN PATHFINDER 92/95<br/>20692/01E810</p>     |  |   |   |

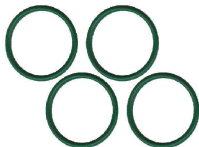
**565 COLETORES E ESCAPAMENTOS - PEUGEOT**

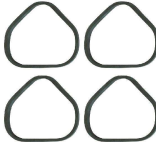
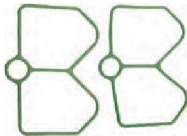
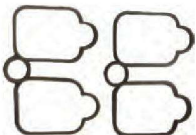
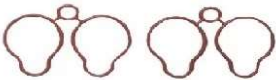















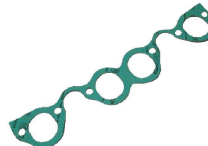

|  |   |  |  |
|--|---|--|--|
| <p><b>700801/1</b></p>  <p>JTAS ADM. PEUGEOT 206 1.6 8V MPI (04 PÇS) SILICONE</p>                   | <p><b>700802/1</b></p>  <p>JTAS ADM. PEUGEOT 206 1.6 16V MPI (04 PÇS) SIL.</p> | <p><b>700803/1</b></p>  <p>JTAS ADM. PEUGEOT 206 1.0 16V MPI (04 PÇS) SIL.</p> | <p><b>700804/1</b></p>  <p>JTAS ADM. PEUGEOT 306 93/...405/406 92/...406 97/... PATNER 97/...</p> |
| <p><b>700805/1</b></p>  <p>JTAS ADM. PEUGEOT 306 93/...405/406 92/...406 97/... PATNER 1997/...</p> | <p><b>700806/1</b></p>  <p>JTA ADM. PEUGEOT 306/405/XANTIA/XSARA 2.0</p>       |  |  |

**570 COLETORES E ESCAPAMENTOS - RENAULT**

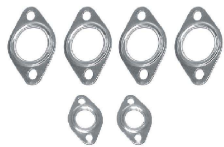
**570 COLETORES E ESCAPAMENTOS - RENAULT**





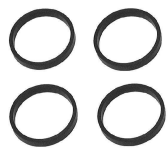
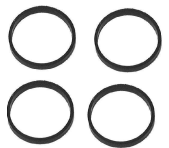







|  |  |   |  |
|--|--|---|--|
| <p><b>700701/1</b></p>  <p>JTAS ADM. RENAULT RN/RL/RT 1.0 CLIO HATCH 16V 2000 SIL</p> | <p><b>700702/1</b></p>  <p>JTAS ADM. RENAULT SEDAN CLIO 1.6/2000 16V SILIC.</p> | <p><b>700703/1</b></p>  <p>JTAS ADM. RENAULT CLIO HATCH RN/RL/RT 1.0 8V 2000 SILIC.</p> | <p><b>700704/1</b></p>  <p>JTAS ADM. RENAULT SCENIC 2.0 16V 2002/ SIL</p> |
|--|--|---|--|

**580 COLETORES E ESCAPAMENTOS - VW**

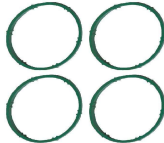
|   |   |  |  |
|---|---|--|--|
| <p><b>700400/1</b></p>  <p>JTA ADMIS. ANEL DO TUBO VW 1300 MET.</p>                            | <p><b>700401/1</b></p>  <p>JTA ADM. VW 1500/1600 (OCULOS) PHMR</p>                         | <p><b>700402/1</b></p>  <p>JTA ESCAPE VW AP 1.6/1.8/2.0 (METÁLICA)</p>               | <p><b>700403/1</b></p>  <p>JTA ESCAPE VW AP 1.6/1.8/2.0 (METÁLICA)</p>          |
| <p><b>700404/1</b></p>  <p>JTA ESCAPE TUBO ASPIR. 1200/1300-(PQ) METÁLICA</p>                 | <p><b>700405/1</b></p>  <p>JTA ADM. VW AP - VW/FORD/TODOS PHMR</p>                        | <p><b>700406/1</b></p>  <p>JTA ADM. VW AP VW/FORD 1.5/1.6 PHMR</p>                  | <p><b>700407/1</b></p>  <p>JTA ESCAPE SAIDA VW SANT.1.8/2.0-MODER.MET.</p>     |
| <p><b>700408/1</b></p>  <p>JTA ESCAPE SAIDA VW AP 1.5/1.6 (PASSAT LS)4 FUROS MET.</p>        | <p><b>700409/1</b></p>  <p>JTA ESCAPE SAIDA VW AP 1.6/1.8/2.0(PASSAT TS)6 FUROS MET.</p> | <p><b>700411/1</b></p>  <p>JTAS ESCAPE VW 1200/1300 (2 PÇS GRD+2 PÇS PEQ) MET.</p> | <p><b>700412/1</b></p>  <p>JTAS ESCAPE VW 1500/1600 (4 PÇS GRDS) METÁLICA</p> |
| <p><b>700413/1</b></p>  <p>JTAS ESCAPE VW 1200/1300/1500/1600 (4 PÇS GRD+2 PÇS PEQ) MET.</p> | <p><b>700414/1</b></p>  <p>JTAS ESCAPE SAIDA VW 1200/1300/1500/1600 (GRD) MET.</p>       | <p><b>700415/1</b></p>  <p>JTA ESCAPE SAIDA VW AT 1000-8V.METÁLICA</p>             | <p><b>700416/1</b></p>  <p>JTA ESCAPE SAIDA VW AT 16V.METÁLICA</p>            |
| <p><b>700417/1</b></p>  <p>JTA ESCAPE VW AT 1000-8 V- METÁLICA</p>                           | <p><b>700418/1</b></p>  <p>JTA ESCAPE VW GOL 1.0 AT 16V.-METÁLICA</p>                    | <p><b>700419/1</b></p>  <p>JTAS ADM.VW GOL1000/PARATI 8V. AT (4 PÇS) SIL.</p>      | <p><b>700420/1</b></p>  <p>JTAS ADM.VW GOL 1000/PARATI 16V. AT(4 PÇS)SIL</p>  |

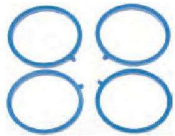

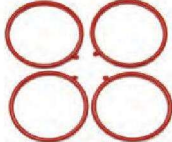
**580 COLETORES E ESCAPAMENTOS - VW**

|  |   |   |  |
|--|---|---|--|
| <p><b>700421/1</b></p>  <p>JTA ESCAPE SAÍDA VW GOL III/SAV/PAR. MET.</p>                      | <p><b>700422/1</b></p>  <p>JTA ESCAPE VW GOLF 1.6 METÁLICA</p>                       | <p><b>700423/1</b></p>  <p>JTA ADM. VW GOLF 2.0 2001</p> <p>N.O.06A29717</p>                      | <p><b>700424/1</b></p>  <p>JTA ESCAPE SAÍDA VW GOLF 1.6 (METÁLICA)</p> <p>N.O.533.253.115-C</p> |
| <p><b>700425/1</b></p>  <p>JTAS ADM. SUPERIOR VW GOLF 1.6 (04 PÇS) SIL.</p> <p>06A133227D</p> | <p><b>700425/6</b></p>  <p>JTAS ADM. SUPERIOR/INFERIOR VW GOLF 1.6 (08 PÇS) SIL.</p> | <p><b>700426/1</b></p>  <p>JTAS ADM. INFERIOR VW GOLF 1.6 (04 PÇS) SIL.</p> <p>N.O.06A133398F</p> | <p><b>700427/1</b></p>  <p>JTA ADM. VW GOLF GLM MÉXICO DE 96 A 98</p>                           |
| <p><b>700428/1</b></p>  <p>JTA ADM. VW PASSAT VARIANT 2000 DE 94 A 97</p>                     | <p><b>700429/1</b></p>  <p>JTAS ADM.VW FOX 1.0 8V ANO 2003/ MPI(4PÇS)</p>           | <p><b>700430/1</b></p>  <p>JTAS ADM.VW GOL GERAÇÃO IV 1.0 8V AT TOTAL FLEX 2006(4PÇS)</p>        | <p><b>700431/1</b></p>  <p>JTAS ADM. KOMBI 1.4 8V FLEX POWER 2007(4PÇS)</p>                    |
| <p><b>700432/1</b></p>  <p>JTA SAÍDA ESCAPE VW LOGUS/ESCORT 1.6 93/...</p>                  | <p><b>700433/1</b></p>  <p>JTA SAÍDA ESCAPE VW GOL/FOX POWER 8V</p>                |   |  |

**585 PEÇAS DIVERSAS MOTORES**



|  |   |  |  |
|--|---|--|--|
| <p><b>210022/A</b></p>  <p>ANEL ORING DA BOBINA FIRE 1.3/1.6</p>                  | <p><b>320301/1</b></p>  <p>JUNTA VALV.TERMOSTATICA FIESTA HATCH 1.6/KA 1.0 ZETEC ROCAM</p> | <p><b>320302/2</b></p>  <p>JUNTA VALV TERMOSTICA RENAULT CLIO/KANGOO/MEGANE/SCENIC TODOS 1.6 16V</p> | <p><b>320501/A</b></p>  <p>ANEL CONICO VALVULA DE COMANDO PALIO NBR</p> |
| <p><b>320503/B</b></p>  <p>BUCHA RESP. PASS./GOL/SAN/VERS.MOT.1.5/1.6/1.8/2.0</p> |   |  |  |

**590 JUNTAS P/ CAMBIO - FIAT**

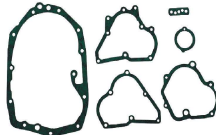

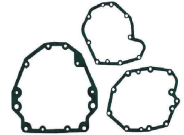

**590 JUNTAS P/ CAMBIO - FIAT**

|   |  |  |  |
|---|--|--|--|
| <p><b>450424/4</b></p>  <p>JTAS.CAMB. FIAT<br/>SPAZIO/PANORAMA/UNO/PREM./OGGI/ELBA<br/>4/5 M</p> |  |  |  |
|---|--|--|--|



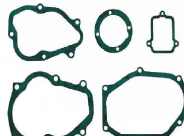

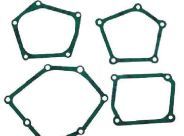
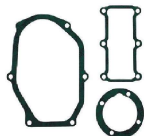
**595 JUNTAS P/ CAMBIO - FORD**

|   |  |  |  |
|---|--|--|--|
| <p><b>450411/1</b></p>  <p>JTAS.CAMB. CORCEL 68/78/CORCEL II<br/>79/...4/5 M</p> | <p><b>450413/3</b></p>  <p>JTAS.CAMB. ESCORT CHT 5 MARCHAS (S/<br/>ANEIS)</p> |  |  |
|---|--|--|--|

**600 JUNTAS P/ CAMBIO - GM**

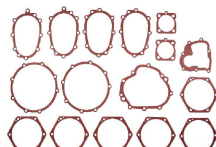

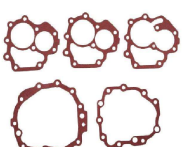
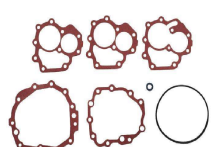
|   |  |   |   |
|---|--|---|---|
| <p><b>450401/1</b></p>  <p>JTAS.CAMB. CHEV.CLARK 1973/...4/5<br/>MARCHAS</p>          | <p><b>450403/3</b></p>  <p>JTAS.CAMB. MONZA 1.6/1.8/2.0 CAMB.<br/>CLARK 4 /5 MARCHAS</p> | <p><b>450404/4</b></p>  <p>JTAS.CAMB. OPALA 2500/3800/4100 SS<br/>CAMB.CLARK 4 M 68/78</p> | <p><b>450405/5</b></p>  <p>JTAS.CAMB. OPALA 90 HP/C10 CAMBIO<br/>CLARK 4/5 M 82/...</p> |
| <p><b>450406/6</b></p>  <p>JTAS.CAMB. CORSA 1.0/1.4/1.6<br/>WIND/GL/GSI 94/95...</p> |  |   |   |

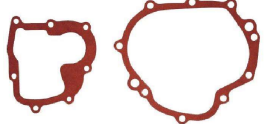
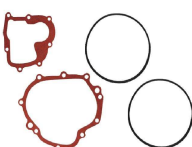
**605 JUNTAS P/ CAMBIO - VW**

|  |   |   |  |
|--|---|---|--|
| <p><b>450420/0</b></p>  <p>JTAS.CAMB. VW 1200/1300/1600 (S/ANEIS)</p> | <p><b>450420/A</b></p>  <p>JTAS.CAMB. VW 1200/1300/1600 (C/ ANEIS)</p> | <p><b>450421/1</b></p>  <p>JTAS.CAMB.<br/>PASSAT/GOL/VOY/PAR/SANT.1.5/1.6/1.8/2.0<br/>4/5 M (S/ANEIS)</p> | <p><b>450421/A</b></p>  <p>JTAS.CAMB.<br/>PASSAT/GOL/VOY/PAR/SANT.1.5/1.6/1.8/2.0<br/>4/5 M (C/ANEIS)</p> |
| <p><b>450421/B</b></p>  <p>JTAS.CAMB.PASSAT/GOL 4/5M 2 PÇS</p>        | <p><b>450422/2</b></p>  <p>JTAS.CAMB. KOMBI CLIPPER (S/ ANEIS)</p>     | <p><b>450422/A</b></p>  <p>JTAS.CAMB. KOMBI CLIPPER (C/ ANEIS)</p>  |  |

**610 JUNTAS DIVERSAS**











**610 JUNTAS DIVERSAS**

|   |  |  |  |
|---|--|--|--|
| <p><b>300406/A</b></p>  <p>JTA CAMBIO CORSA (PEQUENA) 1.0/1.4/1.6 WIND 94/95....</p> | <p><b>300406/B</b></p>  <p>JTA DIFERENCIAL CORSA 1.0/1.4/1.6 (PHMR 0.7MM)</p> | <p><b>300413/B</b></p>  <p>JTA AVULSA CAMBIO ESCORT CHT COM ILHOS DE COBRE</p> |  |
|---|--|--|--|

**615 PEÇAS PARA MOTOS**

|   |  |  |  |
|---|--|--|--|
| <p><b>210000</b></p>  <p>FILT. OLEO MOTO HONDA XR200/XLX 250R/XR 350</p> |  |  |  |
|---|--|--|--|

**620 TECIDOS E PAPEIS**

|   |   |  |   |
|---|---|--|---|
| <p><b>M-9900</b></p>  <p>PAPEL GUAMOTOR – AMARELO – 0,4MM (1M X 1M)</p>                   | <p><b>M-9901</b></p>  <p>PAPEL GUAMOTOR – AMARELO – 2,4MM (1M X 1M)</p>                   | <p><b>M-9902</b></p>  <p>PAPEL GUAMOTOR – VERDE – 0,4MM (1M X 1M)</p>                     | <p><b>M-9903</b></p>  <p>PAPEL GUAMOTOR – VERDE – 0,8MM (1M X 1M)</p>                     |
| <p><b>M-9906</b></p>  <p>PAPELÃO HIDRÁULICO SEM AMIANTO PHMR VERDE 0.7MM (2M X 1,5M)</p> | <p><b>M-9907</b></p>  <p>PAPELÃO HIDRÁULICO SEM AMIANTO PHMR VERDE 2.4MM (2M X 1,5M)</p> | <p><b>M-9908</b></p>  <p>PAPELÃO HIDRÁULICO SEM AMIANTO PHMR VERDE 0.4MM (2M X 1,5M)</p> | <p><b>M-9909</b></p>  <p>PAPELÃO HIDRÁULICO SEM AMIANTO PHMR VERDE 1.5MM (2M X 1,5M)</p> |
| <p><b>M-9915</b></p>  <p>TECIDO EMBORRACHADO PRETO 0,3MM (1M X 1M)</p>                   | <p><b>M-9916</b></p>  <p>TECIDO EMBORRACHADO VERMELHO 0,3MM (1M X 1M)</p>                | <p><b>M-9917</b></p>  <p>TECIDO EMBORRACHADO VERMELHO 0,8MM ALGODÃO (1M X 1M)</p>        |   |

# Índice Remissivo

| Cód           | Pg | Cód            | Pg | Cód           | Pg | Cód             | Pg | Cód          | Pg | Cód           | Pg | Cód             | Pg | Cód           | Pg | Cód               | Pg |                 |    |                   |    |
|---------------|----|----------------|----|---------------|----|-----------------|----|--------------|----|---------------|----|-----------------|----|---------------|----|-------------------|----|-----------------|----|-------------------|----|
| 100040/1..... | 2  | 130529.....    | 10 | 200040/0..... | 68 | 208.2013 P..... | 72 | 2112075..... | 75 | 225039/9..... | 59 | 300406/A.....   | 92 | 460252.....   | 14 | 500460/3.....     | 7  | 52.201/180..... | 50 | 52.451/160.....   | 48 |
| 100040/2..... | 1  | 130532.....    | 12 | 200041/1..... | 61 | 2082014.....    | 72 | 2112076..... | 75 | 225040/0..... | 67 | 300406/B.....   | 92 | 460260.....   | 16 | 500460/4.....     | 4  | 52.201/182..... | 50 | 52.451/162,5..... | 48 |
| 100040/3..... | 2  | 130533.....    | 12 | 200042/2..... | 68 | 2082015.....    | 70 | 2112077..... | 75 | 225041/1..... | 60 | 300413/B.....   | 92 | 460261.....   | 16 | 500460/5.....     | 4  | 52.201/185..... | 50 | 52.451/165.....   | 48 |
| 100040/4..... | 2  | 150175/1.....  | 3  | 200043/3..... | 66 | 2082016.....    | 70 | 2112078..... | 75 | 225042/2..... | 67 | 300405/B.....   | 4  | 460262.....   | 16 | 500460/6.....     | 9  | 52.201/187..... | 50 | 52.451/167,5..... | 48 |
| 100040/5..... | 2  | 150176/1.....  | 3  | 200044/4..... | 68 | 2082017.....    | 70 | 2112079..... | 76 | 225043/3..... | 65 | 300460/C.....   | 4  | 460263.....   | 16 | 500460/7.....     | 4  | 52.201/190..... | 50 | 52.451/170.....   | 48 |
| 100040/6..... | 1  | 150489/1.....  | 3  | 200045/5..... | 63 | 2082018.....    | 70 | 2112080..... | 76 | 225044/4..... | 67 | 300460/F.....   | 4  | 460264.....   | 16 | 500495/1.....     | 9  | 52.201/192..... | 50 | 52.451/172,5..... | 48 |
| 100050/1..... | 1  | 150495/1.....  | 3  | 200046/6..... | 68 | 2082019.....    | 70 | 2112081..... | 76 | 225045/5..... | 62 | 300460/W.....   | 4  | 460265.....   | 16 | 500495/2.....     | 4  | 52.201/195..... | 50 | 52.581/050.....   | 50 |
| 100050/2..... | 1  | 150495/2.....  | 3  | 200047/7..... | 63 | 2082022.....    | 70 | 2112082..... | 76 | 225046/6..... | 67 | 303056.....     | 35 | 460266.....   | 16 | 500495/5.....     | 4  | 52.201/197..... | 50 | 52.581/055.....   | 50 |
| 100050/5..... | 1  | 150500/1.....  | 3  | 200048/8..... | 61 | 2082023.....    | 70 | 2112083..... | 76 | 225047/7..... | 62 | 303057.....     | 35 | 460270.....   | 15 | 52.101/080.....   | 45 | 52.201/200..... | 50 | 52.581/060.....   | 50 |
| 100050/7..... | 2  | 150501/1.....  | 4  | 200049/9..... | 61 | 2082024.....    | 70 | 2112084..... | 76 | 225048/8..... | 60 | 303078.....     | 35 | 460272.....   | 16 | 52.101/082.....   | 45 | 52.201/205..... | 50 | 52.581/065.....   | 50 |
| 100070/1..... | 1  | 160505.....    | 11 | 200050/0..... | 65 | 2082025.....    | 72 | 2112085..... | 76 | 225049/9..... | 69 | 303079.....     | 35 | 460306.....   | 14 | 52.101/085.....   | 45 | 52.201/210..... | 50 | 52.581/070.....   | 50 |
| 100070/2..... | 1  | 160506.....    | 11 | 200051/1..... | 66 | 208.2025-1..... | 72 | 2112086..... | 76 | 225050/0..... | 64 | 3031004.....    | 35 | 460318.....   | 14 | 52.101/087.....   | 45 | 52.201/215..... | 50 | 52.581/075.....   | 50 |
| 100111/1..... | 3  | 160522.....    | 10 | 200052/2..... | 66 | 2082026.....    | 72 | 2112087..... | 76 | 225051/1..... | 65 | 303101305.....  | 35 | 460349.....   | 14 | 52.101/090.....   | 45 | 52.201/220..... | 50 | 52.581/080.....   | 50 |
| 100112/1..... | 3  | 170510.....    | 12 | 200053/3..... | 68 | 208.2026-1..... | 72 | 2112088..... | 76 | 225052/2..... | 65 | 303.175/T.....  | 35 | 460350.....   | 14 | 52.101/095.....   | 45 | 52.251/080..... | 42 | 52.591/040.....   | 52 |
| 100112/2..... | 3  | 170521.....    | 12 | 200054/4..... | 61 | 2082027.....    | 73 | 2112089..... | 76 | 225053/3..... | 67 | 320.050/B.....  | 35 | 460352.....   | 14 | 52.101/097,5..... | 45 | 52.251/082..... | 42 | 52.591/042.....   | 52 |
| 100113/1..... | 1  | 170523.....    | 10 | 200055/5..... | 61 | 2082028.....    | 73 | 2112090..... | 76 | 225054/4..... | 60 | 320.130/B.....  | 35 | 460362.....   | 14 | 52.101/100.....   | 45 | 52.251/085..... | 42 | 52.591/045.....   | 52 |
| 100114/1..... | 3  | 170.534-1..... | 11 | 200056/6..... | 65 | 2082029.....    | 70 | 2112091..... | 76 | 225055/5..... | 61 | 320.175/A.....  | 35 | 460402.....   | 15 | 52.101/102.....   | 45 | 52.251/087..... | 42 | 52.591/047.....   | 52 |
| 100114/2..... | 3  | 170.534-2..... | 13 | 200057/7..... | 69 | 2082033.....    | 72 | 2112092..... | 76 | 225056/6..... | 64 | 320.228/B.....  | 35 | 460412.....   | 15 | 52.101/105.....   | 45 | 52.251/090..... | 42 | 52.591/050.....   | 52 |
| 100117/1..... | 3  | 170538.....    | 11 | 200058/8..... | 69 | 2082034.....    | 73 | 2112093..... | 76 | 225057/7..... | 69 | 320.450/B.....  | 35 | 495001.....   | 16 | 52.101/107,5..... | 45 | 52.251/092..... | 42 | 52.591/052.....   | 52 |
| 100118/1..... | 2  | 170540.....    | 11 | 200059/9..... | 61 | 2082035.....    | 73 | 2112094..... | 76 | 225058/8..... | 69 | 303079.....     | 35 | 495002.....   | 16 | 52.101/110.....   | 45 | 52.251/095..... | 42 | 52.591/055.....   | 52 |
| 100130/1..... | 2  | 170541.....    | 13 | 200060/0..... | 68 | 2082036.....    | 73 | 2112095..... | 76 | 225059/9..... | 61 | 320.460/B1..... | 35 | 495018.....   | 16 | 52.101/112,5..... | 45 | 52.251/097..... | 42 | 52.591/057.....   | 52 |
| 100130/2..... | 1  | 170549.....    | 13 | 200061/1..... | 63 | 2082037.....    | 73 | 2112096..... | 76 | 225060/0..... | 67 | 320.460/BS..... | 35 | 495021.....   | 16 | 52.101/115.....   | 45 | 52.251/100..... | 42 | 52.591/060.....   | 52 |
| 100130/3..... | 2  | 174522.....    | 11 | 200062/2..... | 63 | 2082038.....    | 73 | 2112099..... | 76 | 225061/1..... | 62 | 320.460/PA..... | 35 | 495025.....   | 16 | 52.101/117,5..... | 45 | 52.251/102..... | 42 | 52.591/062.....   | 52 |
| 100130/4..... | 1  | 174533.....    | 11 | 200063/3..... | 60 | 2082040.....    | 73 | 2115001..... | 76 | 225062/2..... | 62 | 320.489/C.....  | 35 | 495028.....   | 16 | 52.101/120.....   | 45 | 52.251/105..... | 42 | 52.591/065.....   | 52 |
| 100150/1..... | 3  | 174542.....    | 11 | 200064/4..... | 61 | 2082041.....    | 73 | 2115002..... | 76 | 225063/3..... | 59 | 320.495/B.....  | 35 | 495029.....   | 16 | 52.101/122,5..... | 45 | 52.251/107..... | 42 | 52.591/067.....   | 52 |
| 100150/2..... | 3  | 175509.....    | 13 | 200065/5..... | 64 | 2082042.....    | 73 | 2115003..... | 76 | 225064/4..... | 61 | 320.739/A.....  | 35 | 495042.....   | 16 | 52.101/125.....   | 45 | 52.251/110..... | 42 | 52.591/070.....   | 53 |
| 100160/1..... | 2  | 175525.....    | 13 | 200066/6..... | 64 | 2082043.....    | 72 | 2115010..... | 76 | 225065/5..... | 63 | 320001/3B.....  | 69 | 495201.....   | 14 | 52.101/127,5..... | 45 | 52.251/112..... | 42 | 52.591/072.....   | 53 |
| 100160/2..... | 1  | 175526.....    | 13 | 200067/7..... | 64 | 2082044.....    | 72 | 2115011..... | 76 | 225066/6..... | 63 | 320001/3D.....  | 69 | 495206.....   | 14 | 52.101/130.....   | 45 | 52.251/115..... | 42 | 52.591/075.....   | 53 |
| 100170/1..... | 1  | 175530.....    | 13 | 200068/8..... | 60 | 2082045.....    | 74 | 2115012..... | 77 | 225067/7..... | 63 | 320001/B.....   | 69 | 495209.....   | 14 | 52.101/132,5..... | 46 | 52.251/117..... | 42 | 52.591/077.....   | 53 |
| 100175/1..... | 3  | 175537.....    | 11 | 200069/9..... | 60 | 2082046.....    | 74 | 2115013..... | 77 | 225068/8..... | 59 | 320001/C.....   | 69 | 495210.....   | 14 | 52.101/135.....   | 46 | 52.251/120..... | 43 | 52.591/080.....   | 53 |
| 100175/2..... | 2  | 175554.....    | 13 | 200070/0..... | 60 | 2082047.....    | 74 | 2115014..... | 77 | 225069/9..... | 59 | 320001/E.....   | 69 | 495212.....   | 14 | 52.101/137,5..... | 46 | 52.251/122..... | 43 | 52.591/082.....   | 53 |
| 100175/3..... | 3  | 175557.....    | 13 | 200071/1..... | 60 | 2082048.....    | 72 | 2115015..... | 77 | 225070/0..... | 59 | 320002/F.....   | 69 | 495219.....   | 14 | 52.101/140.....   | 46 | 52.251/125..... | 43 | 52.591/085.....   | 53 |
| 100175/4..... | 2  | 175569.....    | 11 | 200072/2..... | 61 | 2082049.....    | 72 | 2115016..... | 77 | 225071/1..... | 59 | 320010/2.....   | 70 | 495400.....   | 16 | 52.101/142,5..... | 46 | 52.251/127..... | 43 | 52.591/090.....   | 53 |
| 100176/1..... | 3  | 175589.....    | 13 | 200073/3..... | 61 | 2082051.....    | 74 | 2115017..... | 77 | 225072/2..... | 61 | 320010/2A.....  | 70 | 495401.....   | 16 | 52.101/145.....   | 46 | 52.251/130..... | 43 | 52.631/040.....   | 51 |
| 100176/2..... | 2  | 175594.....    | 13 | 200074/4..... | 62 | 2082054.....    | 71 | 2115018..... | 77 | 225073/3..... | 61 | 320041/T.....   | 70 | 495402.....   | 16 | 52.101/147,5..... | 46 | 52.251/132..... | 43 | 52.631/042.....   | 51 |
| 100181/1..... | 2  | 175597.....    | 13 | 200075/5..... | 68 | 2082306.....    | 71 | 2115019..... | 77 | 225074/4..... | 61 | 320046/T.....   | 70 | 495403.....   | 17 | 52.101/150.....   | 46 | 52.251/135..... | 43 | 52.631/045.....   | 51 |
| 100186/1..... | 2  | 176502.....    | 13 | 200075/5..... | 68 | 208.2307-1..... | 72 | 2115020..... | 77 | 225075/5..... | 67 | 320047/T.....   | 70 | 50543.....    | 11 | 52.101/152,5..... | 46 | 52.251/137..... | 43 | 52.631/047.....   | 51 |
| 100190/1..... | 1  | 176515.....    | 13 | 200076/6..... | 66 | 2082308.....    | 71 | 2115021..... | 77 | 225076/6..... | 67 | 320068/AB.....  | 70 | 500040/1..... | 8  | 52.101/155.....   | 46 | 52.251/140..... | 43 | 52.631/050.....   | 51 |
| 100190/2..... | 2  | 176520.....    | 11 | 200077/7..... | 66 | 2082309.....    | 71 | 2115022..... | 77 | 225077/7..... | 65 | 320107/A.....   | 70 | 500040/2..... | 6  | 52.101/157,5..... | 46 | 52.251/142..... | 43 | 52.631/052.....   | 51 |
| 100190/3..... | 1  | 176534.....    | 13 | 200078/8..... | 66 | 208.2310-1..... | 72 | 2115023..... | 77 | 225078/8..... | 65 | 320121/A.....   | 70 | 500040/5..... | 8  | 52.101/160.....   | 46 | 52.251/145..... | 43 | 52.631/055.....   | 51 |
| 100190/4..... | 2  | 176542.....    | 13 | 200079/9..... | 66 | 2082312.....    | 71 | 2115024..... | 77 | 225079/9..... | 65 | 320121/D.....   | 70 | 500040/6..... | 6  | 52.101/162,5..... | 46 | 52.251/147..... | 43 | 52.631/057.....   | 51 |
| 100190/5..... | 1  | 176552.....    | 13 | 200080/0..... | 66 | 208.2312-1..... | 72 | 2115025..... | 77 | 225079/9..... | 66 | 320301/1.....   | 90 | 500050/1..... | 6  | 52.101/165.....   | 46 | 52.251/150..... | 43 | 52.631/060.....   | 51 |
| 100200/1..... | 3  | 176553.....    | 13 | 200081/1..... | 66 | 2082313.....    | 71 | 2115026..... | 77 | 225080/0..... | 66 | 320002/2.....   | 90 | 500050/2..... | 5  | 52.101/167,5..... | 46 | 52.251/152..... | 43 | 52.631/062.....   | 51 |
| 100228/1..... | 2  | 176560.....    | 11 | 200082/2..... | 68 | 2082314.....    | 71 | 2115027..... | 77 | 225081/1..... | 66 | 320501/A.....   | 90 | 500050/4..... | 5  | 52.101/170.....   | 46 | 52.251/155..... | 43 | 52.631/065.....   | 51 |
| 100228/2..... | 2  | 176561.....    | 11 | 200083/3..... | 58 | 2082316.....    | 71 | 2115028..... | 77 | 225082/2..... | 67 | 320503/F.....   | 90 | 500050/5..... | 5  | 52.101/172,5..... | 46 | 52.251/157..... | 43 | 52.631/067.....   | 51 |
| 100228/3..... | 2  | 190011.....    | 15 | 200084/4..... | 58 | 208.2316-1..... | 72 | 2115029..... | 77 | 225083/3..... | 57 | 3205.495/F..... | 35 | 500050/7..... | 6  | 52.101/175.....   | 46 | 52.251/160..... | 43 | 52.631/070.....   | 52 |
| 100228/4..... | 1  | 190003.....    | 15 | 200085/5..... | 58 | 2082317.....    | 71 | 2115030..... | 77 | 225084/4..... | 57 | 40505.....      | 13 | 500070/1..... | 4  | 52.101/177,5..... | 46 | 52.251/1        |    |                   |    |



| Cód          | Pg | Cód        | Pg | Cód      | Pg | Cód      | Pg | Cód      | Pg | Cód       | Pg | Cód        | Pg | Cód      | Pg | Cód        | Pg | Cód         | Pg |
|--------------|----|------------|----|----------|----|----------|----|----------|----|-----------|----|------------|----|----------|----|------------|----|-------------|----|
| 52691        | 54 | 52.851/115 | 41 | 690114/1 | 9  | 700206/1 | 83 | 700411/1 | 89 | 800213/C  | 80 | M-3068     | 27 | T-001    | 17 | T-1515     | 30 | T-2155/52   | 24 |
| 52693        | 54 | 52.851/120 | 41 | 690114/2 | 9  | 700207/1 | 83 | 700412/1 | 89 | 800214/1  | 80 | M-3068     | 28 | T-002    | 17 | T-1516     | 30 | T-2155/55   | 24 |
| 52694        | 54 | 52.851/125 | 41 | 690114/4 | 9  | 700208/1 | 83 | 700413/1 | 89 | 800300/1  | 79 | M-3086     | 27 | T-002D   | 17 | T-1517     | 30 | T-2155/60   | 24 |
| 52697        | 54 | 52.851/130 | 41 | 690114/5 | 9  | 700209/1 | 83 | 700414/1 | 89 | 800300/K  | 79 | M-3087     | 27 | T-003    | 17 | T-1518     | 30 | T-2155/65   | 24 |
| 52700        | 55 | 52.851/135 | 41 | 690118/1 | 7  | 700210/0 | 83 | 700415/1 | 89 | 800301/1  | 79 | M-3088     | 28 | T-004    | 17 | T-1519     | 30 | T-2155/70   | 24 |
| 52701        | 55 | 52.851/140 | 41 | 690130/3 | 7  | 700211/1 | 83 | 700416/1 | 89 | 800302/1  | 79 | M-32.178   | 25 | T-005    | 17 | T-1520     | 30 | T-2155/85   | 24 |
| 52702        | 55 | 52.851/145 | 41 | 690130/4 | 5  | 700212/1 | 83 | 700417/1 | 89 | 800303/1  | 79 | M-32.180   | 26 | T-006    | 17 | T-1521     | 30 | T-2201/40   | 24 |
| 52703        | 55 | 52.851/150 | 41 | 690160/1 | 7  | 700213/1 | 83 | 700418/1 | 89 | 800303/C  | 81 | M-32.181   | 26 | T-007    | 17 | T-1553     | 30 | T-2201/42,5 | 24 |
| 52704        | 55 | 52.851/155 | 41 | 690160/2 | 5  | 700214/1 | 84 | 700419/1 | 89 | 800303/K  | 81 | M-34.115   | 26 | T-008    | 17 | T-1554     | 30 | T-2201/45   | 24 |
| 52705        | 55 | 52.851/160 | 41 | 690160/3 | 7  | 700216/1 | 84 | 700420/1 | 89 | 800303/K8 | 79 | M-40.235   | 26 | T-008D   | 17 | T-1555     | 30 | T-2201/47,5 | 24 |
| 52706        | 55 | 52.851/165 | 41 | 690175/2 | 7  | 700217/1 | 84 | 700421/1 | 90 | 800304/1  | 79 | M-40.238   | 26 | T-009    | 17 | T-1563     | 30 | T-2201/50   | 24 |
| 52707        | 55 | 52.851/170 | 41 | 690175/4 | 9  | 700218/1 | 84 | 700422/1 | 90 | 800305/1  | 79 | M-401.054  | 26 | T-009D   | 17 | T-1564     | 30 | T-2201/52,5 | 24 |
| 52708        | 55 | 52.851/175 | 41 | 690176/1 | 9  | 700219/1 | 84 | 700423/1 | 90 | 800306/1  | 79 | M-401.057  | 26 | T-010    | 17 | T-1565     | 30 | T-2201/55   | 24 |
| 52709        | 55 | 52.851/180 | 41 | 690176/2 | 7  | 700220/1 | 84 | 700424/1 | 90 | 800307/C  | 81 | M-401.483  | 26 | T-010D   | 17 | T-1566     | 30 | T-2201/57,5 | 24 |
| 52.710/080   | 39 | 52.851/185 | 41 | 690182/1 | 7  | 700221/1 | 84 | 700425/1 | 90 | 800308/C  | 81 | M-401.653  | 26 | T-011    | 17 | T-1567     | 30 | T-2201/60   | 25 |
| 52.710/085   | 39 | 52.851/190 | 41 | 690186/1 | 7  | 700222/1 | 84 | 700425/6 | 90 | 800400/1  | 78 | M-402.113  | 26 | T-011D   | 17 | T-2101/40  | 21 | T-2201/62,5 | 25 |
| 52.710/090   | 39 | 52.851/195 | 41 | 690190/1 | 5  | 700223/1 | 84 | 700426/1 | 90 | 800401/1  | 78 | M-402.251  | 26 | T-012    | 17 | T-2101/45  | 21 | T-2201/65   | 25 |
| 52.710/095   | 39 | 52.851/200 | 41 | 690190/2 | 7  | 700224/1 | 84 | 700427/1 | 90 | 800402/1  | 78 | M-402.373  | 26 | T-012D   | 17 | T-2101/50  | 21 | T-2201/67,5 | 25 |
| 52.710/100   | 39 | 52.851/205 | 42 | 690200/1 | 9  | 700225/1 | 84 | 700428/1 | 90 | 800403/1  | 78 | M-402.511  | 26 | T-013    | 17 | T-2101/55  | 21 | T-2201/70   | 25 |
| 52.710/105   | 39 | 52.851/210 | 42 | 690228/1 | 7  | 700226/1 | 84 | 700429/1 | 90 | 800404/1  | 78 | M-402.989  | 26 | T-013D   | 17 | T-2101/60  | 21 | T-2201/72,5 | 25 |
| 52.710/110   | 39 | 52.851/215 | 42 | 690228/2 | 7  | 700227/1 | 84 | 700430/1 | 90 | 800404/K  | 78 | M-403.632  | 26 | T-014    | 18 | T-2101/70  | 21 | T-2201/75   | 25 |
| 52.710/115   | 39 | 52.851/220 | 42 | 690228/3 | 7  | 700228/1 | 84 | 700431/1 | 90 | 800406/C  | 80 | M-5083     | 28 | T-014D   | 18 | T-2101/75  | 21 | T-2201/77,5 | 25 |
| 52.710/120   | 40 | 52.851/225 | 42 | 690228/4 | 5  | 700229/1 | 84 | 700432/1 | 90 | 800407/C  | 80 | M-5084     | 28 | T-015    | 18 | T-2102/40  | 21 | T-2201/80   | 25 |
| 52.710/125   | 40 | 52.851/230 | 42 | 690228/5 | 5  | 700230/1 | 84 | 700433/1 | 90 | 800408/C  | 80 | M-5085     | 28 | T-015D   | 18 | T-2102/45  | 21 | T-2201/85   | 25 |
| 52.710/130   | 40 | 52.907     | 57 | 690422/1 | 7  | 700231/1 | 84 | 700501/1 | 81 | 800500/1  | 80 | M-5086     | 28 | T-016    | 18 | T-2102/50  | 21 | T-2201/90   | 25 |
| 52.710/135   | 40 | 52.907-MJ  | 57 | 690427/1 | 7  | 700232/1 | 84 | 700502/2 | 88 | 800501/1  | 80 | M-5087     | 28 | T-017    | 18 | T-2102/55  | 21 | T-2201/95   | 25 |
| 52.710/140   | 40 | 52.909     | 57 | 690446/2 | 7  | 700233/1 | 84 | 700503/3 | 88 | 800502/1  | 80 | M-5313/13  | 28 | T-018    | 18 | T-2102/60  | 21 | T-2501      | 25 |
| 52.710/145   | 40 | 52.911     | 57 | 690450/1 | 9  | 700234/1 | 84 | 700504/1 | 87 | 800503/1  | 80 | M-5313/47  | 28 | T-019    | 18 | T-2102/70  | 21 | T-4262      | 20 |
| 52.710/150   | 40 | 52.911-MJ  | 57 | 690450/2 | 7  | 700235/1 | 84 | 700505/1 | 81 | 800504/1  | 80 | M-5313/55  | 28 | T-020    | 18 | T-2103/100 | 21 | T-4263      | 20 |
| 52.710/155   | 40 | 52.917     | 57 | 690450/3 | 9  | 700236/1 | 84 | 700506/1 | 81 | 800505/1  | 80 | M-5313/65  | 28 | T-021    | 18 | T-2103/120 | 21 | T-4275      | 20 |
| 52.710/160   | 40 | 52.920/070 | 57 | 690460/0 | 9  | 700237/1 | 84 | 700507/1 | 81 | 800506/1  | 80 | M-5313/80  | 28 | T-022    | 18 | T-2103/50  | 21 | T-4360      | 20 |
| 52.710/165   | 40 | 52.920/100 | 57 | 690460/4 | 5  | 700238/1 | 84 | 700508/1 | 81 | 800507/1  | 80 | M-5356/125 | 28 | T-023    | 18 | T-2103/60  | 21 | T-4381      | 20 |
| 52.710/170   | 40 | 52.920/110 | 57 | 690460/2 | 5  | 700239/1 | 85 | 700509/1 | 81 | D-01      | 33 | M-5356/130 | 28 | T-024    | 18 | T-2103/80  | 21 | T-4393      | 20 |
| 52.710/175   | 40 | 52.920/115 | 57 | 690460/3 | 8  | 700240/1 | 85 | 700511/1 | 87 | D-02      | 33 | M-5356/135 | 28 | T-025    | 18 | T-2103/85  | 21 | T-4409      | 20 |
| 52.710/180   | 40 | 52.920/150 | 57 | 690460/4 | 5  | 700241/1 | 85 | 700512/1 | 87 | D-03      | 33 | M-5356/165 | 28 | T-026    | 18 | T-2104/40  | 21 | T-4470      | 20 |
| 52.710/185   | 40 | 53050      | 55 | 690460/5 | 5  | 700242/1 | 85 | 700513/1 | 87 | D-04      | 33 | M-5380     | 28 | T-027    | 18 | T-2104/50  | 21 | T-4546      | 20 |
| 52.710/190   | 40 | 53051      | 55 | 690460/6 | 5  | 700243/1 | 85 | 700514/1 | 87 | D-05      | 33 | M-5381     | 28 | T-027D   | 18 | T-2104/60  | 21 | T-4767      | 20 |
| 52.710/195   | 40 | 53052      | 55 | 690460/7 | 5  | 700244/1 | 85 | 700515/1 | 87 | D-06      | 33 | M-5382     | 28 | T-028    | 18 | T-2104/70  | 21 | T-4770      | 20 |
| 52.710/200   | 40 | 53053      | 55 | 690460/8 | 6  | 700245/1 | 85 | 700516/1 | 87 | D-07      | 33 | M-8001     | 31 | T-028D   | 18 | T-2105/100 | 21 | T-4802      | 20 |
| 52.710/205   | 40 | 53054      | 55 | 690460/9 | 5  | 700300/1 | 85 | 700517/1 | 87 | D-08      | 33 | M-8002     | 31 | T-029    | 18 | T-2105/50  | 22 | T-4854      | 20 |
| 52.710/210   | 40 | 53055      | 55 | 690495/1 | 9  | 700302/1 | 85 | 700521/1 | 88 | D-09      | 33 | M-8003     | 31 | T-029D   | 18 | T-2105/80  | 22 | T-4887      | 20 |
| 52.710/215   | 40 | 53057      | 55 | 690495/2 | 5  | 700303/1 | 85 | 700522/1 | 88 | D-10      | 33 | M-8004     | 31 | T-030    | 18 | T-2106/100 | 22 | T-5353      | 29 |
| 52.710/220   | 40 | 53058      | 55 | 690495/5 | 5  | 700304/1 | 85 | 700523/1 | 88 | D-11      | 33 | M-8005     | 31 | T-031    | 18 | T-2106/50  | 22 | T-5354      | 29 |
| 52.710/230   | 40 | 53059      | 55 | 690495/6 | 9  | 700305/1 | 85 | 700524/1 | 88 | D-12      | 33 | M-8006     | 31 | T-032    | 18 | T-2106/80  | 22 | T-5355      | 29 |
| 52.710/235   | 40 | 53060      | 55 | 690495/7 | 5  | 700307/1 | 85 | 700525/1 | 88 | D-13      | 34 | M-8007     | 31 | T-033    | 19 | T-2107/50  | 22 | T-5401      | 29 |
| 52.761/090   | 37 | 53062      | 55 | 695175/1 | 10 | 700308/1 | 85 | 700601/1 | 81 | D-14      | 34 | M-8008     | 31 | T-034    | 19 | T-2107/65  | 22 | T-5418      | 29 |
| 52.761/110   | 37 | 53063      | 55 | 695176/1 | 10 | 700309/1 | 85 | 700602/1 | 81 | D-15      | 34 | M-8009     | 31 | T-035    | 19 | T-2107/70  | 22 | T-5419      | 29 |
| 52.761/120   | 37 | 53064      | 56 | 695489/1 | 10 | 700310/1 | 85 | 700603/1 | 81 | D-16      | 34 | M-8010     | 31 | T-036    | 19 | T-2108/35  | 22 | T-5420      | 29 |
| 52.761/125   | 37 | 53066      | 56 | 695489/1 | 10 | 700311/1 | 85 | 700604/1 | 81 | D-17      | 34 | M-8011     | 31 | T-037    | 19 | T-2108/40  | 22 | T-5421      | 29 |
| 52.761/130   | 38 | 53067      | 56 | 695495/2 | 10 | 700312/1 | 85 | 700701/1 | 89 | D-18      | 34 | M-8012     | 31 | T-038    | 19 | T-2108/45  | 22 | T-5422      | 29 |
| 52.761/135   | 38 | 53100      | 56 | 695495/3 | 10 | 700313/1 | 85 | 700702/1 | 89 | D-19      | 34 | M-8014     | 31 | T-039    | 19 | T-2108/50  | 22 | T-5510      | 29 |
| 52.761/140   | 38 | 53101      | 56 | 695495/4 | 10 | 700314/1 | 85 | 700703/1 | 89 | D-20      | 34 | M-8015     | 31 | T-040    | 19 | T-2108/55  | 22 | T-5592      | 29 |
| 52.761/145   | 38 | 53102      | 56 | 70103    | 10 | 700315/1 | 85 | 700704/1 | 89 | D-21      | 34 | M-8016     | 31 | T-048    | 19 | T-2108/60  | 22 | T-5620      | 29 |
| 52.771/060   | 38 | 53103      | 56 | 70502    | 10 | 700316/1 | 85 | 700801/1 | 88 | D-22      | 34 | M-8017     | 31 | T-049    | 19 | T-2108/70  | 22 | T-5625      | 29 |
| 52.771/062,5 | 38 | 53104      | 56 | 700103/1 | 81 | 700317/1 | 85 | 700802/1 | 88 | D-23      | 34 | M-8019     | 31 | T-050    | 19 | T-2108/80  | 22 | T-958       | 36 |
| 52.771/065   | 38 | 53105      | 56 | 700104/1 | 81 | 700318/1 | 86 | 700803/1 | 88 | D-24      | 34 | M-8020     | 31 | T-051    | 19 | T-2109/35  | 22 | T-959       | 36 |
| 52.771/067,5 | 38 | 53106      | 56 | 700105/1 | 81 | 700319/1 | 86 | 700804/1 | 88 | D-25      | 34 | M-8034     | 31 | T-052-2E | 19 | T-2109/60  | 22 | T-960       | 36 |
| 52.771/070   | 38 | 53107      | 56 | 700106/1 | 81 | 700320/1 | 86 | 700805/1 | 88 | D-26      | 34 | M-8041     | 31 | T-052-3E | 19 | T-2109/70  | 22 | T-961       | 36 |
| 52.771/075   | 38 | 53108      | 56 | 700107/1 | 82 | 700321/1 | 86 | 700806/1 | 88 | D-27      | 34 | M-8047     | 31 | T-053    | 19 | T-2109/80  | 22 | T-962       | 36 |
| 52.771/080   | 38 | 53110      | 56 | 700108/1 | 82 | 700322/1 | 86 | 700900/1 | 87 | D-28      | 34 | M-8049     | 31 | T-054    | 19 | T-2115/40  | 22 | T-963       | 36 |
| 52.771/090   | 38 | 53112      | 56 | 700109/1 | 82 | 700323/1 | 86 | 700903/1 | 87 | ESP001    | 3  | M-8050     | 31 | T-056    | 19 | T-2115/50  | 22 | T-964       | 36 |
| 52.771/100   | 38 | 53113      | 56 | 700110/1 | 82 | 700324/1 | 86 | 700904/1 | 87 | M-11.026  | 25 | M-8101     | 31 | T-057    | 19 | T-2115/70  | 22 | T-965       | 36 |
| 52.771/105   | 38 | 53114      | 56 | 700111/1 | 82 | 700325/1 | 86 | 700905/1 | 87 | M-130.346 | 25 | M-8102     | 32 | T-058    |    |            |    |             |    |





Micromil Indústria  
e Comércio LTDA.

Para visualizar e baixar este catálogo acesse:

[www.micro1000.com.br](http://www.micro1000.com.br)

**Tel: (11) 2252 -3682/2252-3688**



**(11) 9-6450-0469**

**E-mail: [micro1000@micro1000.com.br](mailto:micro1000@micro1000.com.br)**

